

## Short-circuit protection on the L6201, L6202 and the L6203

By Giuseppe Scrocchi and Thomas Hopkins

With devices like the L6201, L6202 or L6203 driving external loads you can often have short-circuits.

A short-circuit can occur for many reasons: a short on the load, a mistake during the connection of the wires between the device and the load (i.e. L6203 driving a motor), an accidental short between the wires and so on.

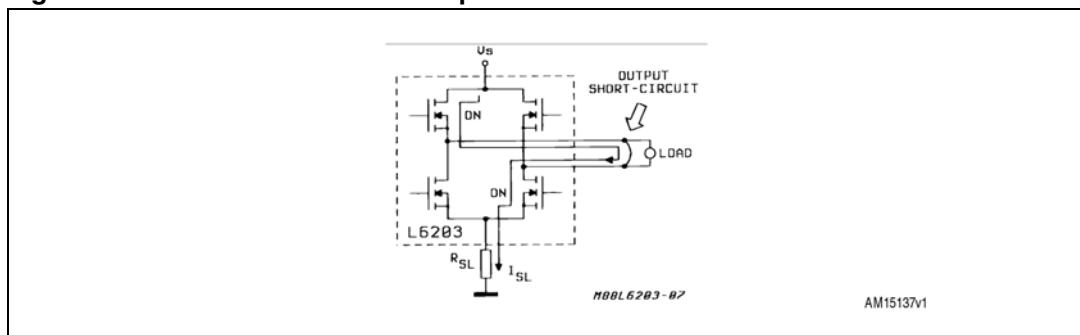
The outputs of these devices are not protected against the short-circuit and if a short occurs, the current flowing through the outputs can destroy the device.

To avoid this risk, additional a circuitry may be added to protect the device. To have a total protection, we must consider three types of short-circuit:

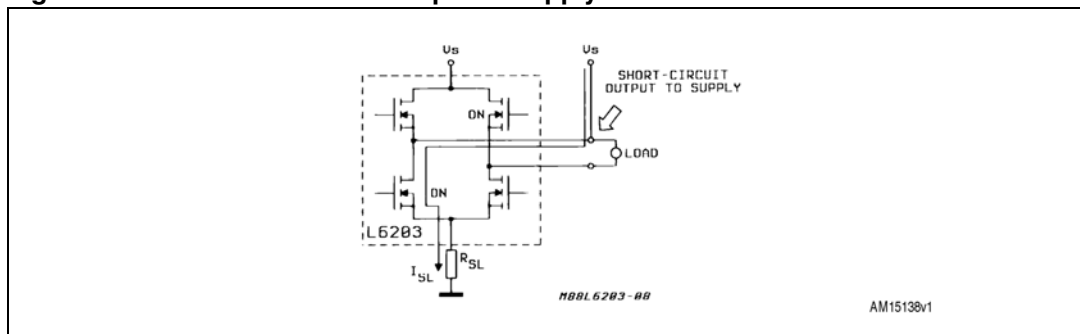
- output to output short-circuit
- output to supply voltage short-circuit
- output to ground short-circuit

The first step is to sense the short-circuit current. In output to output short-circuit (*Figure 1*) or output to supply (*Figure 2*) short-circuit, the sensing resistor ( $R_{SL}$ ) already used to set the current flowing in the load during the normal operation, may also be used for short-circuit sensing.

**Figure 1. Short-circuit across output**

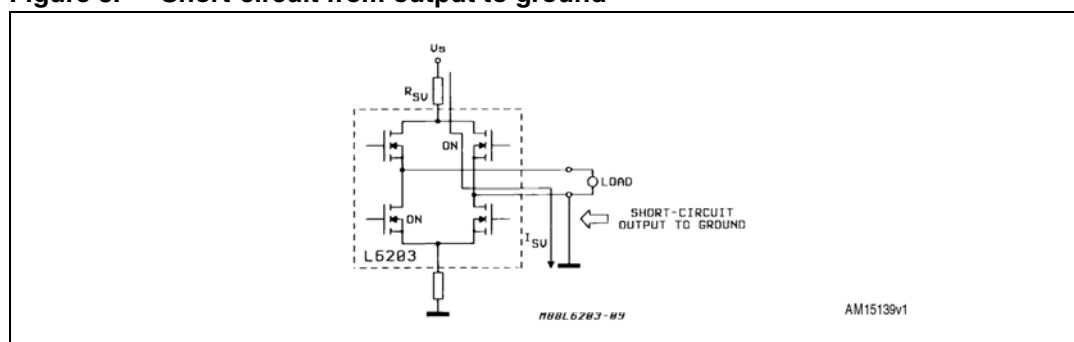


**Figure 2. Short-circuit from output to supply**



To sense the output to ground short-circuit, a sensing resistor ( $R_{SU}$ ) must be added between the supply pin and the supply voltage as shown in [Figure 3](#).

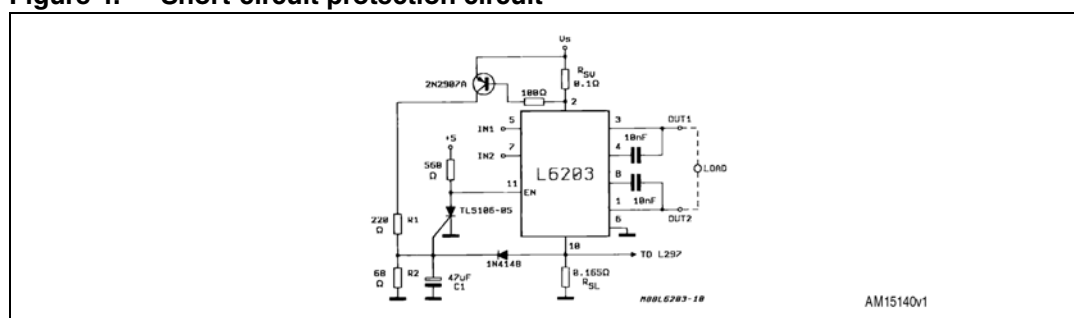
**Figure 3. Short-circuit from output to ground**



The second step is to set a threshold over which the value of the current to be considered as short-circuit. An easy threshold is to select the forward bias voltage of a diode or transistor. When the voltage across the sense resistor exceeds the  $V_f$  or  $V_{be}$ , the device turns on indicating an overcurrent from the short-circuit.

The overcurrent signal from both the upper and lower sense resistor are ORed together to trigger the shutdown to protect the device. One simple way to shutdown the device is to take the enable line low and latch it low. The circuit in [Figure 4](#) uses an SCR that will latch on and hold the enable low if an overcurrent occurs. The figures show the L6203, but the same configuration may be used with the L6201 or L6202.

**Figure 4. Short-circuit protection circuit**



In normal operation the circuit can work up to 3 A/40 V. When a short-circuit occurs the SCR is triggered and the L6203 is disabled. Due to the SCR memory, the L6203 is kept disabled until the power is switched off and back on, if the cause of short was removed.

The short-circuit is detected when:

**Equation 1**

$$I_{SU} > \frac{V_{BE(T1)}}{R_{SU}} = \frac{0.6}{0.1} = 6A$$

$$I_{SL} > \frac{V_D + V_{THSCMT}}{R_{SC}} = \frac{0.6 + 0.7}{0.165} = 7.8A$$

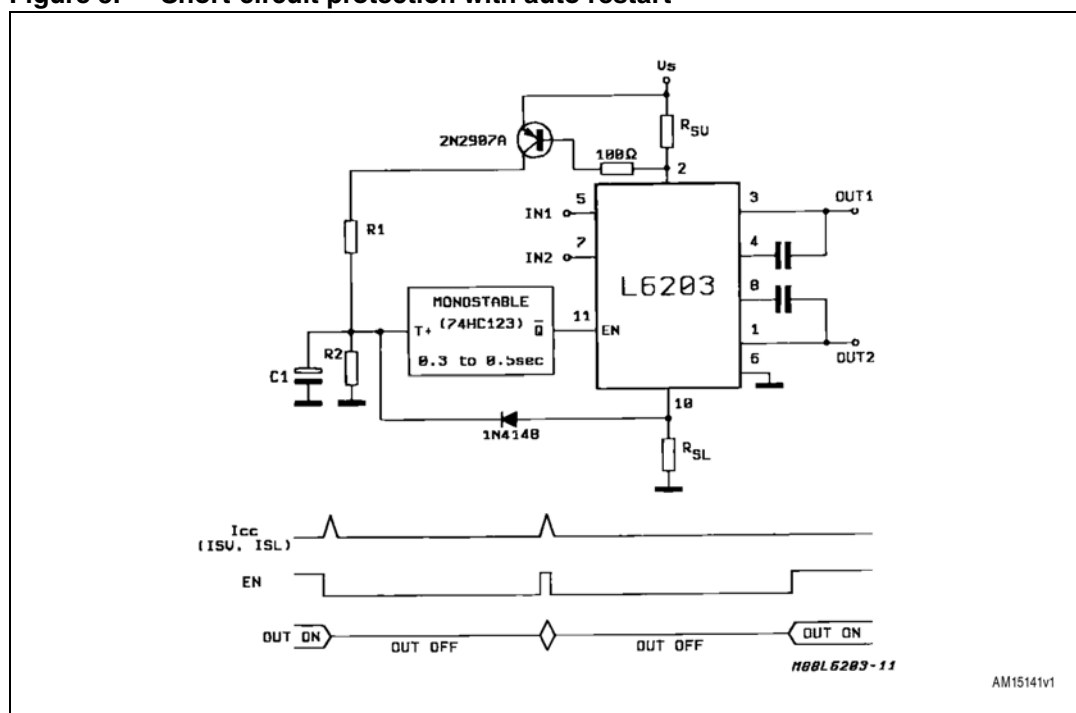
The effective short-circuit peak current is greater than  $I_{SU}$  and  $I_{SL}$ . This is due to the high  $di/dt$  during the short and to the delay between the short-circuit detection and the ENABLE intervention.  $R_{SU}$  and  $R_{SL}$  must be non inductive resistors.

$R1$  and  $R2$  are used to level shift the signal when the transistor turns on and in conjunction with  $C1$  to filter the short-circuit signals in order to avoid false trigger of the SCR. This filtering should not be heavy to avoid introducing an excessive delay in the short-circuit loop.

$I_{SU}$  and  $I_{SL}$  must be calculated at the effective operating temperature being the  $V_{be}$  and  $V_d$  temperature dependent.

Instead of the SCR, a monostable with a long time constant (0.3, 0.5 sec) can be used, as shown in *Figure 5*. In this case, every time a short-circuit occurs, the L6203 is disabled for the monostable time period and then enabled, if the short is still present the L6203 is disabled again, if the short was removed the L6203 returns in normal operation.

**Figure 5. Short-circuit protection with auto restart**



$R_1$ ,  $R_2$ ,  $C_1$ ,  $R_{SU}$ ,  $R_{SL}$  are chosen depending on the application.

The intervention of the protection circuit is determined by:

**Equation 2**

$$I_{SU} > \frac{V_{BE}}{R_{SU}} \quad I_{SL} > \frac{V_{IH} + V_D}{R_{SL}}$$

where:

$V_D = V_{DIODE}$ ;  $V_{IH} = \min V_{Input High T+Monostab.}$

# 1 Revision history

**Table 1. Document revision history**

Date	Revision	Changes
21-Apr-2008	1	Initial release.
24-Sep-2012	2	Added part numbers L6201 and L6202. Text updates throughout the document.

**Please Read Carefully:**

Information in this document is provided solely in connection with ST products. STMicroelectronics NV and its subsidiaries ("ST") reserve the right to make changes, corrections, modifications or improvements, to this document, and the products and services described herein at any time, without notice.

All ST products are sold pursuant to ST's terms and conditions of sale.

Purchasers are solely responsible for the choice, selection and use of the ST products and services described herein, and ST assumes no liability whatsoever relating to the choice, selection or use of the ST products and services described herein.

No license, express or implied, by estoppel or otherwise, to any intellectual property rights is granted under this document. If any part of this document refers to any third party products or services it shall not be deemed a license grant by ST for the use of such third party products or services, or any intellectual property contained therein or considered as a warranty covering the use in any manner whatsoever of such third party products or services or any intellectual property contained therein.

**UNLESS OTHERWISE SET FORTH IN ST'S TERMS AND CONDITIONS OF SALE ST DISCLAIMS ANY EXPRESS OR IMPLIED WARRANTY WITH RESPECT TO THE USE AND/OR SALE OF ST PRODUCTS INCLUDING WITHOUT LIMITATION IMPLIED WARRANTIES OF MERCHANTABILITY, FITNESS FOR A PARTICULAR PURPOSE (AND THEIR EQUIVALENTS UNDER THE LAWS OF ANY JURISDICTION), OR INFRINGEMENT OF ANY PATENT, COPYRIGHT OR OTHER INTELLECTUAL PROPERTY RIGHT.**

**UNLESS EXPRESSLY APPROVED IN WRITING BY TWO AUTHORIZED ST REPRESENTATIVES, ST PRODUCTS ARE NOT RECOMMENDED, AUTHORIZED OR WARRANTED FOR USE IN MILITARY, AIR CRAFT, SPACE, LIFE SAVING, OR LIFE SUSTAINING APPLICATIONS, NOR IN PRODUCTS OR SYSTEMS WHERE FAILURE OR MALFUNCTION MAY RESULT IN PERSONAL INJURY, DEATH, OR SEVERE PROPERTY OR ENVIRONMENTAL DAMAGE. ST PRODUCTS WHICH ARE NOT SPECIFIED AS "AUTOMOTIVE GRADE" MAY ONLY BE USED IN AUTOMOTIVE APPLICATIONS AT USER'S OWN RISK.**

Resale of ST products with provisions different from the statements and/or technical features set forth in this document shall immediately void any warranty granted by ST for the ST product or service described herein and shall not create or extend in any manner whatsoever, any liability of ST.

ST and the ST logo are trademarks or registered trademarks of ST in various countries.

Information in this document supersedes and replaces all information previously supplied.

The ST logo is a registered trademark of STMicroelectronics. All other names are the property of their respective owners.

© 2012 STMicroelectronics - All rights reserved

STMicroelectronics group of companies

Australia - Belgium - Brazil - Canada - China - Czech Republic - Finland - France - Germany - Hong Kong - India - Israel - Italy - Japan - Malaysia - Malta - Morocco - Philippines - Singapore - Spain - Sweden - Switzerland - United Kingdom - United States of America

[www.st.com](http://www.st.com)

