

STEVAL-IPP003V1

Schematic diagram

Figure 1. Power supply

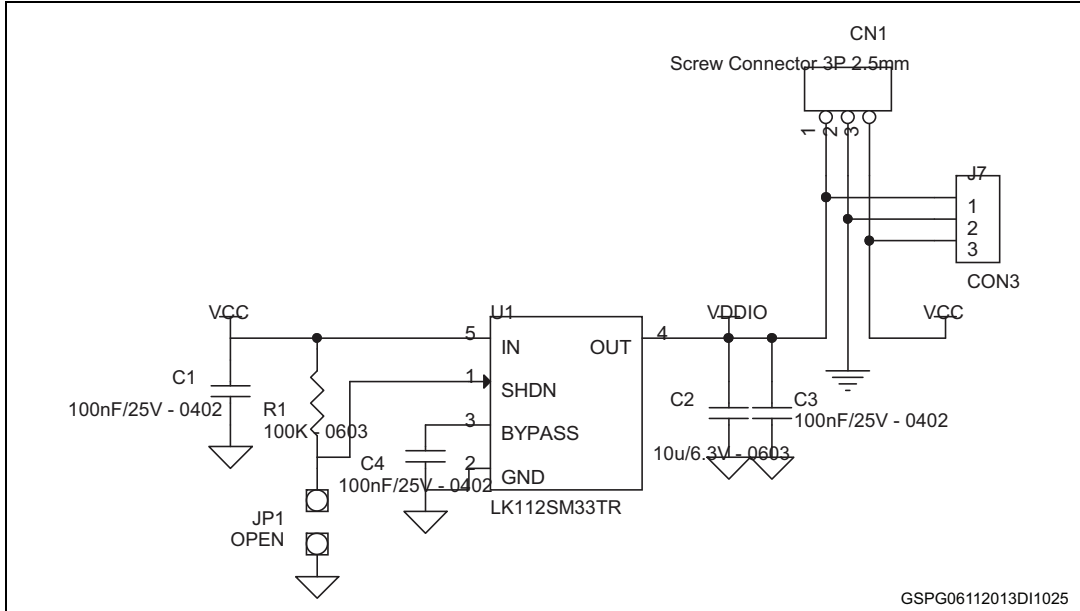

Figure 2. ST7580 reset button (micro-switch)

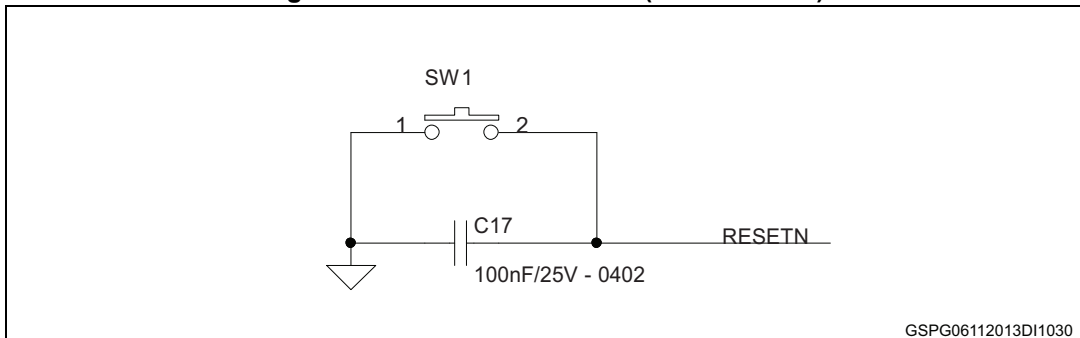

Figure 3. ST7580 UART interface

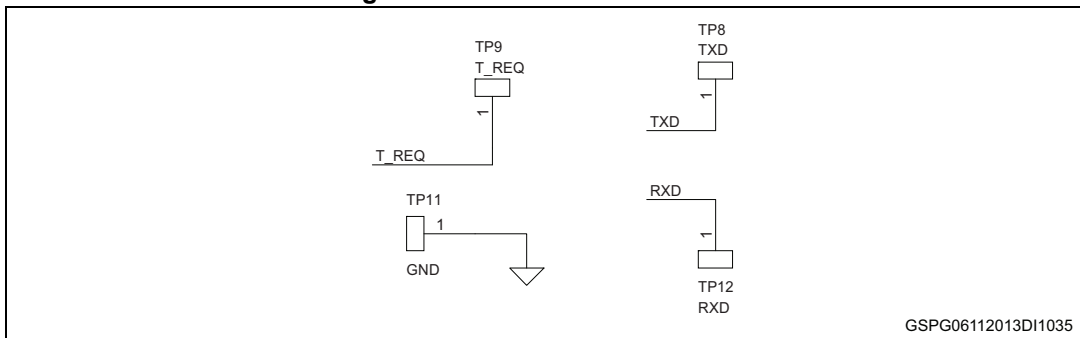
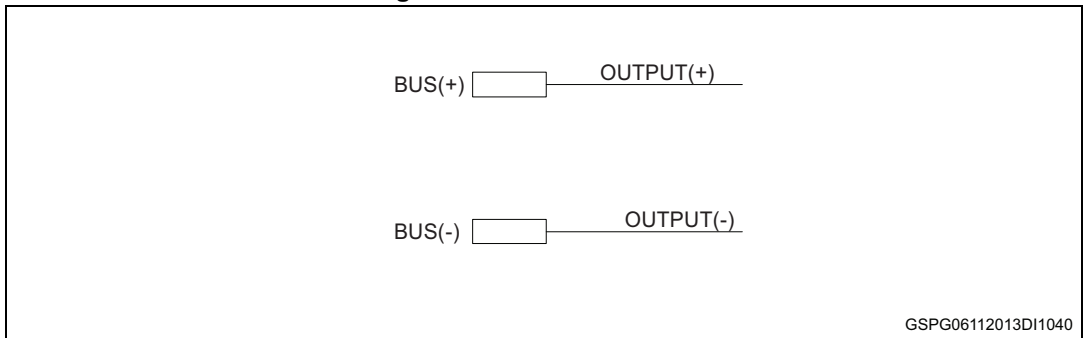
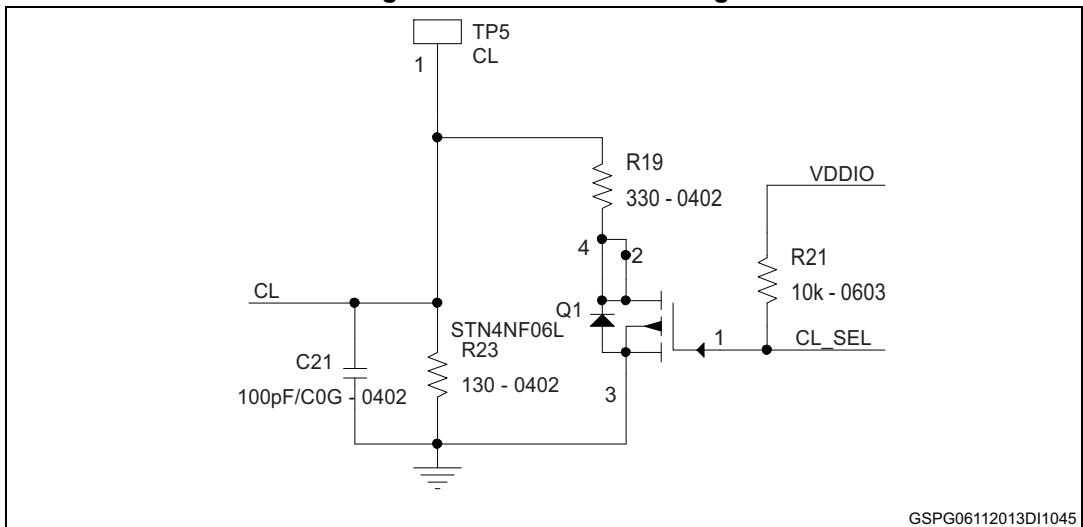

Figure 4. DC BUS / AC BUS



GSPG06112013DI1040

Figure 5. Current limit setting



GSPG06112013DI1045

Figure 6. Microcontroller connection

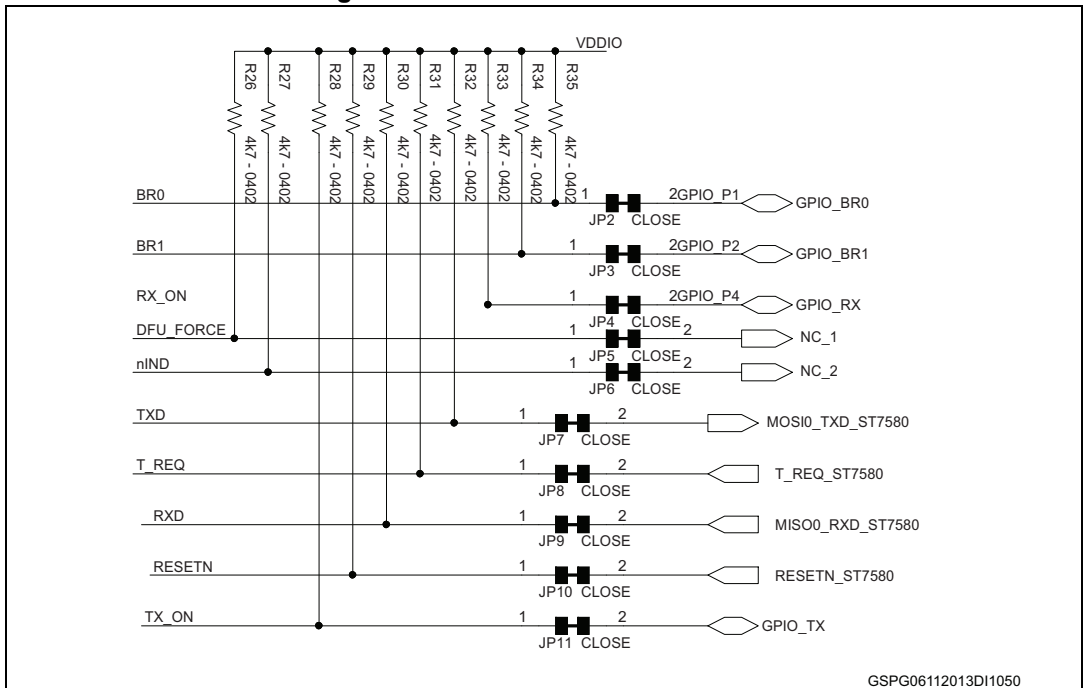

GSPG06112013DI1050

Figure 7. ST7580 module - PLM

GSPG06112013DI1055

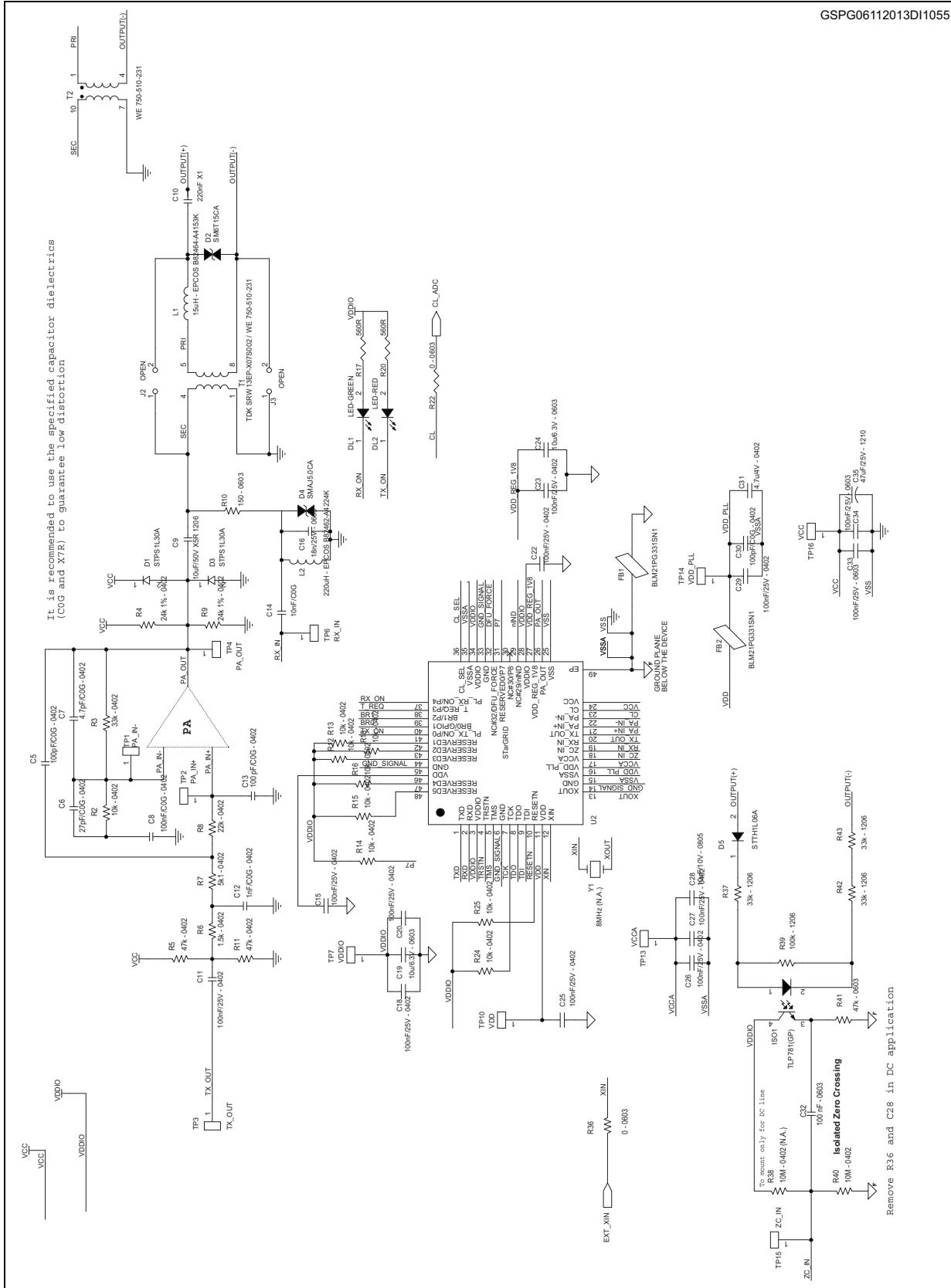

Figure 8. ST7580 module - MCU

GSPG06112013DI1100

