



STM32在数字能源解决方案

Terry Han

terry.han@st.com

意法半导体 中国区通用微控制器市场部门





STM32 portfolio

MPU

STM32MP1
Up to 1 GHz Cortex-A7
209 MHz Cortex-M4

STM32MP2
Dual 1.5 GHz Cortex-A35
400 MHz Cortex-M33

High-performance MCUs

STM32F2
Up to 398 CoreMark
120 MHz Cortex-M3

STM32F4
Up to 608 CoreMark
180 MHz Cortex-M4

STM32F7
1082 CoreMark
216 MHz Cortex-M7

STM32H5
Up to 1023 CoreMark
250 MHz Cortex-M33

STM32H7
Up to 3224 CoreMark
Up to 600 MHz Cortex-M7
240 MHz Cortex-M4

STM32N6
MCU with neural processing unit

Mainstream MCUs

STM32F3
245 CoreMark
72 MHz Cortex-M4

STM32G4
569 CoreMark
170 MHz Cortex-M4

Mixed-signal MCUs

STM32C0
114 CoreMark
48 MHz Cortex-M0+

STM32F0
106 CoreMark
48 MHz Cortex-M0

STM32G0
142 CoreMark
64 MHz Cortex-M0+

STM32F1
177 CoreMark
72 MHz Cortex-M3

Ultra-low-power MCUs

STM32L0
75 CoreMark
32 MHz Cortex-M0+

STM32U0
140 CoreMark
56 MHz Cortex-M0+

STM32L4
273 CoreMark
80 MHz Cortex-M4

STM32L4+
409 CoreMark
120 MHz Cortex-M4

STM32L5
443 CoreMark
110 MHz Cortex-M33

STM32U5
651 CoreMark
160 MHz Cortex-M33

Wireless MCUs

STM32WL
162 CoreMark
48 MHz Cortex-M4
48 MHz Cortex-M0+

STM32WB0
64 MHz Cortex-M0+

STM32WB
216 CoreMark
64 MHz Cortex-M4
32 MHz Cortex-M0+

STM32WBA
407 CoreMark
100 MHz Cortex-M33



Latest product generation

Radio coprocessor only

New series or lines introduced in 2024

Pre-announcement

China D-Power 应用分类



数字电源对主控的需求

数字电源需求

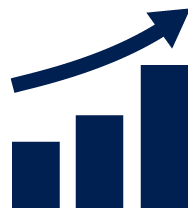

#1.高算力——从单一模块到系统集成

先进的内核，超高的主频、高执行效率和数学加速器

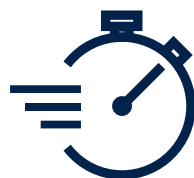

#2.采集精度高且快，控制精度高响应快

高精度多个独立ADC及多通道
高精度PWM和灵活的输出配置



#3.多样通讯

多种通讯接口（UART、I2C及CAN总线）

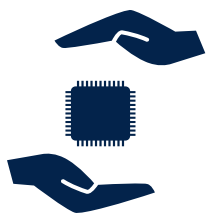

#4.高可靠性及安全性

安全加密机制
耐受恶劣高温125°C环境

STM32平台化应用

STM32数字电源PCS核心逆变

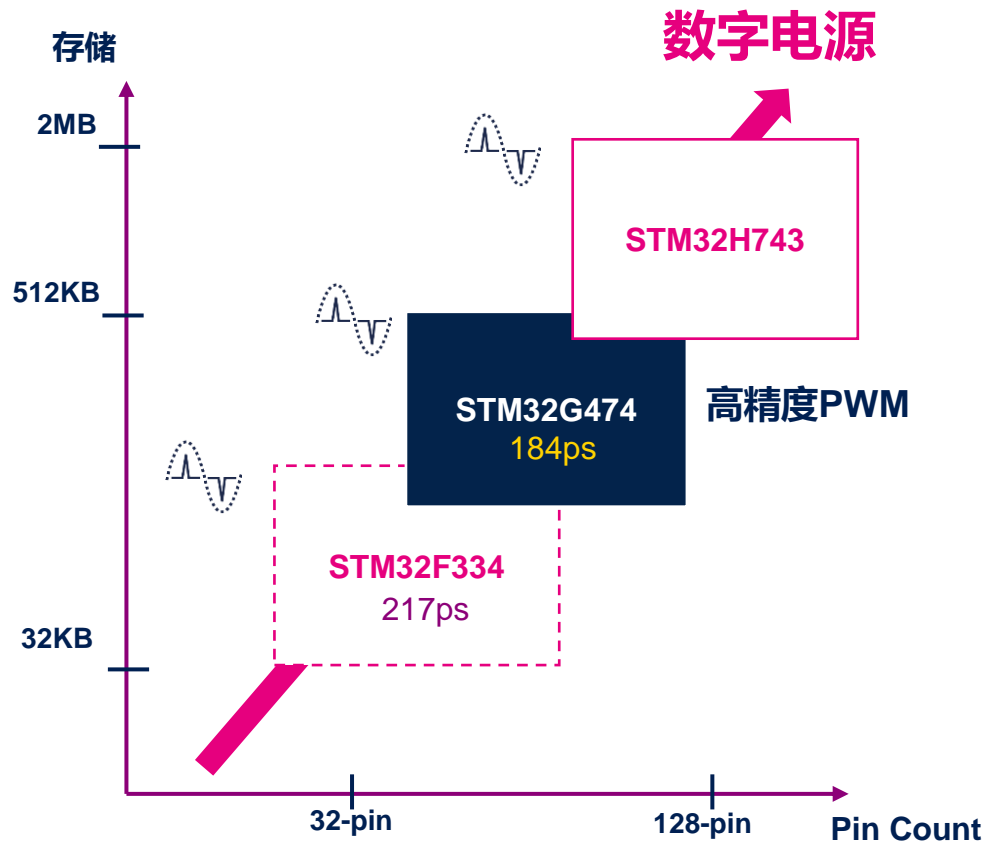

STM32G474

ADC + MCU(170MHz+ **Cordic**) + **PWM**

STM32H743

ADC + MCU(480MHz) + **PWM**

通信 / 服务器电源

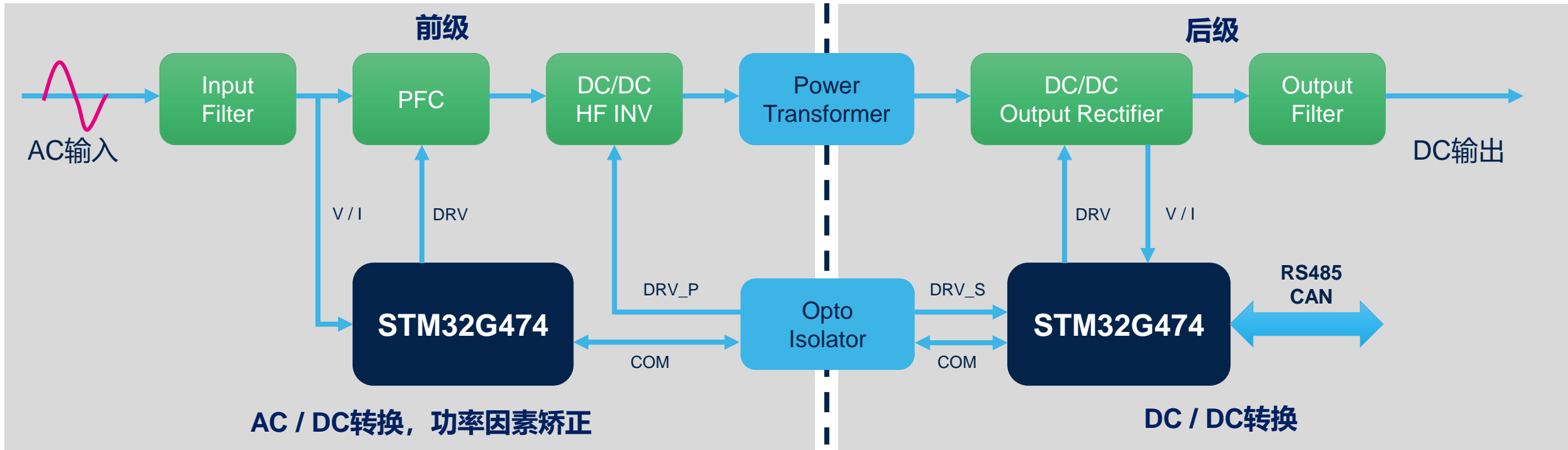

- 高精度定时器高达12路高精度PWM输出，可支持PFC和后级DC/DC的各种拓扑
- 数学加速器，提升运算效率
- 内置高速ADC、DAC及比较器，轻松完成信号采样
- 多种通讯接口 (UART、I2C及CAN总线)
- 耐受高温125°C

PFC/ LLC- STM32G474

Configurations of MCU key functions on digital

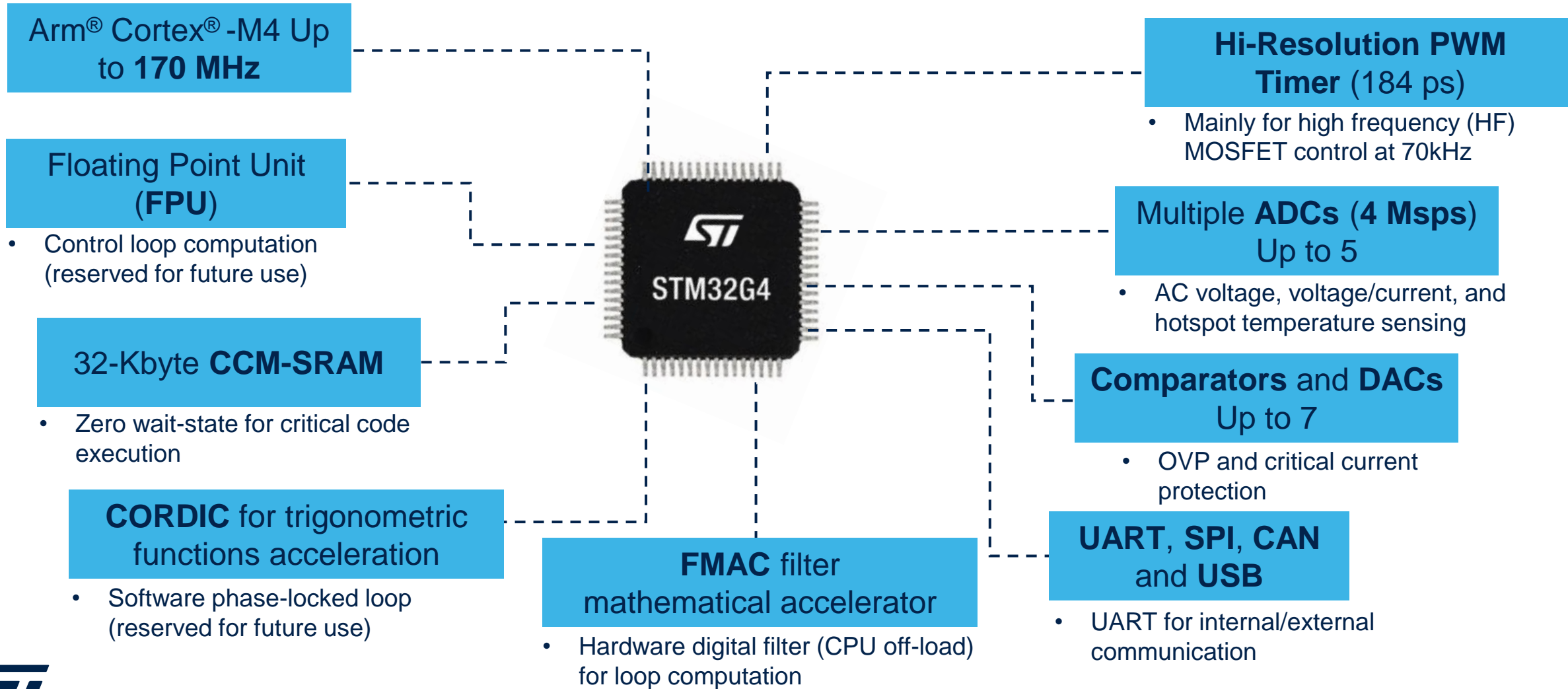

Key firmware features

Blanking + Soft-start Scheme in PWM for current spike at AC zero crossing

HW ZCD + software PLL for reliable AC phase detection

FMAC is used for current loop control to reduce CPU effort

STM32G474-PFC 框图

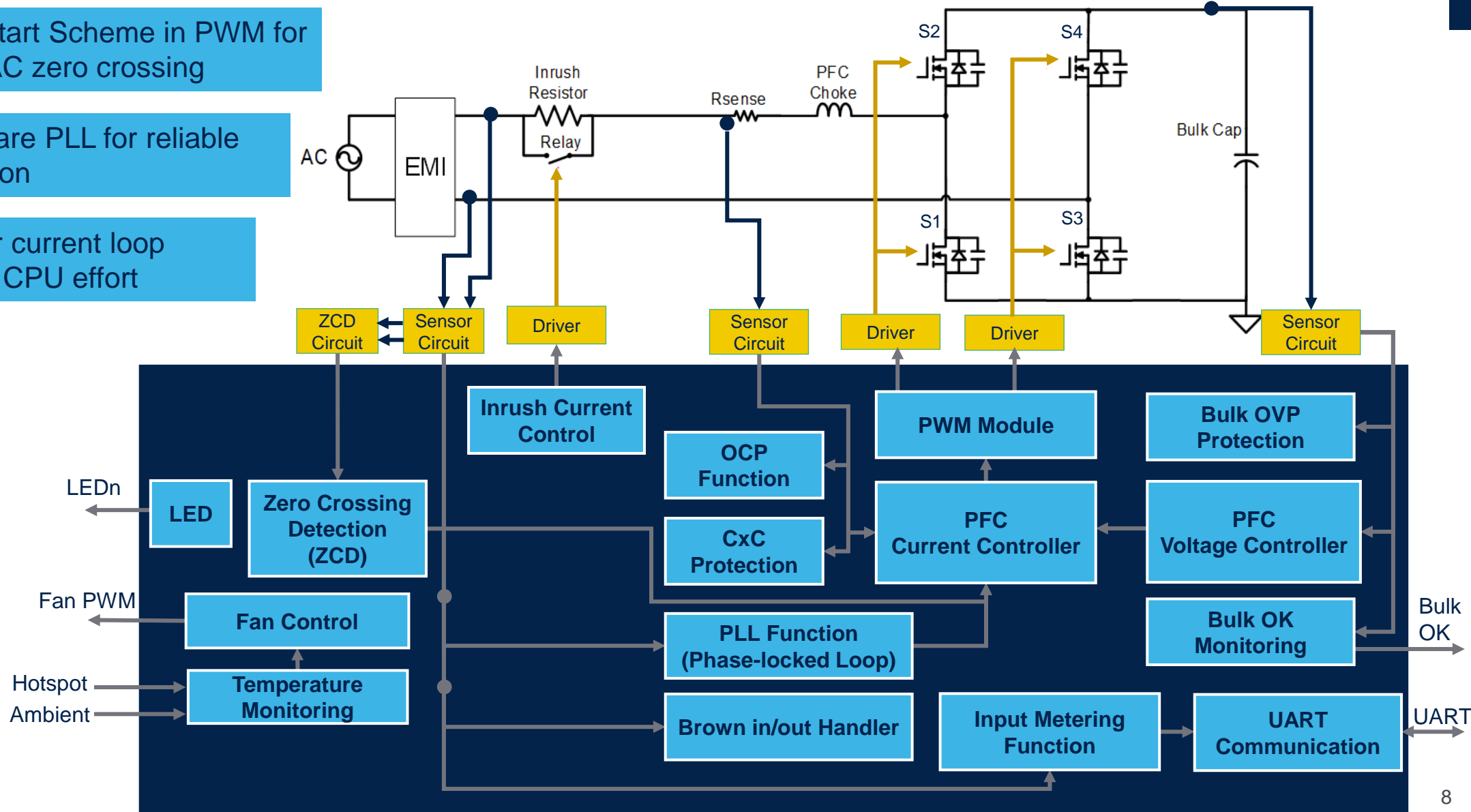

Key firmware features

Digital adaptive SR control to improve overall efficiency

Burst mode operation is adopted to reduce losses at light load

On-line coefficient tuning via UART

STM32G474-LLC框图

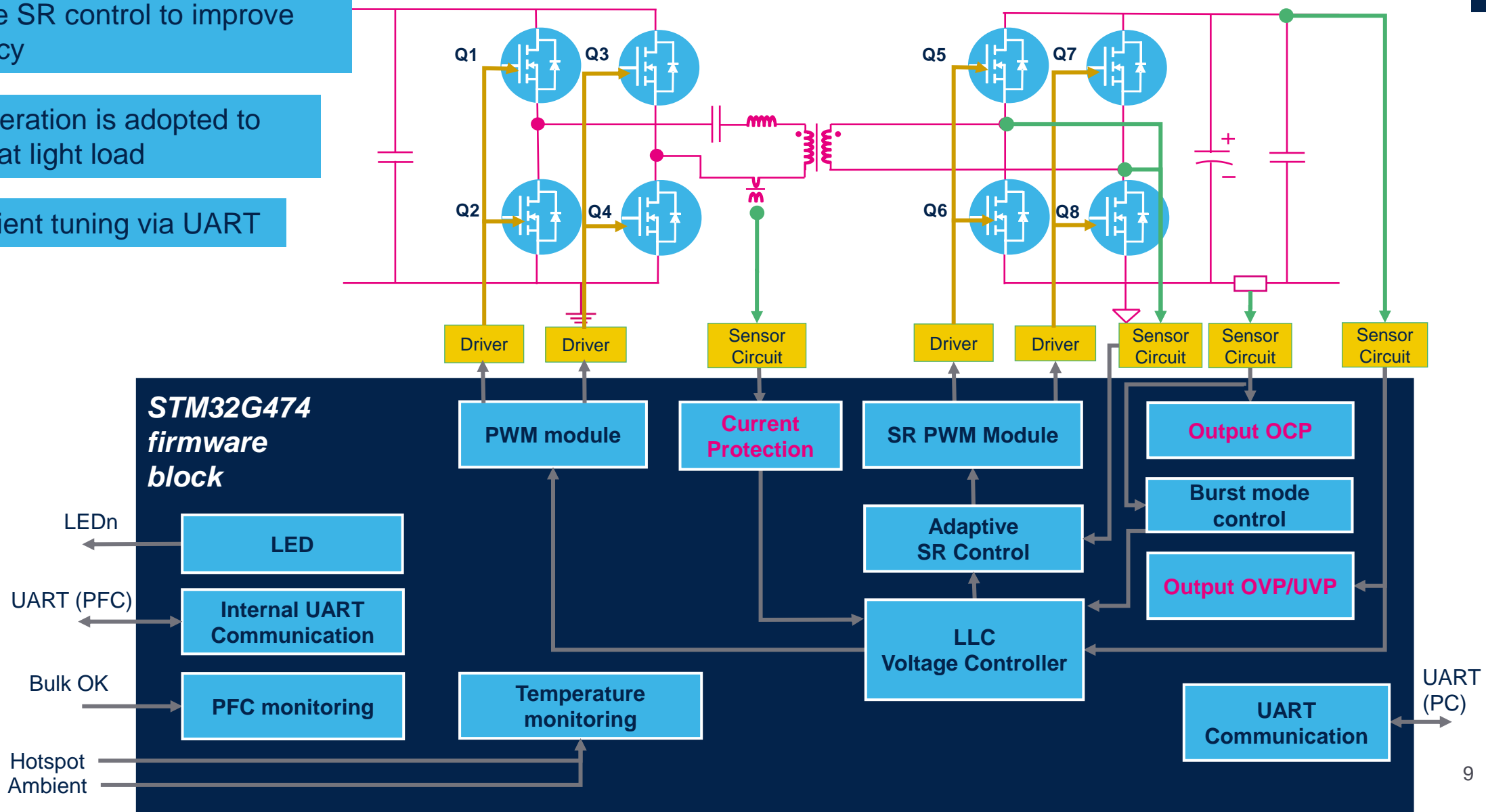

Solar inverter block diagram

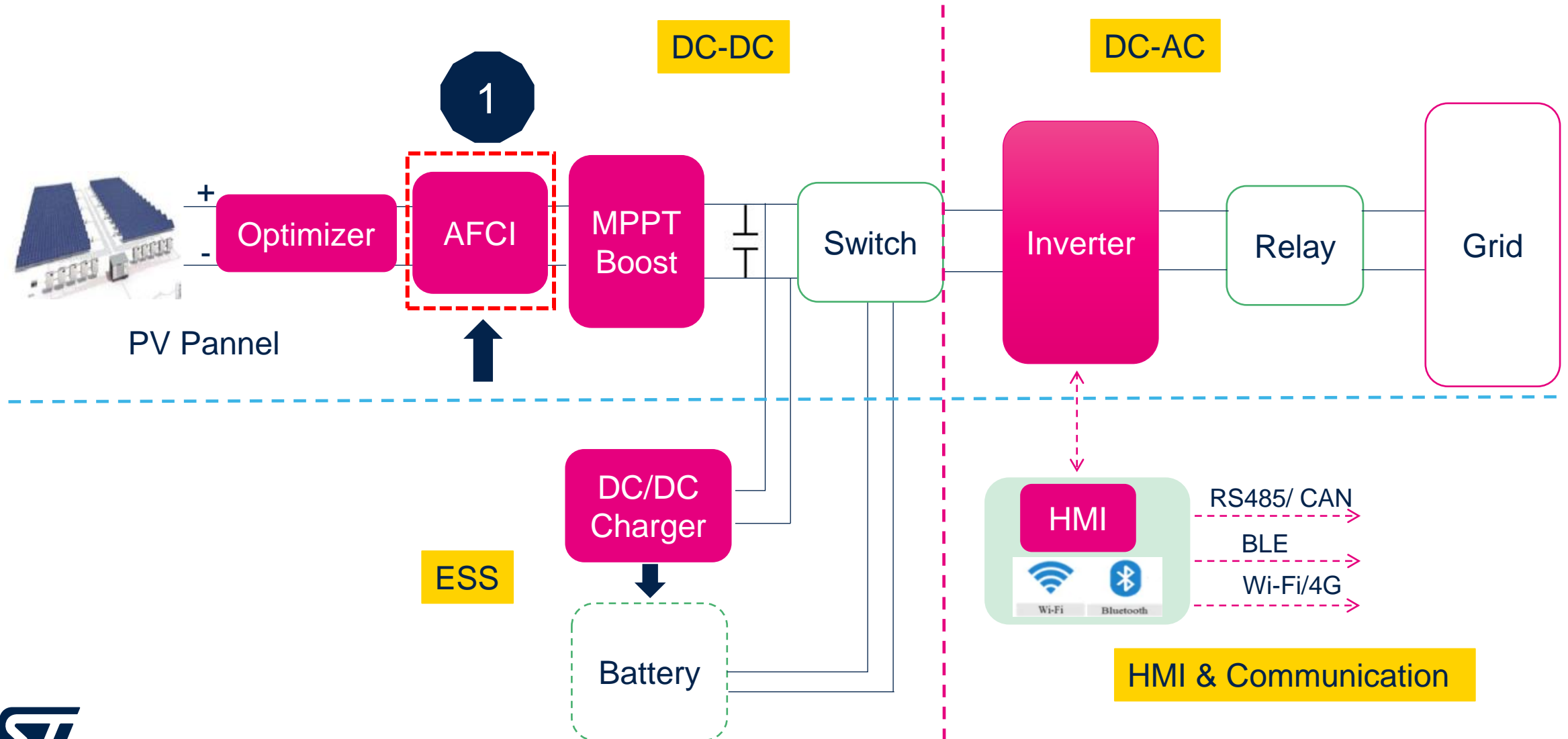

AFCI系统设计难点

逆变器噪声

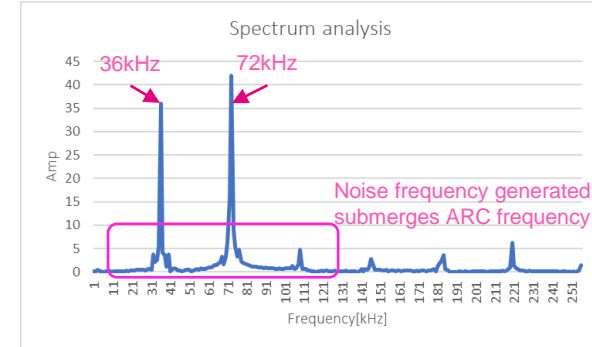
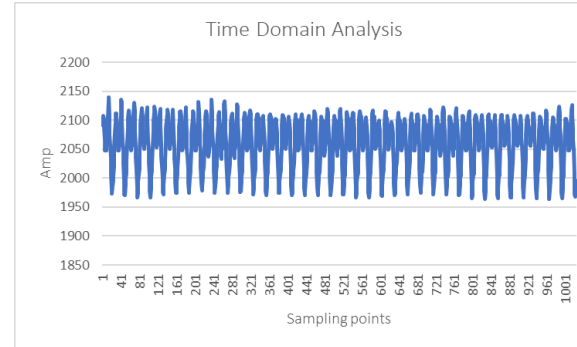
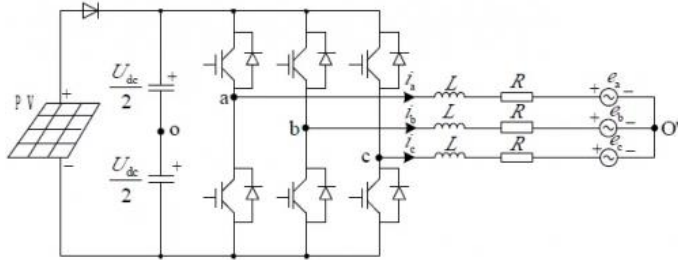

天气变化

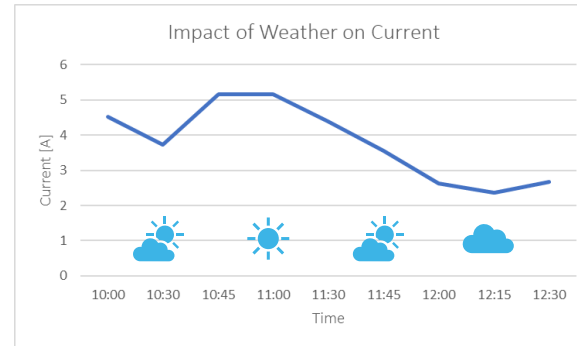
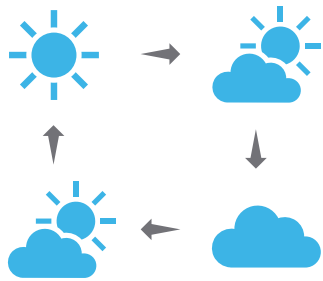

Date	Time	Weather	Voltage [V]	Current [A]	Power [KW]
15/07/2023	10:00	Nice, little cloudy	315	4.52	1.42
	10:30	Nice, little cloudy	277	3.74	1.04
	10:45	Nice, little cloudy	301	5.16	1.56
	11:00	Nice, little cloudy	300	5.16	1.55
	11:30	Nice, little cloudy	300	4.39	1.26
	11:45	Nice, little cloudy	320	3.55	1.10
	12:00	Cloudy	317	2.62	0.83
	12:15	Cloudy	334	2.36	0.79
	12:30	Cloudy	331	2.67	0.87

快速关断

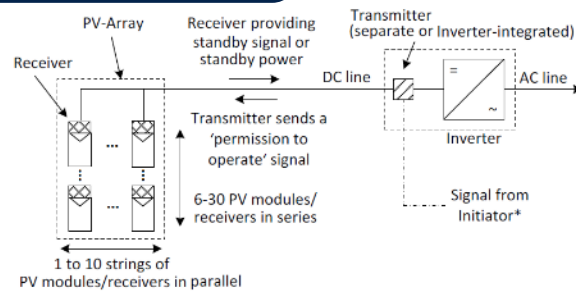

Requirements of the Power Line Communication

Symbol	Transmitter Specification	Min.	Nom.	Max.	Unit	Remark
W_1	Logic 1 Code Word	{-1, -1, -1, +1, +1, +1, -1, +1, +1, -1, +1}				+1 = mark, -1 = space
W_0	Logic 0 Code Word	{+1, +1, +1, -1, -1, -1, +1, -1, -1, +1, -1}				+1 = mark, -1 = space
F_M	Mark Frequency	131.236875	131.25	131.263125	kHz	6.25kHz × 21
F_S	Space Frequency	143.735625	143.75	143.764375	kHz	6.25kHz × 23
T_B	Average Bit Period	5.119488	5.12	5.120512	ms	(Time to complete one full duty cycle)/219
T_T	Transmission Period	168.943104	168.96	168.976896	ms	3 Words
T_Q	Quiet Period	901.029888	901.12	901.210112	ms	16 Words
T_C	Cycle Period	1069.972992	1070.08	1070.187008	ms	19 Words

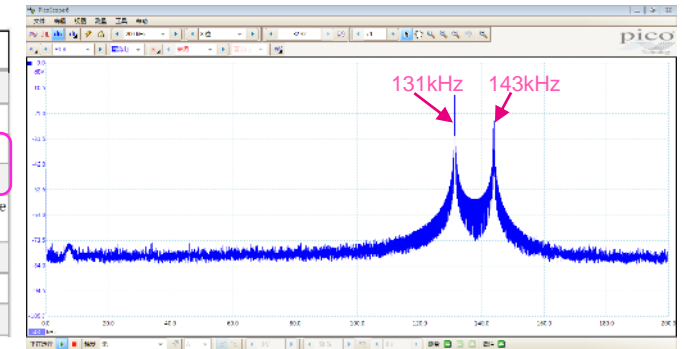

AFCI 项目流程 - PoC 阶段



ST提供的AFCI开发包

AFCI硬件 参考板1.0

包含STM32G4
和STM32H7的硬
件电路板用于数
据收集和测试



固件代码

- 数据记录工具
- 模型实时处理方法
- 相关的后处理

数据收集 PC工具

- 数据收集程序
- 实时检测程序

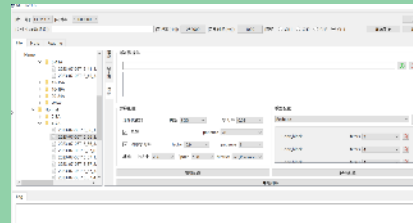

信号检测工具

用于分析采集到
数据的信号质量

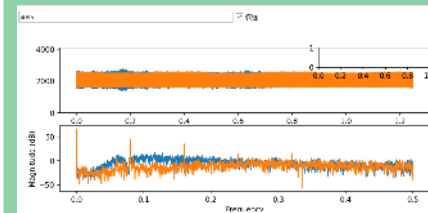

AFCI AI 模型 训练

(exe 文件)

用于训练采集的
数据来生成AI模
型

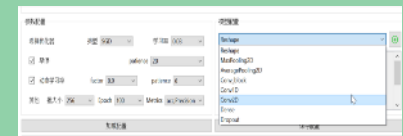

❖ 技术支持, 使用文档

ST 边缘AI 成功案例



INDUSTRIAL | DEMO

Fan anomaly detection based on vibrations

Learn to detect abnormal behavior at the edge on a vibrating machine.



INDUSTRIAL | CUSTOMER

AI solution for industrial predictive maintenance with NKE Watteco

Predictive maintenance solution for industrial equipment.



TRANSPORTATION | CUSTOMER

AI solution for monitoring automatic doors with Crouzet

Predictive maintenance on motors for automatic door motors.



INDUSTRIAL | DEMO

Anomaly detection in an electric motor

Current sensing to detect abnormal behaviors in motors.



INDUSTRIAL | CUSTOMER

AI solution for industrial predictive maintenance with Oxytronic

Predictive maintenance solution for industrial equipment.

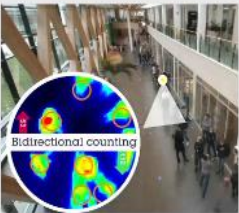

SMART OFFICE | CUSTOMER

People flow counting Sensor with Schneider Electric

An innovative approach to measure people flows using an in-house thermal sensor.



SMART CITY | DEMO

Acoustic scene classification

Identify different environments (indoor, outdoor, in-car) using a simple microphone.



WEARABLES | DEMO

Human Activity Recognition

Easily identify 5 different activities with a 3D accelerometer.



INDUSTRIAL | DEMO

People presence detection (visual wake word)

Human detection on high-performance MCU.



INDUSTRIAL | DEMO

Aftermarket wireless digit reader

Equip meters with aftermarket wireless & low-power readers.

基于AI的电弧故障断路器 (AFCI) 助力于安全和可持续发展。

Turnkey 参考设计方案，能有效快速部署最先进的AFCI方案

基于深度学习的检测器，可达到高检测准确率

高性能基于边缘计算的STM32G4 或是 STM32H7的MCU

TSV7xx 运放带来更灵活和准确的信号处理

经验丰富的支持团队，提供成熟的材料和流程

Solar inverter block diagram

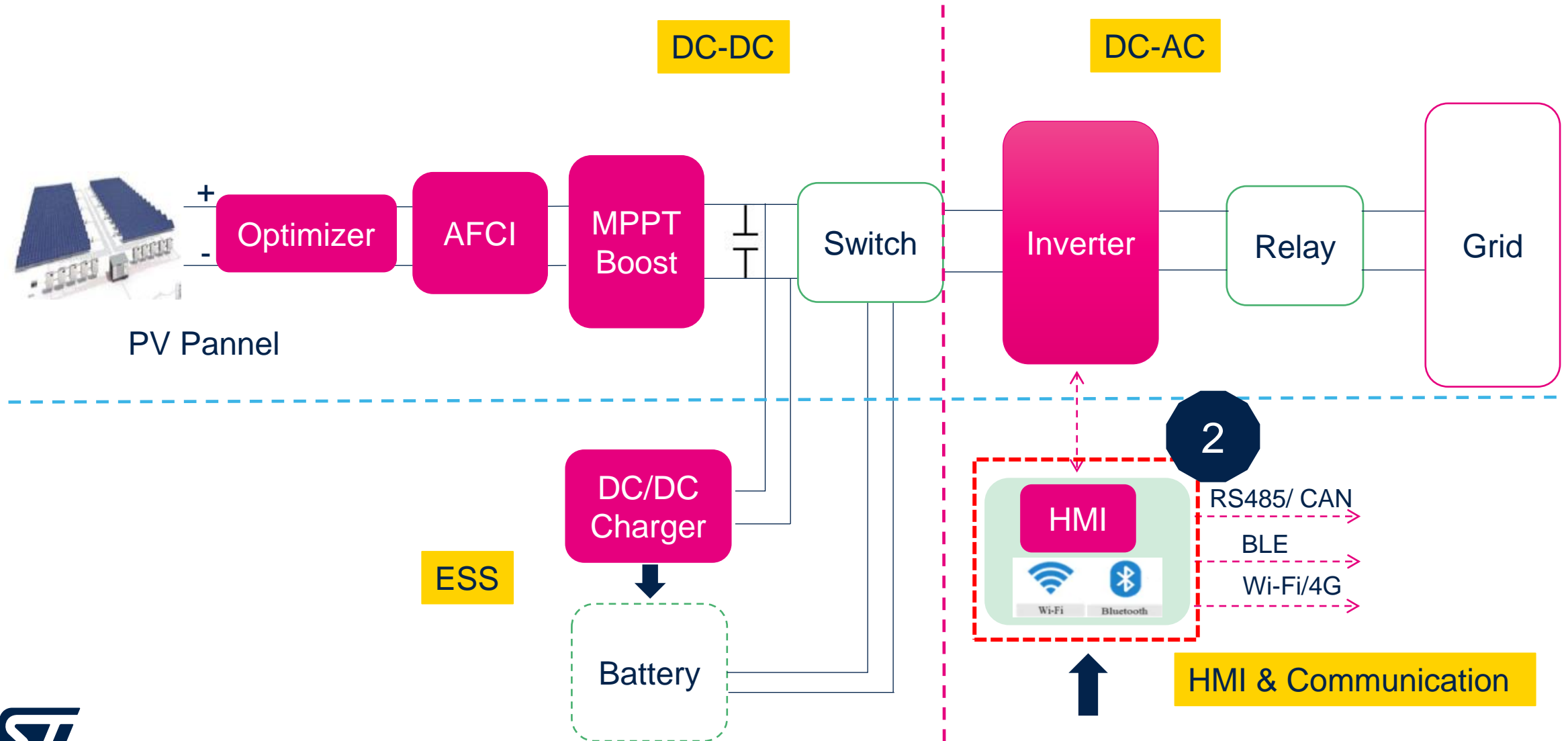



STM32 high-performance MCUs

Up to 3224 CoreMark and a rich set of peripherals

STM32H5	<ul style="list-style-type: none">• Arm® Cortex®-M33 at 250 MHz – 375 DMIPS• From 128 Kbytes to 2 Mbytes of Flash memory• High performance, scalable security, affordable
STM32H7	<ul style="list-style-type: none">• Arm® Cortex®-M7 + Arm® Cortex®-M4 FPU at 480 MHz – 1327 DMIPS and up to 600 MHz - 1284 DMIPS on single core Arm® Cortex®-M7• From 64 Kbytes to 2 Mbytes of Flash memory• High Performance, scalable memory and security
STM32F7	<ul style="list-style-type: none">• Arm® Cortex®-M7 + FPU at 216 MHz – 462 DMIPS• From 256 Kbytes to 2 Mbytes of Flash memory• Embedded flash & external memories
STM32F4	<ul style="list-style-type: none">• Arm® Cortex®-M4 + FPU up to 180 MHz – 225 DMIPS• From 64 Kbytes to 2 Mbytes of Flash memory• Cost-effective and power efficiency
STM32F2	<ul style="list-style-type: none">• Arm® Cortex®-M3 at 120 MHz – 150 DMIPS• From 128 Kbytes to 1 Mbyte of Flash memory• Foundation lines for performance and connectivity

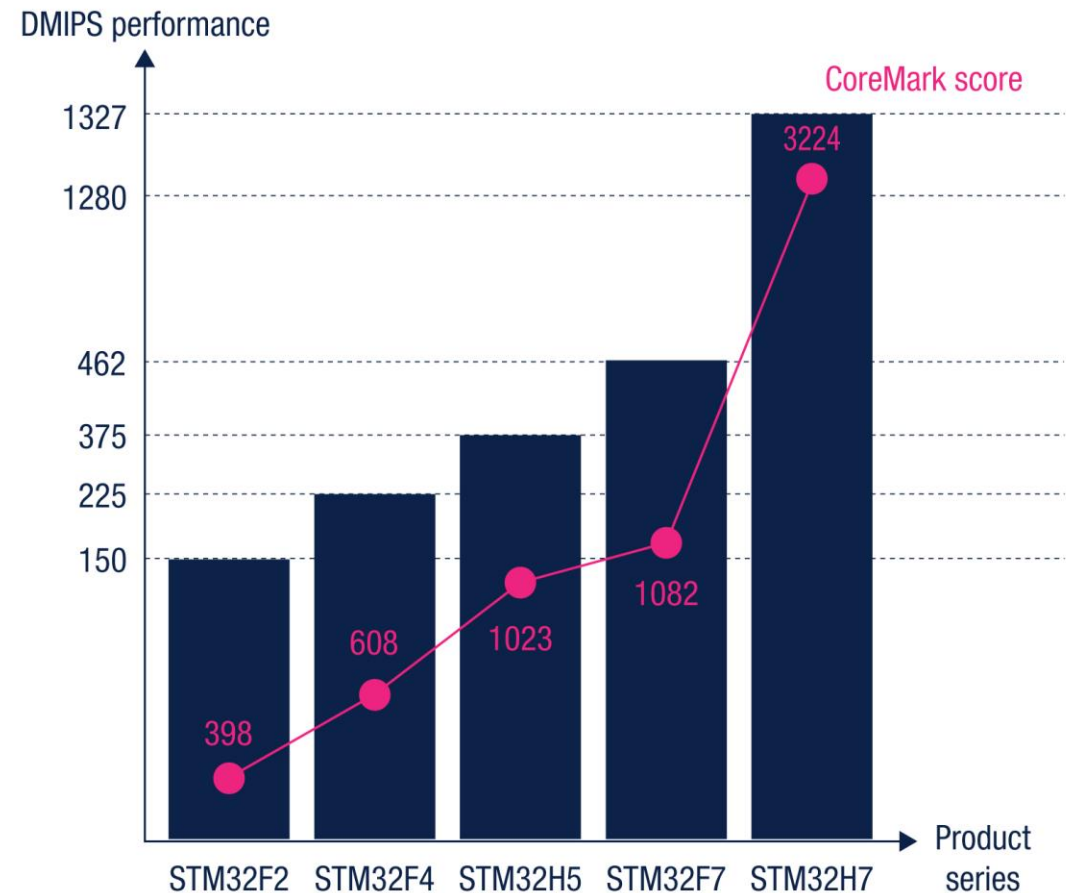

Legend:  Latest product series/lines generation



STM32H5 系列亮点

性能提升

- Cortex-M33内核, 1.5 DMIPS/MHz, 4.09 CoreMark/MHz
- 先进的40nm工艺, 使能
- 更高的系统主频
- 更快的flash访问
- 增强的系统架构



新特性, 高集成, 高性价比

借助40nm工艺:

- 更多的内部存储器 (FLASH+RAM)
- 更多的新特性外设
- 更小的面积



STM32F1/ F4 平台升级

功耗优化

- 40nm工艺优化动态功耗
- 静态功耗更低
- 其他功耗优化特征



先进安全功能

- Arm Cortex-M33内核与TrustZone®
- 产品生命周期
- 调试认证(Debug Authentication)
- 其他





STM32H5-2MB

高性能 & 高性价比

- CM33内核, 250Mhz主频, 375DMIPS
- TrustZone
- 集成丰富外设
- 先进安全特性和全新器件生命周期管理
- 高效动态功耗
 - 124uA/MHz w/ LDO
 - 64uA/MHz w/ SMPS
- VDD 1.71V to 3.6V
- TA: -40°C to 85°C/125°C
- 64 → 176pin

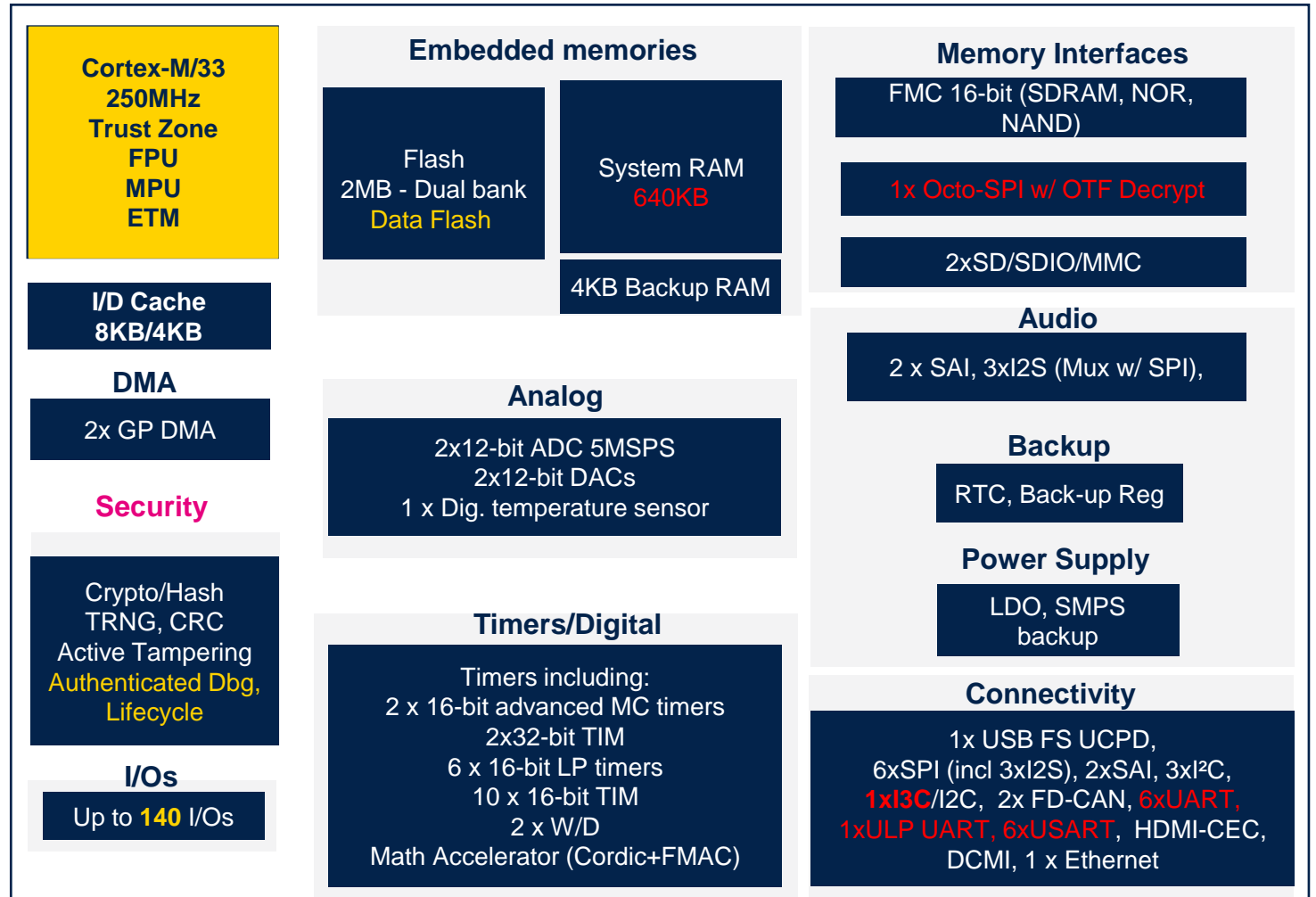



STM32H5



=

性能提升



+

功耗优化



+

新特性, 新外设



+

先进安全功能



平台升级

STM32H5系列不是简单替换F1/ F4系列！
而是带来更多应用特点

Solar inverter block diagram

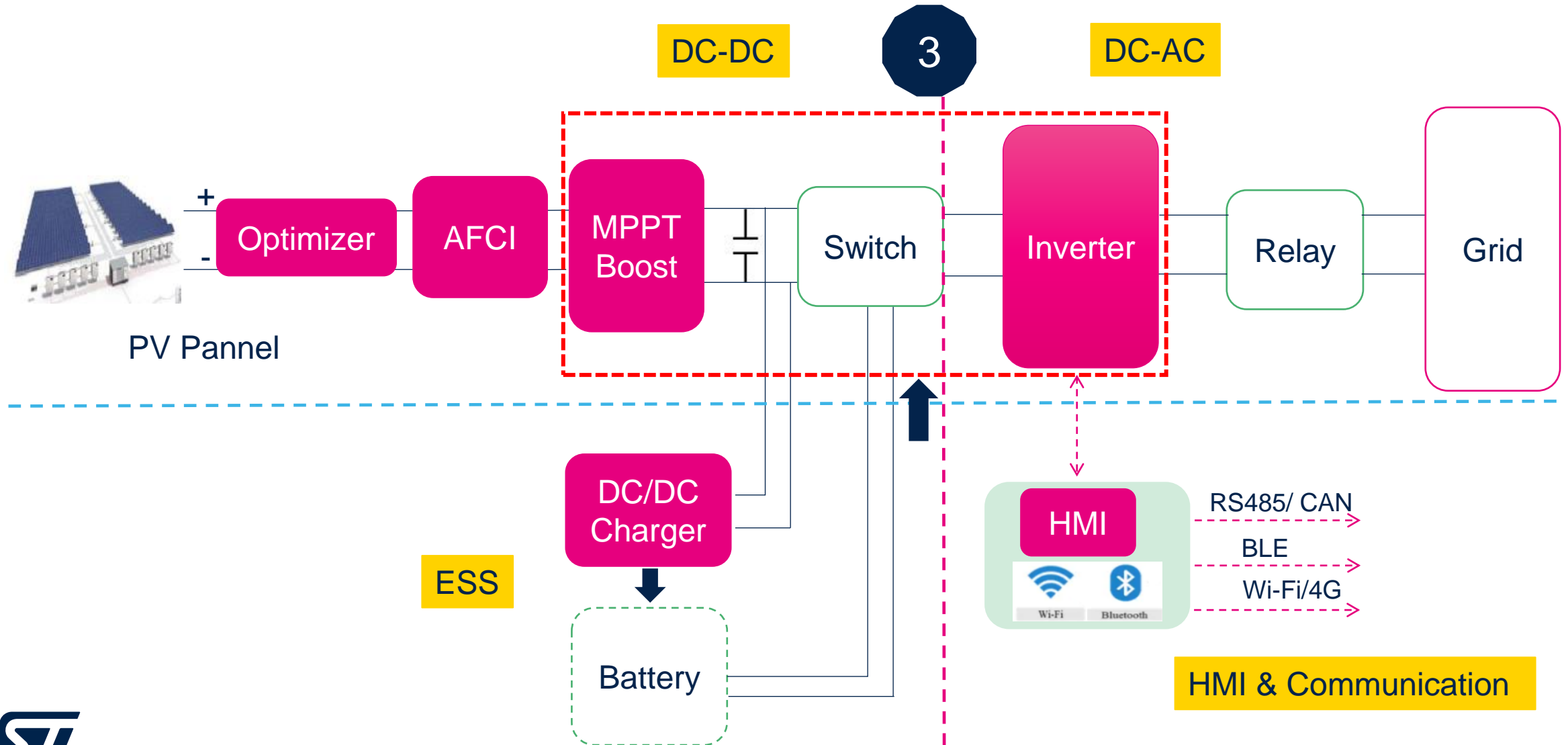

STM32G4产品一览表

参数	★STM32G474 高精度PWM型	STM32G473 性能型	★STM32G491 入门型	STM32G431 入门型
内核, 主频	Arm Cortex-M4, 170 MHz			
Flash (max)	512 Kbytes (2x256KB dual bank)		512 Kbytes single bank	128 Kbytes single bank
RAM (up to)	96 Kbytes			22 Kbytes
CCM-SRAM	32 Kbytes		16Kbytes	10 Kbytes
12-bit ADC SAR	5x 12-bit @4 MSPS		3x 12-bit @4 MSPS	2x 12-bit @4 MSPS
比较器	7x (17纳秒)		4x (17纳秒)	
运放 1% 精度	6		4	3
12-bit DAC	7		4	
USB FS Device	1			
CAN-FD	3x		2x	1x
高级电机控制定时器	3x (170 MHz)			2x (170 MHz)
12 通道 高精度定时器	1x (184ps)	-		
温度范围	-40 to 85°C / -40 to 125°C			
引脚数	48 to 128		32 to 100	

STM32G4 系列 – 关键词

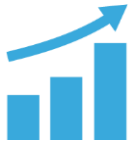

性能

- Arm® Cortex®-M4 at 170 MHz
- 213 DMIPS and 550 CoreMark® results
- 优化动态功耗(163µA/MHz)
- ART Accelerator™ (动态缓存)
- 数学运算加速器 (三角函数+数字滤波)
- CCM-SRAM Routine Booster (静态缓存)

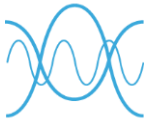

丰富的内置数模外设

- 运放 (内置增益), DACs, 比较器
- 12-bit ADCs 4Msps (硬件过采样 16bit)
- CAN-FD (up to 8Msps bit rate)
- 高精度定时器 V2 (184皮秒)
- USB type-C Power Delivery3.0
- 1%精度内置RC (-5~90dC), 2%(全温度范围)



功能安全与信息安全

- 双Bank Flash支持ECC (error code correction)
- 安全存储区域
- 硬件加密 AES-256
- SIL, Class-B
- SRAM支持奇偶校验

} 安全在线升级

} 功能安全设计包

完整的产品目录

- 补充已有STM32F3系列产品目录
- 环境温度范围-40dC 至 85 or 125dC
- 从 32 至 128-pin
- 从 32KB 至 512KB Flash

功能加速与减轻CPU负担

1. 三角函数 (Trigo)

- 非常有利于电机控制中所常用的的矢量运算(FOC)
- 精度可达20位

- 矢量旋转(极坐标到平面坐标): Sin, Cos
- 矢量转换(平面坐标到极坐标): 反正切Atan2, 模数Modulus
- 双曲正弦Sinh, 双曲余弦Cosh, 指数函数Exp
- 反正切Atan, 反双曲正切Atanh
- 平方根
- 常用对数 Ln

- 显著提高数学函数运算效率

➔ 比软件方式计算快**5倍**，精度高**10倍以上**，CPU负荷为**0%**

➔ 在电机驱动应用实例中，约提高**12%**控制环路速度

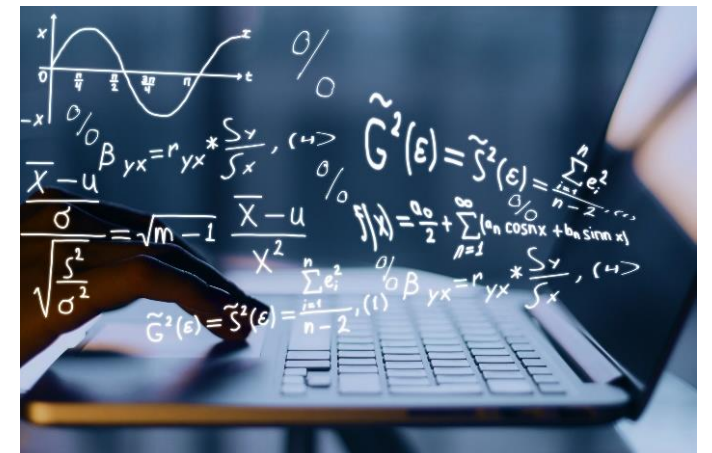



STM32H7系列延展

高性能与高性价比兼备

Dual-core Line

Single-core Line

Value Line

GUI

STM32H745/755 480+240 MHz SMPS 1027 + 300 DMIPS RAM 1 MB Flash up to 2 MB	STM32H747/757 480+240 MHz SMPS 1027 + 300 DMIPS RAM 1 MB Flash up to 2 MB
--	--

STM32H7A3/B3 280 MHz LDO 599 DMIPS RAM 1.4 MB Flash up to 2 MB
STM32H7B0 280 MHz SMPS 599 DMIPS RAM 1.4 MB Flash 128 KB

STM32H742 480 MHz LDO 1027 DMIPS RAM 692 KB Flash up to 2 MB
--

STM32H743/753 480 MHz LDO 1027 DMIPS RAM 1 MB Flash up to 2 MB
STM32H750 480 MHz LDO 1027 DMIPS RAM 1 MB Flash 128 KB

STM32H723/733 550 MHz LDO 1177 DMIPS RAM 564 KB Flash up to 1 MB
STM32H730 550 MHz LDO 1177 DMIPS RAM 564 KB Flash 128 KB

STM32H725/735 550 MHz SMPS 1177 DMIPS RAM 564 KB Flash up to 1 MB
STM32H730Q 550 MHz SMPS 1177 DMIPS RAM 564 KB Flash 128 KB

Arm® Cortex® core

Cortex-M7

Cortex-M7 & -M4



life.augmented



丰富的内部资源

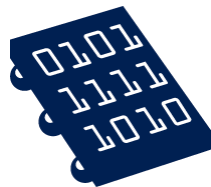

- 内置高达**2MB双区**的Flash, 支持ECC校验
- 内置高达**1.4MB SRAM** (多达1MB连续地址空间), 支持ECC校验
- 丰富的存储外扩接口: 32bit FMC, SDMMC及**Octo-SPI**

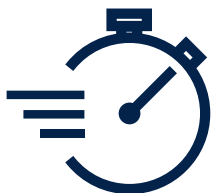

- **高精度定时器**: 精度高达**2.1ns**, 10路PWM输出
- 2个高级定时器, 可实现双电机控制
- 12个通用定时器及5个低功耗定时器

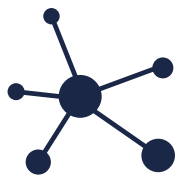

- 多达**11个U(S)ART**, 6个高速 SPI 和5个 I2C
- 多达3个新一代 **FD-CAN**总线, 通讯效率大幅度提升
- 2个USB OTG接口, 支持高速和全速传输
- 10/100 以太网控制器
- DCMI 数字摄像头接口 和 4个 SAI 音频接口

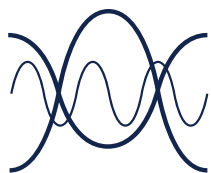

- 3个**16位ADC**, 采样速率高达**3.6MSPS**, 共有36通道
- DFSDM 数字滤波模块
- 2个DAC、2个模拟比较器和2个运算放大器

HRTIMER, 不仅仅是高精度而已...

高精度PWM

- 12 通道PWM信号输出, 频率和占空比精度可高达184ps
- 184ps 相当于 5.4GHz 定时器时钟
- 自带电压与温度补偿, 保证精度不漂移

高灵活度PWM

- 7个独立时钟计数器 (1主+6从), 可相互配合生成灵活多样的PWM波形
- 可灵活配置成 6 组互补输出的 PWM 对
- 内置信号枢纽 Crossbar, 单个 PWM 周期内最多可达 32个 set/reset 触发源
- 灵活角色可配Master/Slave, 更适合多项控制

多事件响应

- 6个模拟与数字的错误输入源
- 10个事件输入源
- 事件响应可配置: 计数响应, 窗口内连续事件响应等

12个独立输出通道

- 可支持任意一种常见拓扑:
 - 1x 12 PWM (三项交错LLC)
 - 12x 1 PWM (多项独立 buck 调光控制器)
- 每一路定时器均有可配置参数DMA, 整个HRTIM单元亦有高级DMA功能, 可部分或整体更新参数

STM32 软件工具

完整支持Arm Cortex-M 开发生态

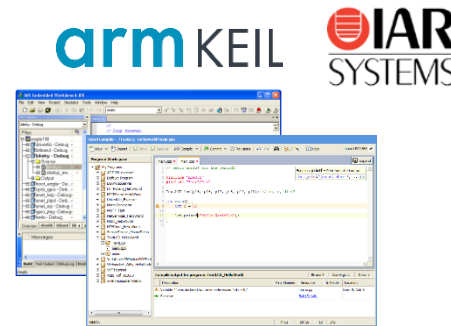
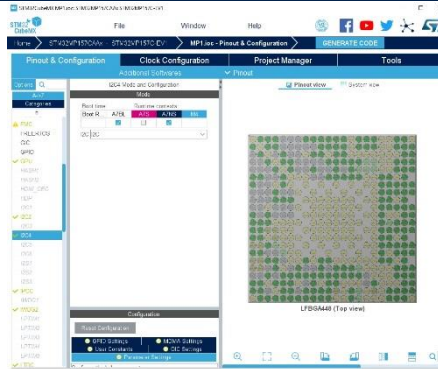

All-in-one STM32 programming tool
Multi-mode, user-friendly



STM32CubeMX

STM32CubeMX

- 配置及初始化代码生成
- 解决资源配置冲突

IDEs Compile and Debug

灵活的方案

- 第三方 IDE, 如 IAR、Keil
- 免费的基于Eclipse的官方IDE STM32CubeIDE*

STM32 Programming Tool

STM32CubeProgrammer

- Flash 和/或 系统存储 读写
- 支持 GUI 或 命令行 界面

STM32数字电源开发支持

STM32 方便数字电源设计

数字电源开发SDK (支持PFC和PSU
拓扑结构的例程生成器和固件驱动库)
硬件评估板, 文档, 开发工具

创新的产品, 外设 及软件算法

- 高精度定时器支持各类电源拓扑
- STM32集成丰富的高性能模拟外设
- 支持硬件协处理器加速计算性能
- Biricha 第三方数字电源设计培训 (ST 认证第三方)

ST 宽泛产品线支持

更多的功率器件选择
基于STM32设计实现的端到端数字电
源解决方案

支持PFC 和 PSU STM32CubeMX

基于ST 评估板, 支持电流或电压模式
运行的固件开发包, 实现了 PFC 和
PSU 拓扑结构。

最新消息

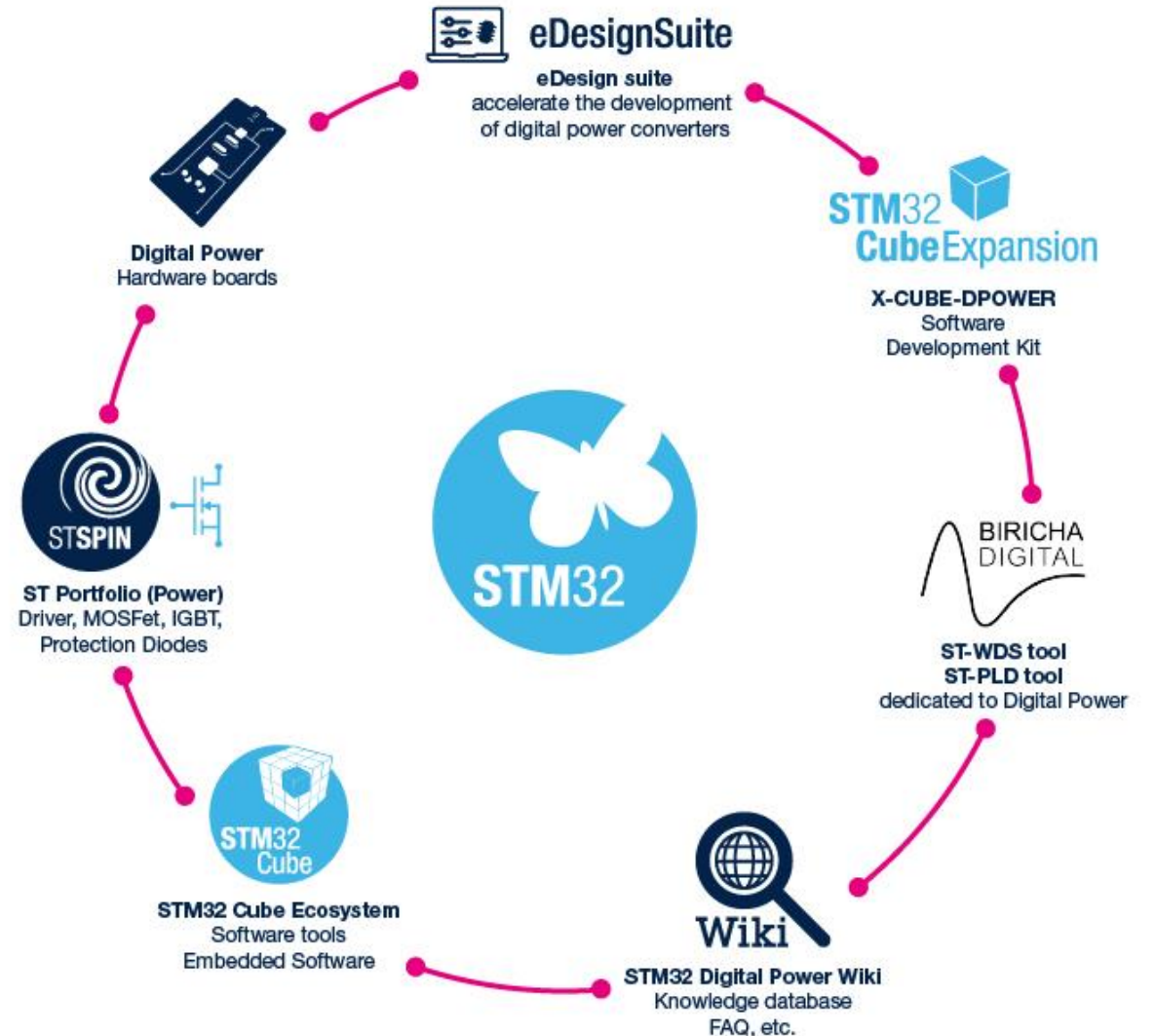

STM32数字电源



STM32CubeMX数字电源例程库 X-CUBE-DPOWER

支持的拓扑结构:

- 交错 Boost PFC 变换器, 平均电流模式
- 全桥移相 DCDC 变换器, 恒流 / 恒压输出模式
- Buck 和 Boost 电源变换器, 电压和电流控制模式



STEVAL-ISA172V3

基于零极点补偿(2P2Z, 3P3Z) 环路控制

- 卓越控制环路, 提供更好的性能和稳定性
- 数字实现 III 型控制器
- 控制参数生成由 Biricha Digital公司提供的ST-WDS/ST-PLD工具完成
 - 对 STM32 用户免费



B-G474E-DPOW1



More Than Silicon: DSMPs use case

- Microcontroller requirements
- Functional safety requirements
- Security requirements
- Graphics / HMI requirements
- Edge AI requirements

**Supported by all
STM32 MCUs & MPUs**

	SIL Functional Safety Package
	Class B Functional Safety Package
	STM32 Security Framework
Expansion packages for secure firmware update and more	
	TouchGFXDesigner PC tool for UI generation
X-CUBE-TOUCHGFX Graphical library Expansion Package	
	ST Edge AI Suite 50+ case studies 10+ free tools 20+ resources

15 kW 3phase T-Type bi-directional PFC with SiC and digital control

STDES-PFCBIDIR

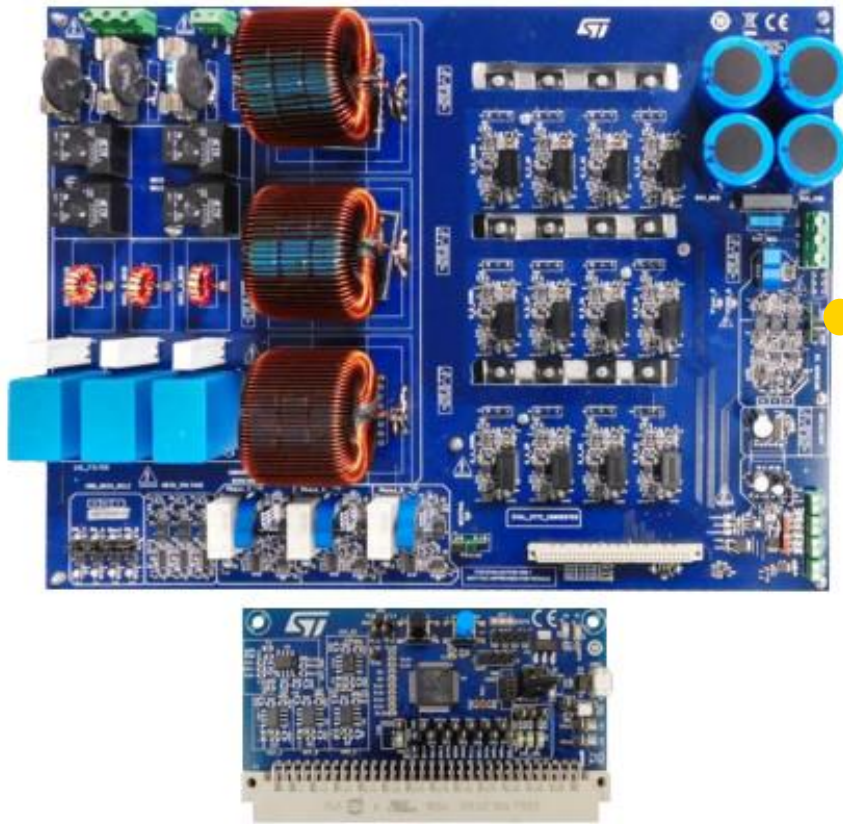

Enabling

- AC to DC rectifier mode:
 - Power factor control (PFC) $PF > 0.99$
 - THD $< 5\%$
- DC to AC inverter mode:
 - Active and reactive power control
 - Integrated grid connection solution
- Passive components weight and size reduction

Based on several components:

- SCTW35N65G2V (55 m Ω 650 V SiC MOSFET)
- SCTW40N120G2V (75 m Ω 1200 V SiC MOSFET)
- **STM32G474RET3 (Cortex-M4 MCU)**
- STGAP2S (Galvanic isolated gate driver)
- VIPer26K (High voltage converter)
- STLM20W87F (Analog temperature sensor)
- TSV91x (Wide-bandwidth rail to rail Op-Amps)
- LD29080 (LDO)



STM32 本地化资源, 提供海量信息



ST 官网

www.ST.com



STM32 中文官网

www.STMCU.com.cn



STM32中文技术支持邮箱:

mpu.china@st.com
mcu.china@st.com



大学计划联络邮箱:

edu.china@st.com



技术培训报名网页:

www.stmcu.com.cn/training



ST 中文论坛

shequ.stmicroelectronics.cn



ST Community 全球论坛

<https://community.st.com/s/>



STM32 21ic论坛

<http://www.21ic.com/stm32>



STM32 MCUs Wiki 页面

wiki.st.com/stm32mcu



STM32 MPUs Wiki 页面

wiki.st.com/stm32mpu



STM32 GitHub页面:

github.com/STMicroelectronics



STM32微信订阅号



STM32视频号



STM32微信服务号



线上课程平台



@STM32单片机



www.st.com/stm32-digital-power

Our technology starts with You



Find out more at www.st.com

© STMicroelectronics - All rights reserved.

ST logo is a trademark or a registered trademark of STMicroelectronics International NV or its affiliates in the EU and/or other countries.

For additional information about ST trademarks, please refer to www.st.com/trademarks.

All other product or service names are the property of their respective owners.



life.augmented