

Z01 and ACS behavior compared under fast voltage transients

Introduction

Home appliances such as washing machines, refrigerators, and dishwashers integrate a lot of low-power loads such as valves, door lock systems, dispensers, and drain pumps. These loads are mains-powered in on/off mode, and are mostly controlled by triacs or relays.

In most cases, the AC switching function now needs to be directly driven by a microcontroller unit (MCU) and it must withstand the AC line transients to make the system compliant with the electromagnetic compatibility (EMC) standards.

STMicroelectronics ACS (alternating current switches) have been designed to meet these needs, as shown in this application note. Compared to triacs, they offer high robustness and dV/dt capability, while contributing to a substantial reduction of the overall electronic board size.

The application specific discrete (ASD) concept, developed by STMicroelectronics, allows several devices, such as diodes, thyristors, transistors, and some passive components used to make a complete function, to be integrated on the same silicon die. This technology has been used to develop the new ACS structures.

An ACS embeds an integrated driver, a clamping structure, and a bidirectional, thyristor-type switch (see [Figure 1](#)). The primary loads to be targeted by these new devices are high inductive loads like valves, pumps, door locks, widely used in home appliances applications, where the serial inductance can reach the teens of Henry and the turn-off operation can thus cause many problems. The second section explains how the clamping feature of ACSs enables them to directly drive any inductive load without any external clamping device, such as metal oxide varistors, and how ACSs can also sustain overvoltages coming from the mains.

Silicon devices are subjected not only to surge voltages but also to fast transient voltages, as described in the IEC 61000-4-4 standard. They must not only present clamping ability but also high immunity to high dV/dt rates. The results of tests reported in this application note show the maximum levels withstood by ACSs and triacs, for different gate sensitivities.

Figure 1. ACS symbol description

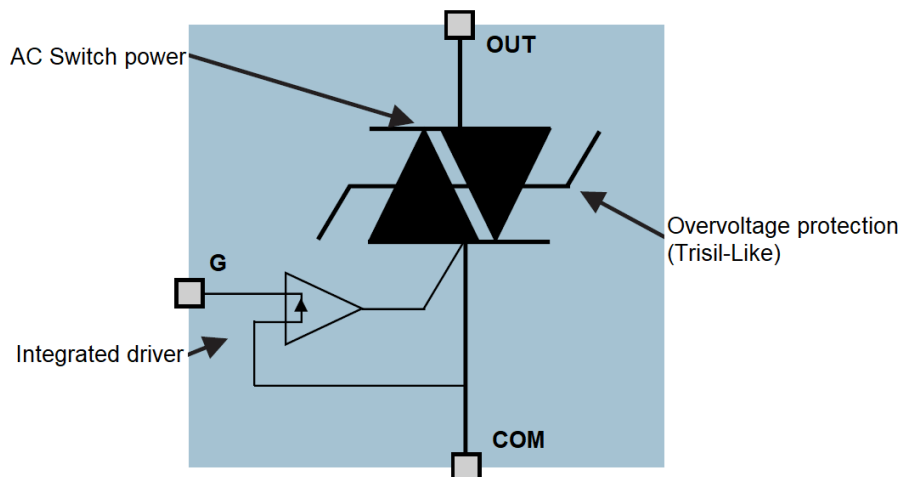

1 ACS: an overvoltage protected AC device

1.1 Inductive load switch-off

In the case of AC high voltage operation with high inductive loads, their windings show a high series resistance (a few k Ω) and a high series inductance (tens of Henry). Hence, they absorb a low rms current (typically, 10 to 50 mA). In this case, the rate of decrease of the current is low and an automatic switch turn-off may result when its current becomes lower than the holding level [1].

There may be an overvoltage if there is still some current through the inductive load. The inductive energy thus creates a back electromotive force. If this overvoltage is not clamped, it can reach the device breakdown level and damage it.

ACSs are self-protected against overvoltage. They can sustain their holding current in such an operating mode, as shown in Figure 2.

Figure 2. Valve turn-off - typical oscillogram with the AC108-8SP device

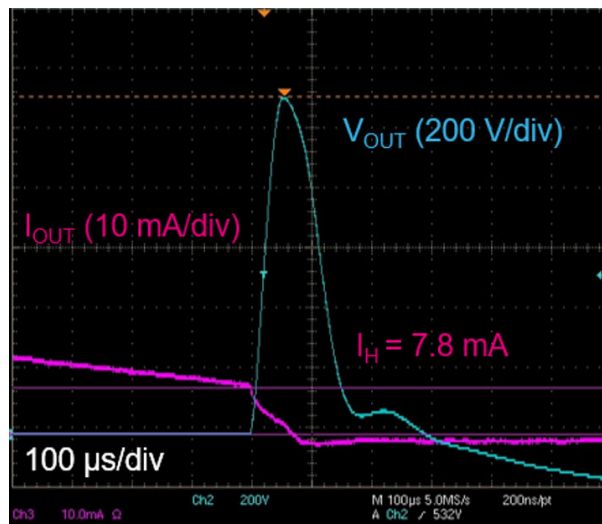

1.2 IEC 61000-4-5 standard

The IEC 61000-4-5 standard has been established to check whether systems can continue to work after there has been a voltage surge superimposed on the mains. A standard voltage waveform has been chosen which embodies typical overvoltages due to lightning or the disconnection of running inductive loads from the line.

Considering a home appliance application, the installation class and test level are 4 as defined in the IEC61000-4-5 standard. Hence, a 2 kV surge is applied between line and neutral.

As the line to neutral surge can appear at peak mains voltage, the overall voltage can reach 2.4 kV (2 kV surge + peak mains voltage for 240 V rms line). This is higher than the breakdown level of the silicon devices used in appliances. To prevent the destruction of components, designers use a varistor connected across silicon devices.

When a surge occurs and the ACS is off, the mains overvoltage is first clamped by the device. But an excessive energy surge can raise the ACS current above its breakover level.

Then, the switch turns on in breakover mode [2], and [3]. Such an event is particularly stressful on the semiconductor especially if the current and its rates of increase are both high. The worst case occurs when ACSs are driving low resistance, non-inductive loads (only a few tens of μH as a series parasitic inductance).

For example, Figure 3 and Figure 4 have been recorded with a thermal active door lock system at a low temperature controlled by an ACS108-8SA device. The 2 kV surge is superimposed on the 230 V, 50 Hz mains and synchronized with its peak value, as shown in Figure 3. Figure 4 shows the device turn-on in this mode. As the load was previously off, its resistance is cold and equals 150 ohm. In this case, the current rises at a rate of 100 A/ μs and reaches 15 A. Such transient surges would damage triacs, but not ACSs, as they are designed to turn on in breakover mode. The varistor is then no longer needed in parallel across ACSs, unlike triacs. The difference between ACS and triac + varistor is that, with the ACS, the load is switched on during a half or one mains cycle. This can be accepted as such events happen a few times in the system's life.

Figure 3. 2 kV surge on the mains

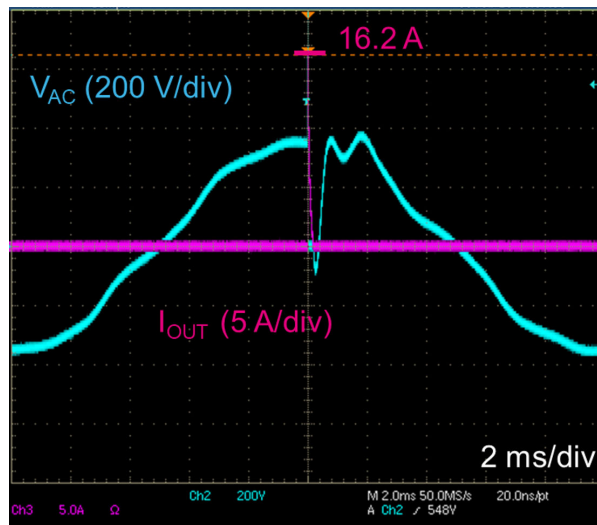
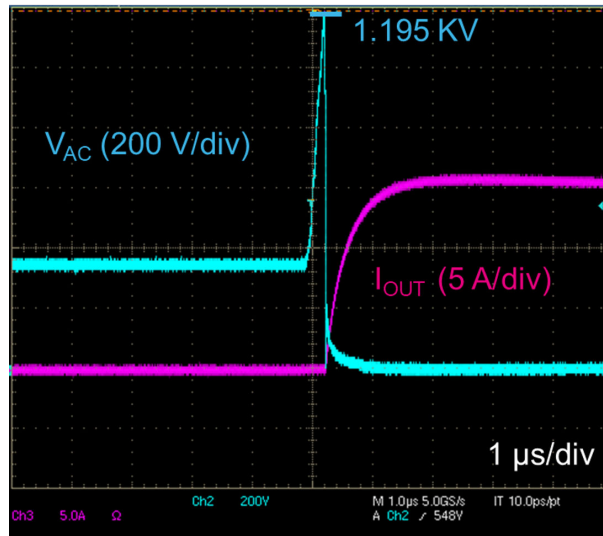

Figure 4. ACS breakover



2 Fast transient immunity tests

2.1 Standard requirements and mains filter utility

IEC 61000-4-4 tests propose two different kinds of stress. One, called the “supply test,” consists of applying the bursts through 33 nF capacitors to the line, neutral, ground, or combinations of these terminals. The second EN61000-4-4 stressing mode is to apply the bursts through a typical 100 pF capacitor (achieved with an aluminum sheet), directly to the I/O ports of the system.

The I/O port test is in fact required for systems where there are control wires, as for computers (wires between the keyboard and the central unit). But appliance manufacturers perform similar tests to check if their products can withstand fast voltage transients.

For both cases, the system under test is placed 10 cm above the burst generator reference plane. As the voltage waveforms increase and decrease respectively in 5 and 50 ns, the impedance of the parasitic capacitance between the system board and the plane is very low for such high dynamic waveforms. This results in the application of the major part of the burst directly across the mains supply plug of the system under test. The following figures show the line to neutral voltage measured during a 2 kV supply test. We see that the voltage reaches up to 1.41 kV when no filter is used at the mains input of the system. If a filter, such as that described in Figure 7, is added, the overvoltage, caused by the 2 kV burst falls to 584 V. This is below the breakdown voltage of most triacs used in 230 V appliances and of ACSs. Then, there is no risk of a spurious firing due to turn on in breakover mode.

But Figure 6 also shows that, despite overvoltages being limited, high dV/dt rates are still present. Indeed, the 500 V overvoltage is reached in less than 10 ns. Silicon devices must therefore feature a very high dV/dt capability to avoid parasitic turn-on. The next paragraph summarizes some comparative analysis made on triacs and ACSs.

Figure 5. Line to neutral voltage during 2 kV burst without mains filter

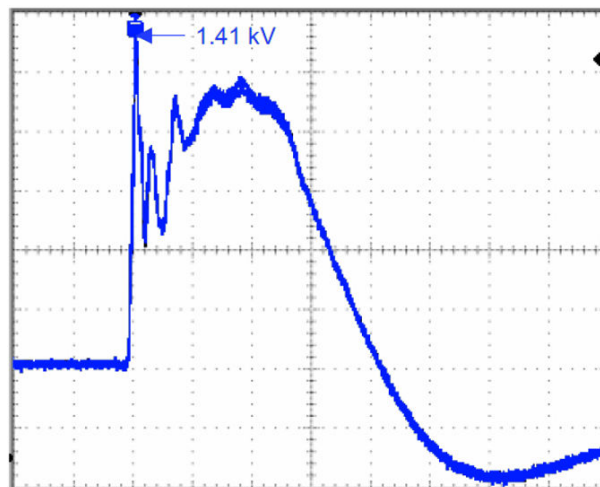
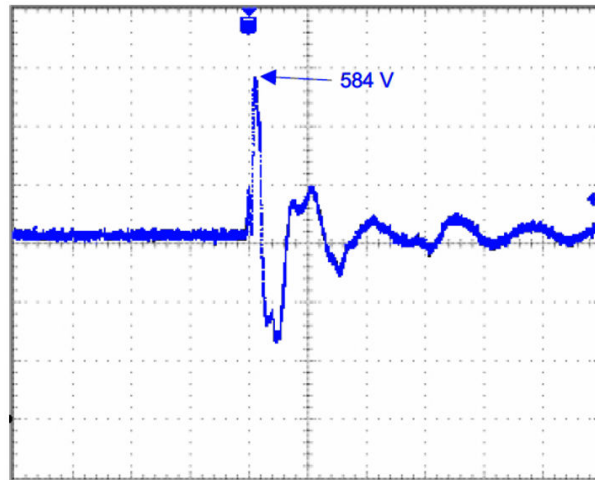

Figure 6. Line to neutral voltage during 2 kV burst with mains filter



2.2 ACS / Triac comparison

The tests are carried out in the following conditions:

- Printed circuit board 10 cm above reference plane
- A mains filter (as described in [Figure 7](#)) connected to the mains plug
- Board embeds four triacs (or ACSs)
- Each triac-A2 (or ACS-OUT) terminal is linked to a 25 W light bulb (resistive loads are chosen in order not to reduce dI/dt rates in case of firing)
- Each gate connected to A1 or COM terminals respectively, for triac and ACS, through a 470 ohm resistor (to be free of spurious firings coming from the microcontroller)
- No snubber circuits added across the triacs or ACSs
- Ambient temperature 25 °C
- Burst generator programmed as required in the IEC 61000-4-4 standard (15 ms burst duration, 3 Hz burst frequency, 5 kHz spike frequency, one second test duration).

Figure 7. Mains filter for IEC 61000-4-4 test

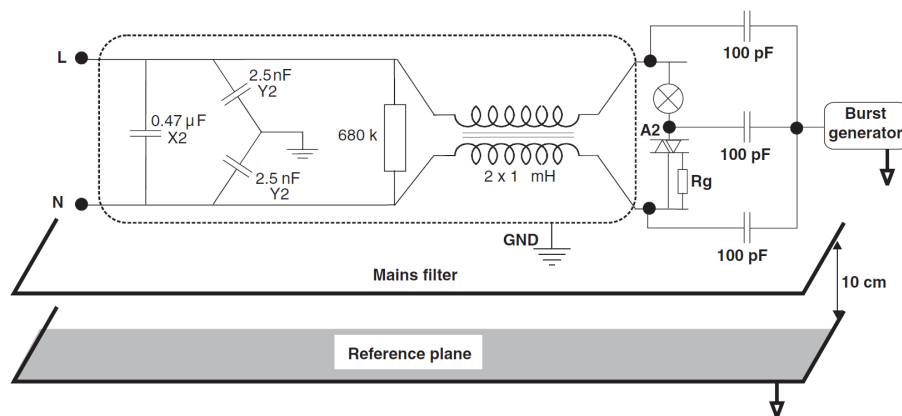

The high voltage output of the burst generator is connected:

- In the case of the “plug test”: to a 33 nF capacitor with its other terminal connected to L, N, ground, or several of these terminals (as required in the IEC 61000-4-4 standard)
- In the case of the “I/O test”: to six 100 pF discrete capacitors with their other terminals connected to the four A2 (or OUT), L, and N terminals (to simulate the coupling aluminum sheet).

A test is carried out for each coupling mode. The minimum burst level, which causes a spurious firing of one of the four devices, is measured. [Figure 8](#) gives the results of these tests.

Sensitive triacs and ACSs with identical gate currents were compared. For a 5 mA maximum gate current, Z0107MN triacs and ACS108-8TN devices were used. For a 10 mA maximum gate current, Z0109MN triacs and ACS108-8SP devices were used. All these components are in SMD packages SOT223-3L and SOT223-2L for the ACS108-8SP.

The different capability of these devices depends on the dV/dt characteristics. The device can switch on due to excessive dV/dt rates. For example, [Figure 9](#) shows that a Z0109MN turns on after a 17 kV/ μ s rate, due to a 2 kV burst coupled to the line in the “plug test” configuration. As for the maximum junction temperature, 5 mA and 10 mA sensitivity ACSs can sustain up to 300 V/ μ s and 500 V/ μ s respectively, whereas triacs of similar sensitivities only withstand 20 and 50 V/ μ s respectively, it is obvious that choosing ACSs improve the burst immunity of the electronic board.

“I/O tests” have also been carried out. The difference between triacs and ACSs is more difficult to prove as most of the devices sustain bursts higher than the maximum capacity of the used generator (4.5 kV). [Table 1](#) shows the results of these trials.

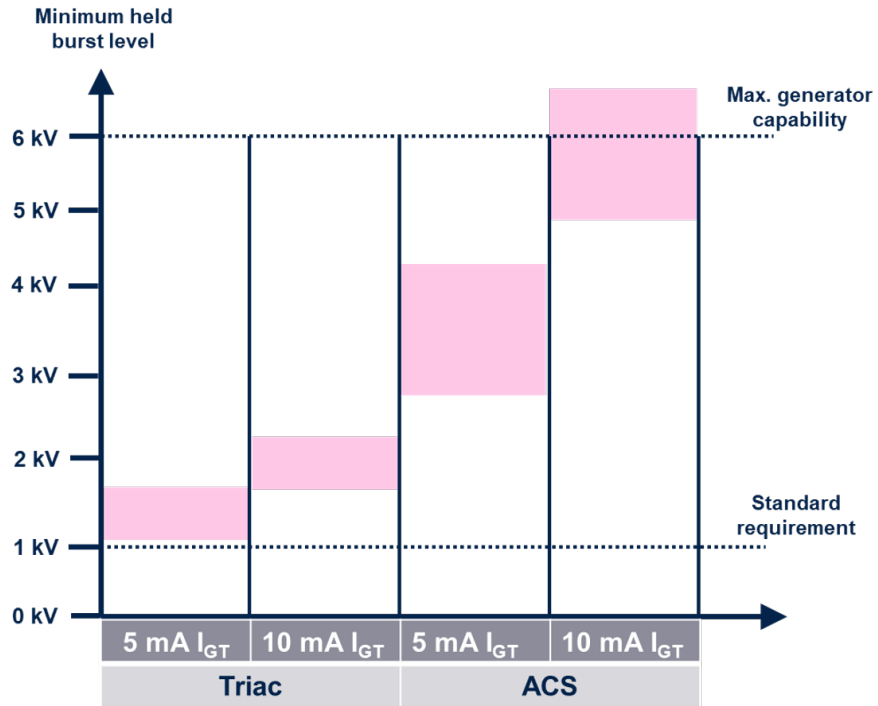
Figure 8. Minimum burst levels before turn-on for different devices

Table 1. Minimum burst levels before devices turn on for I/O tests

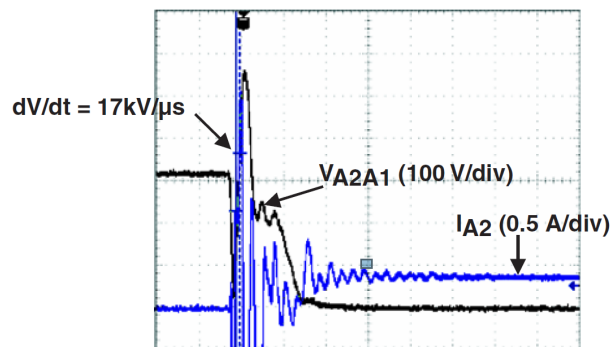
Device	Z0107MN	Z0109MN	ACS108-8TN	ACS108-8SP
Min. level capability	4 kV	> 4.5 kV	> 4.5 kV	> 4.5 kV

Figure 9. Spurious firing of a Z0109MN after a 2 kV burst

3 Conclusion

The IEC 61000-4-4 standard requires that for systems working on public power networks, the system must operate without any problem during burst voltages up to 1 kV. It has been shown that the mains filter, which is commonly added in washing machines to reduce the noise generated by universal motor brushes, triacs and ACSs of 5 mA sensitivity can pass the standard requirements. However, some manufacturers increase the burst level up to 2 kV. In this case, only ACSs fulfill the requirement without additional components. As for the triacs, they turn-on due to high dV/dt rates. An RC circuit must then be added to even out the dV/dt and designers must manage the following trade-off:

1. **Reduce dV/dt rates:** The snubber capacitance must be high and the snubber resistance must be low
2. **Reduce the dI/dt rate at turn-on:** The snubber capacitance must be low and the snubber resistance must be high. Along with the fact that these snubbers and the varistors are no longer required with ACSs, using ACS reduces design time and increases electronic board reliability.

Appendix A References

Table 2. reference name and description

Ref. name	Description
[1]	AN302 "Thyristors and Triacs: holding current - an important parameter",STMicroelectronics.
[2]	L.Gonthier, "A New Solid State Switch for Home Appliances", International Appliance Technical Conference, West Lafayette, Indiana (USA), May 1999
[3]	L.Gonthier, "A New Overvoltage-Protected Logic Level AC Switch Thanks to Functional Integration", European Conference on Power Electronics and Application (EPE'99), Lausanne (Switzerland), September 1999.

Revision history

Table 3. Document revision history

Date	Revision	Changes
June-2001	3	Previous issue.
24-Apr-2009	4	Reformatted to current standards. Full technical review for current products.
22-June-2010	5	Added trademark information in <i>Figure 1</i> .
20-Mar-2024	6	Updated Figure 2 , Section 1.2: IEC 61000-4-5 standard , Figure 3 , Figure 4 , Figure 5 , Figure 6 , Figure 8 , Table 1 , and Figure 9 . Minors text changes.

Contents

1	ACS: an overvoltage protected AC device	2
1.1	Inductive load switch-off	2
1.2	IEC 61000-4-5 standard	3
2	Fast transient immunity tests	5
2.1	Standard requirements and mains filter utility	5
2.2	ACS / Triac comparison	7
3	Conclusion	9
Appendix A References		10
Revision history		11
List of figures		13

List of figures

Figure 1.	ACS symbol description	1
Figure 2.	Valve turn-off - typical oscillogram with the AC108-8SP device	2
Figure 3.	2 kV surge on the mains	3
Figure 4.	ACS breakover	4
Figure 5.	Line to neutral voltage during 2 kV burst without mains filter	5
Figure 6.	Line to neutral voltage during 2 kV burst with mains filter	6
Figure 7.	Mains filter for IEC 61000-4-4 test	7
Figure 8.	Minimum burst levels before turn-on for different devices	8
Figure 9.	Spurious firing of a Z0109MN after a 2 kV burst	8

IMPORTANT NOTICE – READ CAREFULLY

STMicroelectronics NV and its subsidiaries (“ST”) reserve the right to make changes, corrections, enhancements, modifications, and improvements to ST products and/or to this document at any time without notice. Purchasers should obtain the latest relevant information on ST products before placing orders. ST products are sold pursuant to ST’s terms and conditions of sale in place at the time of order acknowledgment.

Purchasers are solely responsible for the choice, selection, and use of ST products and ST assumes no liability for application assistance or the design of purchasers’ products.

No license, express or implied, to any intellectual property right is granted by ST herein.

Resale of ST products with provisions different from the information set forth herein shall void any warranty granted by ST for such product.

ST and the ST logo are trademarks of ST. For additional information about ST trademarks, refer to www.st.com/trademarks. All other product or service names are the property of their respective owners.

Information in this document supersedes and replaces information previously supplied in any prior versions of this document.

© 2024 STMicroelectronics – All rights reserved