

### 5 W + 5 W dual BTL class-D audio amplifier demonstration board based on the TDA7491LP

## Introduction

The STEVAL-CCA029V1 is a demonstration board designed for the TDA7491LP dual BTL class-D audio amplifier. This application note provides the board specifications and a quick-start list for standalone operation. Also included are the schematic, printed circuit board layout and bill of material.

Due to its high efficiency, the device assembled in the PSSO36 (slug-down) package is capable of dissipating heat without any heatsink. Jumpers on the board allow the configuration of the amplifier in order to verify all the features as single-ended or differential inputs, fixed gain settings. Microswitches are also provided to enable the standby and mute functions.

The main features of the TDA7491LP include:

- 5 W +5 W continuous output power at THD =10%,  $R_L = 8 \Omega$ ,  $V_{CC} = 9 V$
- 5 W +5 W continuous output power at THD = 10%,  $R_L = 4 \Omega$ ,  $V_{CC} =6.5V$
- Wide-range, single-supply operation (5 V - 14 V)
- High efficiency ( $\eta = 90\%$ )
- Four selectable, fixed gain settings (20 dB, 26 dB, 30 dB and 32 dB)
- Differential inputs to minimize common-mode noise
- Filterless operation
- Standby and mute features
- Short-circuit and thermal overload protections
- Externally synchronizable

**Figure 1. STEVAL-CCA029V1**

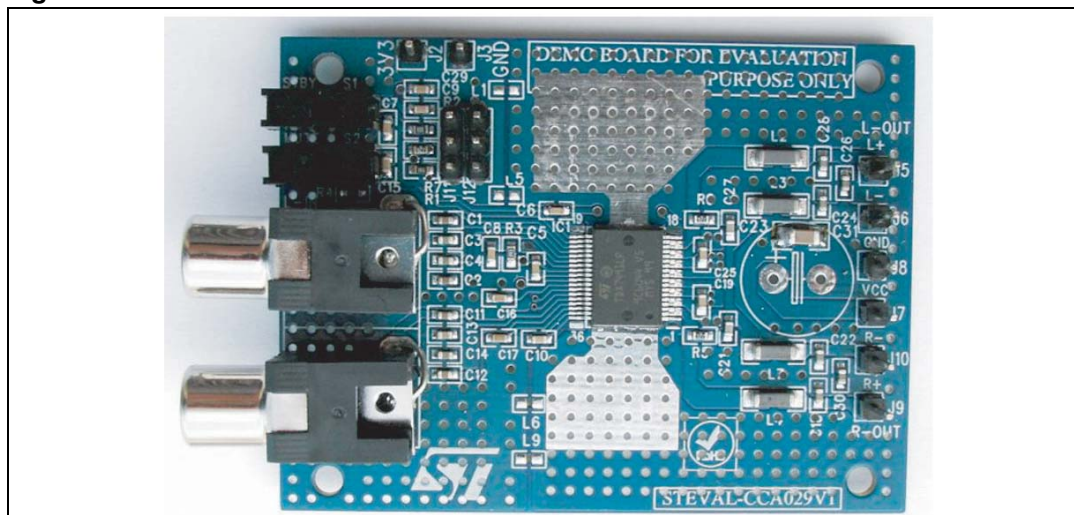

# Contents

- 1      Operation ..... 3**
  - 1.1    Power supply ..... 3
  - 1.2    Demonstration board preparation ..... 3
  - 1.3    Inputs and outputs ..... 3
  - 1.4    Powering up ..... 4
  - 1.5    Gain settings ..... 5
  - 1.6    Single-ended or differential input ..... 5
  - 1.7    Board schematic and bill of material ..... 6
  
- 2      PCB layout ..... 8**
  - 2.1    Layout views ..... 8
  - 2.2    Design guidelines for PCB schematic and layout ..... 9
    - 2.2.1    Dumping network ..... 9
    - 2.2.2    Filterless operation ..... 9
    - 2.2.3    Layout recommendations ..... 10
  
- 3      Revision history ..... 13**

# 1 Operation

The TDA7491LP demonstration board specifications are as follows:

- Power supply voltage range: 5 V to 14V
- Number of channels: 2 BTL (bridge-tied load) stereo
- Load impedance: 4  $\Omega$  to 8  $\Omega$
- Gain settings: 20 dB, 26 dB, 30 dB, 32 dB
- Undervoltage protection (UVP): 4 V

## 1.1 Power supply

A single power supply is required to feed the TDA7491LP demonstration board via the connector J2 (see [Figure 2](#)).

Connect the positive voltage of the 15 V/3 A DC power supply to the +Vcc pin and the negative to GND.

*Note:* Voltage range 5 V to 14 V = 3 A current capability

## 1.2 Demonstration board preparation

1. Ensure that the power supply is switched OFF.
2. Connect the regulated power supply, adjusted in the device operating range, to the connector J7(Vcc) - J8(GND) (observe the polarity).

## 1.3 Inputs and outputs

1. Connect the loads across the connectors J5-J6 (LEFT) and J9-J10 (RIGHT), the specified impedance ranges from 4 to 8  $\Omega$ .
2. Connect the analog audio inputs, single-ended, to the L-input and R-input RCA plugs (J1).

Refer to [Figure 2: Demonstration board connections on page 4](#).

Figure 2. Demonstration board connections

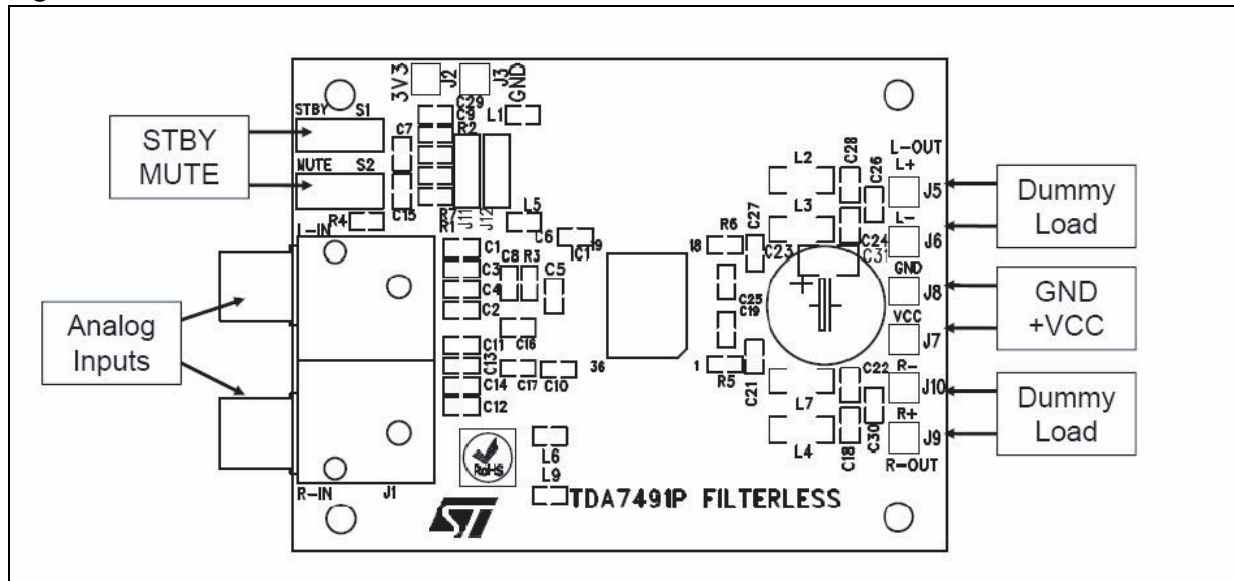

### 1.4 Powering up

Before powering up the demonstration board, ensure that the TDA7491LP is in standby and mute conditions and the gain is set to the desired value (default 20 dB). Verify also the dedicated switches and jumpers.

Table 1. Standby and mute settings

STBY (S1)	Mute (S2)	Status
L	L	STBY
L	H	STBY
H	L	MUTE
H	H	PLAY

Figure 3. Standby and mute switches

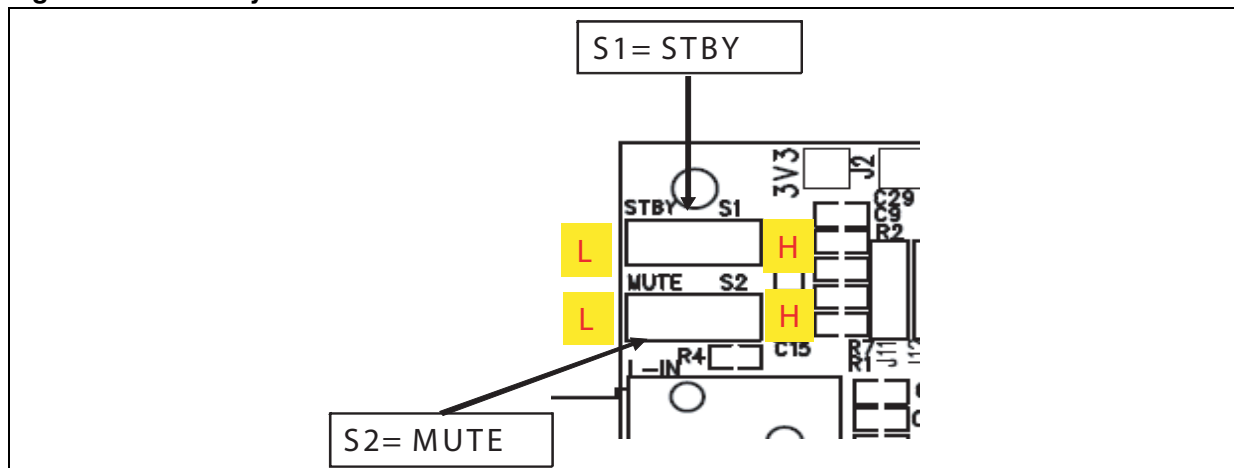

## 1.5 Gain settings

Table 2. Configuration of jumpers J11 and J12

Gain 0 (J11)	Gain 1 (J12)	Gain (db)
Open (L)	Open (L)	20
Open (L)	Closed (H)	26
Closed (H)	Open (L)	30
Closed (H)	Closed (H)	32

Figure 4. Jumpers J11 and J12

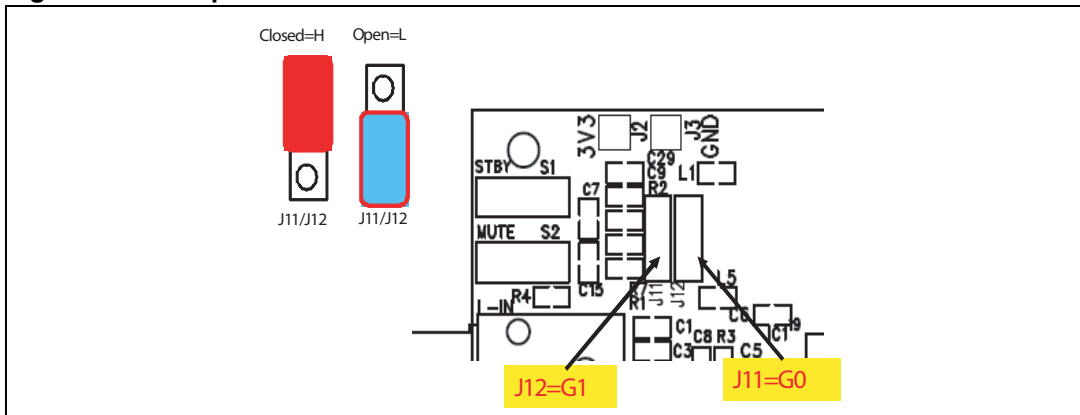

## 1.6 Single-ended or differential input

Although the TDA7491LP can be configured for both input configurations, the STEVAL-CCA029V1 allows only the single-ended connection.

# 1.7 Board schematic and bill of material

Figure 5. STEVAL-CCA029V1 schematic

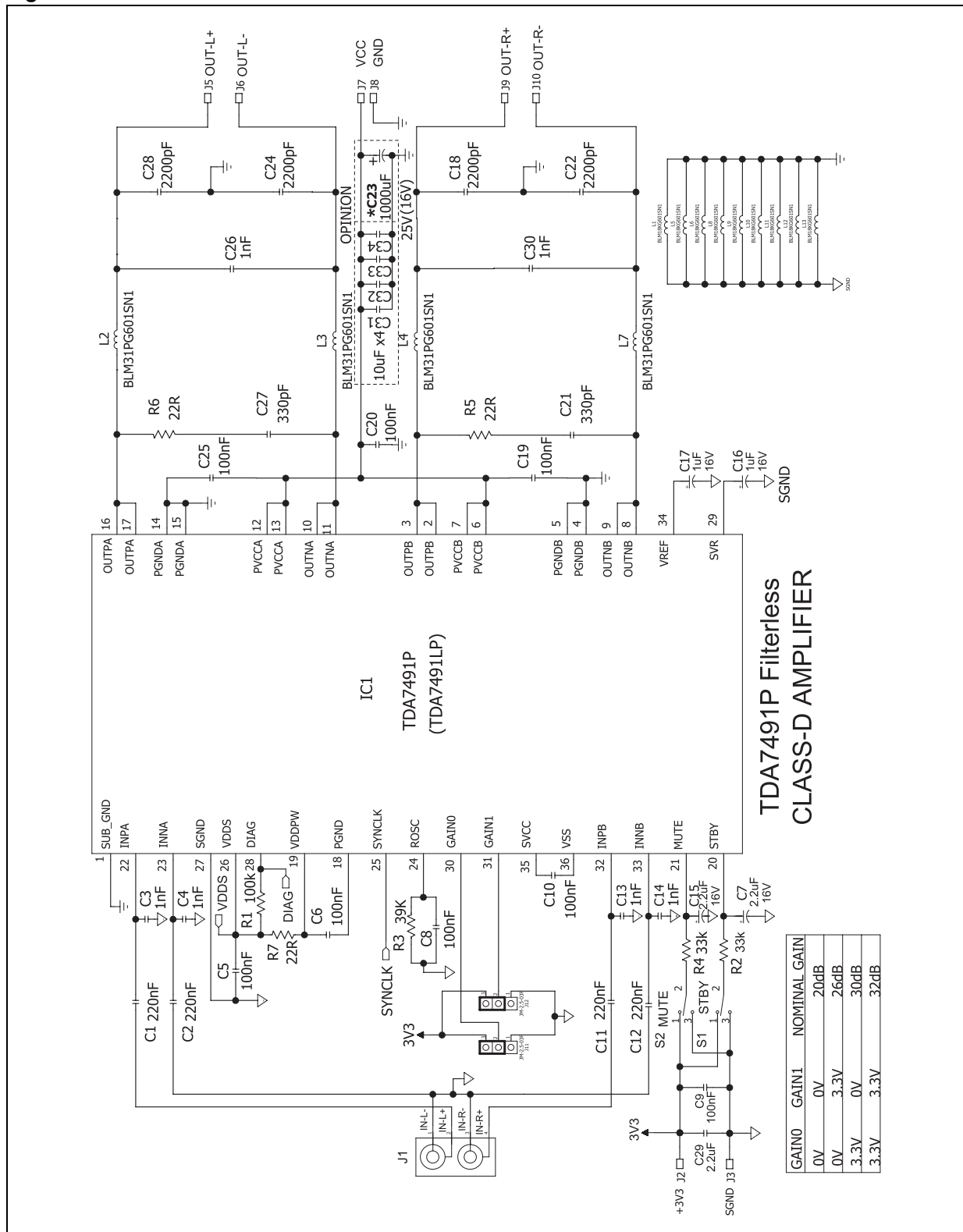

Table 3. Bill of material

Type	Footprint	Description	Qty	Reference	Manufacturer
CCAP	CAP0603	330 pF 50 V NPO $\pm 5\%$	2	C21, C27	Murata
CCAP	CAP0603	2200 pF 50 V X7R	4	C18, C22, C24, C28	Murata
CCAP	CAP0603	1 nF 50 V $\pm 10\%$	4	C3, C4, C13, C14	Murata
CCAP	CAP0603	100 nF 50 V $\pm 10\%$	7	C5, C6, C8, C9, C10, C19, C25	Murata
CCAP	CAP0603	220 nF 50 V $\pm 10\%$	4	C1, C2, C11, C12	Murata
CCAP	CAP0603	2.2 $\mu$ F, 16 V $\pm 10\%$	1	C29	Murata
ECAP	CAP0603	2.2 $\mu$ F, 16 V, $\pm 10\%$	2	C7, C15	Murata
ECAP	CAP0603	1 $\mu$ F, 16 V, $\pm 10\%$	2	C16, C17	Murata
ECAP	D < 12.0 mm	1000 $\mu$ F, 25 V, $\pm 10\%$ , pitch = 5.0 mm	1	C23	Rubicon
SMD tantalum	CAP1206	10 $\mu$ F, 25 V, $\pm 10\%$ , tantalum	4	C31, C32, C33, C34	Rubicon
RES	R0603	22 ohm, $\pm 10\%$ , 1/16 W	3	R5, R6, R7	Murata
RES	R0603	2.2k ohm, $\pm 10\%$ , 1/16 W	1	R8	Murata
RES	R0603	9.1k ohm, $\pm 10\%$ , 1/16 W	1	R13	Murata
RES	R0603	33k ohm, $\pm 10\%$ , 1/16 W	2	R2, R4	Murata
RES	R0603	39k ohm, $\pm 10\%$ , 1/16 W	1	R3	Murata
RES	R0603	100k ohm, $\pm 10\%$ , 1/16 W	1	R1	Murata
Terminal	Through-hole	2P, pitch = 5 mm connector terminal	3	J2, J3, J4	Any source
Jumper	2-way jumper	2P, pitch = 2.5 mm jumper	4	J5, J6, J8, J9	Any source
Switch	Slide	3P, pitch = 2.5 mm	2	S1, S2	Any source
Bead	SMD	0R	1	L1	Any source
Jumper	3-way jumper	3P, pitch = 2.5 mm jumper	2	J11, J12	Any source
IC	TDA7491LP	TDA7491LP (SSO36) slug-down	1	IC1	STMicroelectronics
Bead	SMD	BLM41PG471SN1	4	L2, L3, L4, L7	Murata
Connector	RCA-2P	RCA socket 2Px2, type AV2-8.4-12	1	J1	Songcheng
Regulator	TO92	L4931CZ33, 3V3 regulator	1	IC2	STMicroelectronics
PCB	75 x 50 mm	TDA7491P filterless PCB	1		King Brother

## 2 PCB layout

### 2.1 Layout views

Figure 6. Top view of PCB layout

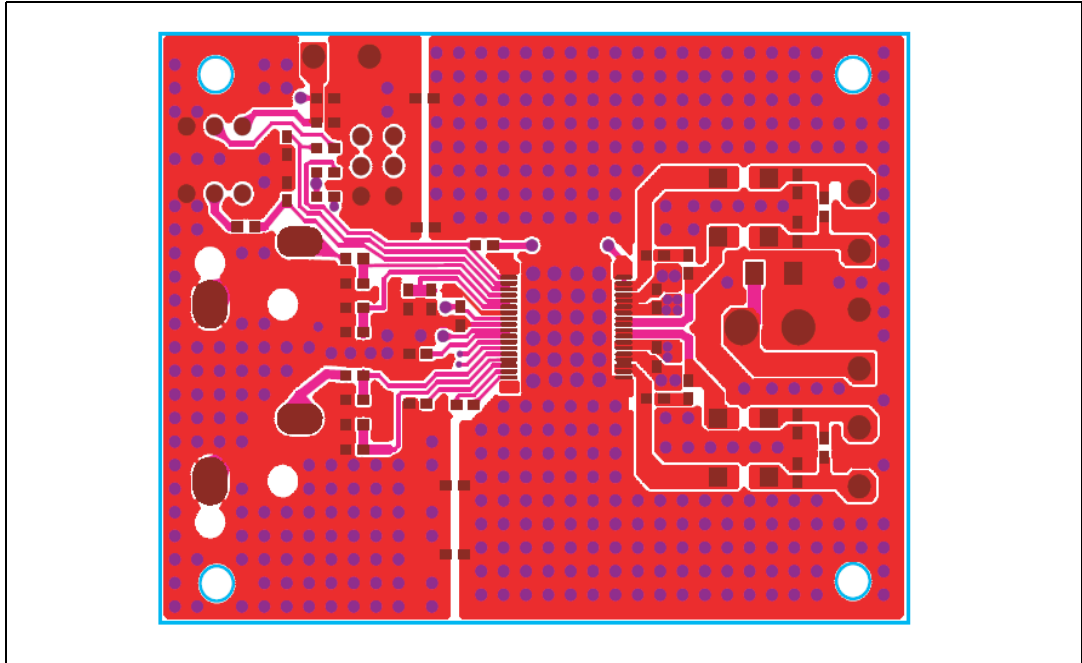

Figure 7. Bottom view of PCB layout

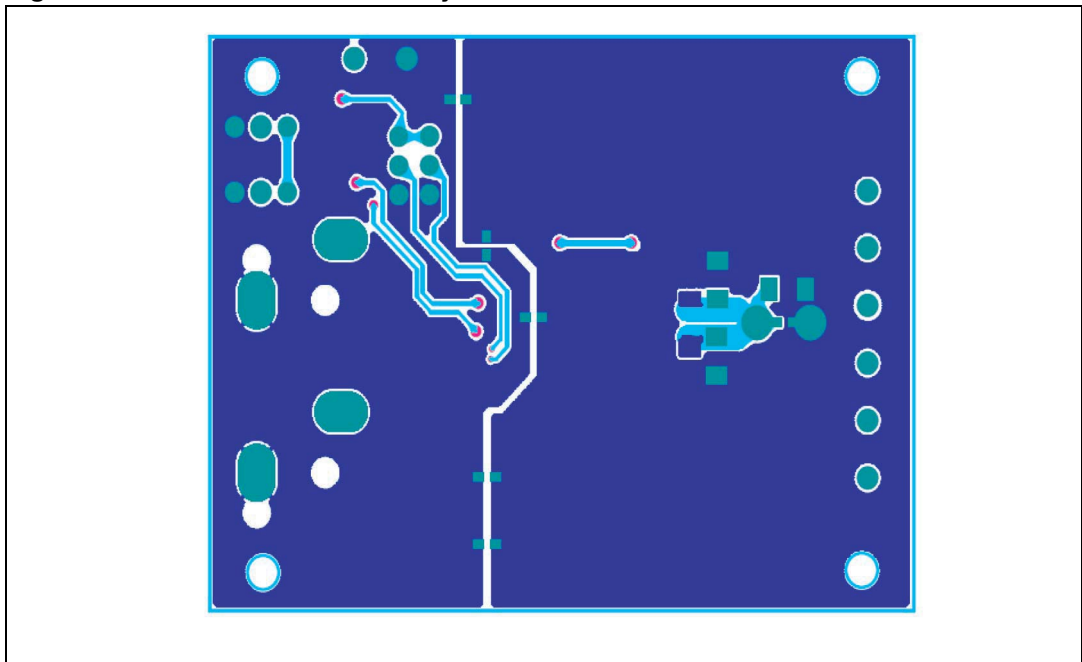
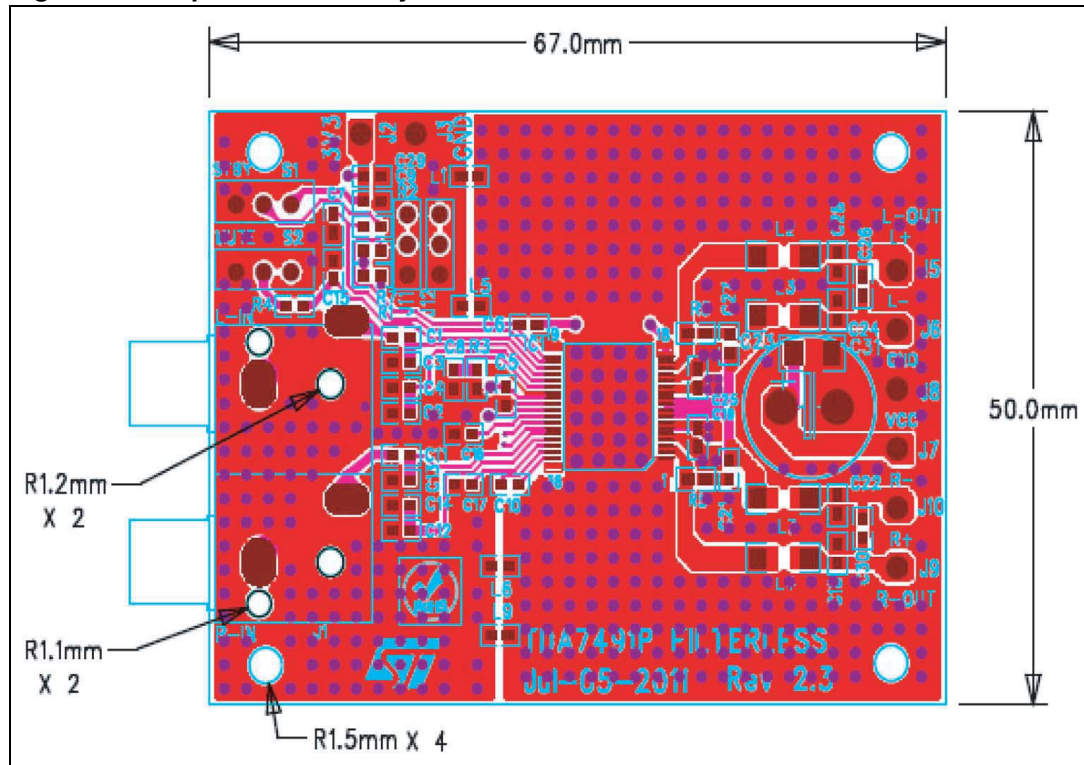



Figure 8. Top view of PCB layout - with dimensions



## 2.2 Design guidelines for PCB schematic and layout

### 2.2.1 Dumping network

The capacitor is mainly intended for high inductive loads and for common-mode noise attenuation.

Figure 9. Dumping network (for one channel)

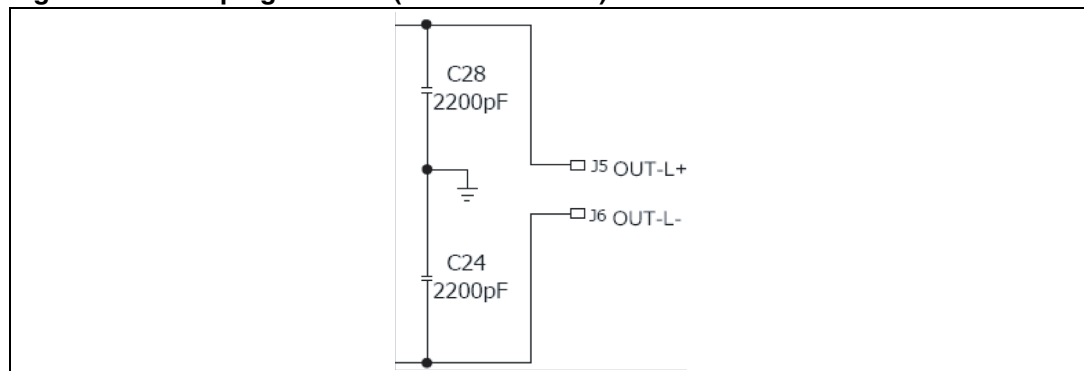

### 2.2.2 Filterless operation

The TDA7491LP can avoid using the main filter (LC Butterworth-based filter) if the speakers are placed at a distance within 50 cm. In order to improve the EMI performance ferrite beads are used (see [Figure 5](#) and [Table 3](#) for details).

### 2.2.3 Layout recommendations

The following figures illustrate layout recommendations.

Solder 100 nF bypass capacitors (X7R) as close as possible to the IC  $V_{CC}$  pins (recommended distance to be within 3 mm) in order to avoid spikes generated by the stray inductance caused by the copper supply lines.

**Figure 10. Capacitors soldered as close as possible to  $V_{CC}$  pins**

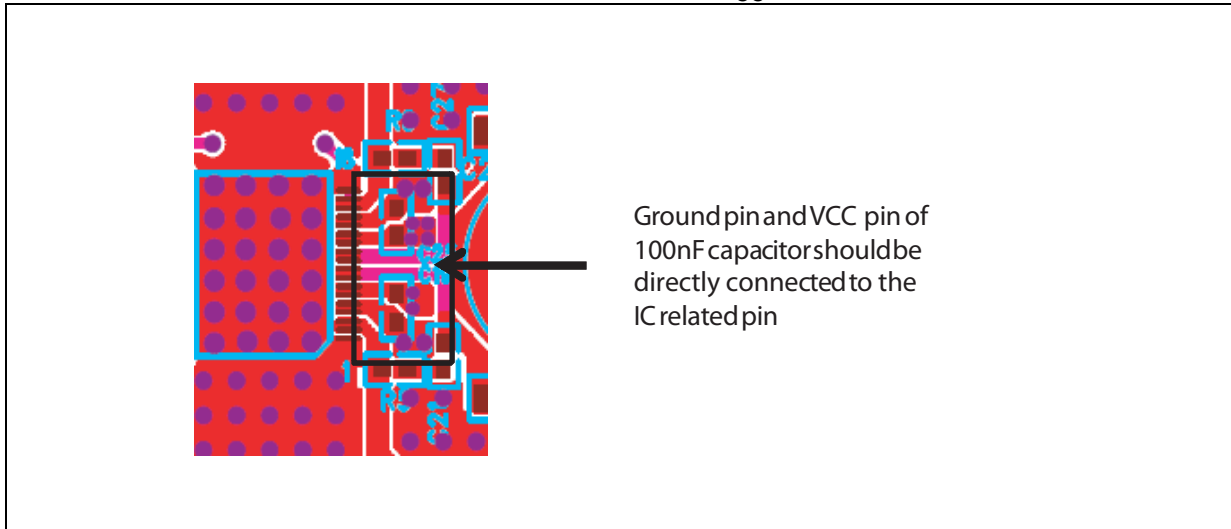

Solder the snubber networks as close as possible to the IC related pin.

A voltage spike dangerous for device operation could occur if the snubber network is far from the output pins. It is recommended that the distance between the snubber network and the output pins be within 5 mm.

**Figure 11. Snubber networks soldered as close as possible to relevant IC pin**

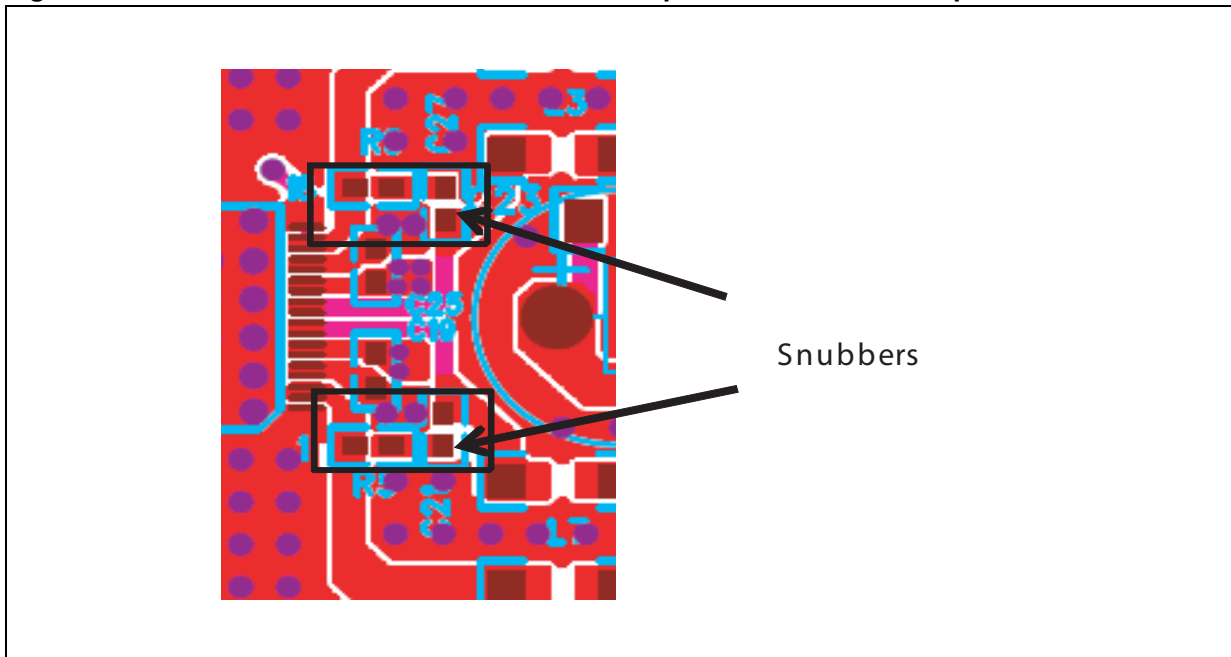

Put the RC filter for the ROSC pin close to the IC.

Figure 12. RC filter

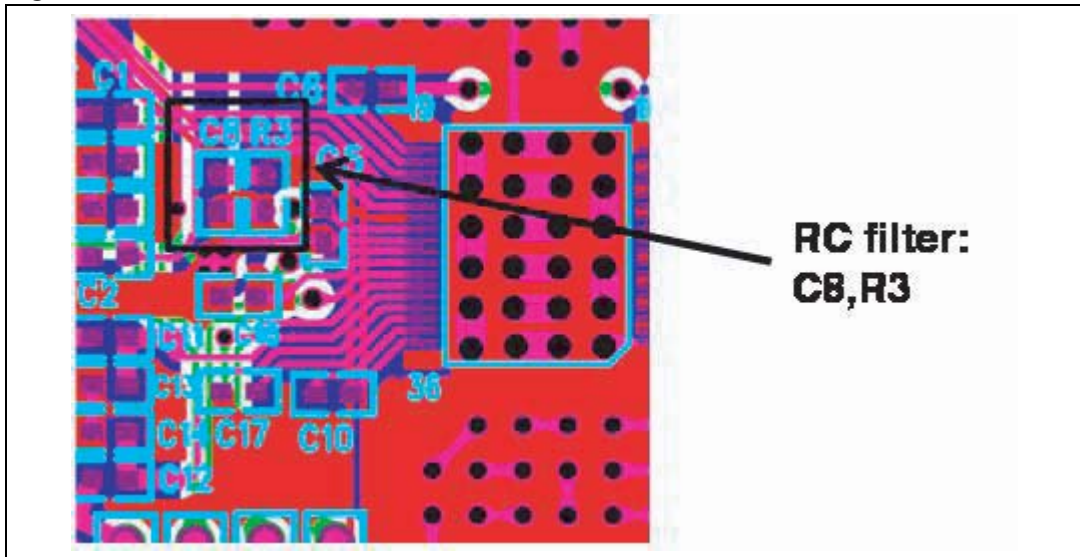

Put the filter capacitor for SVR, VREF, SVCC, VSS and VDDPW close to the IC.

Figure 13. Filter capacitor

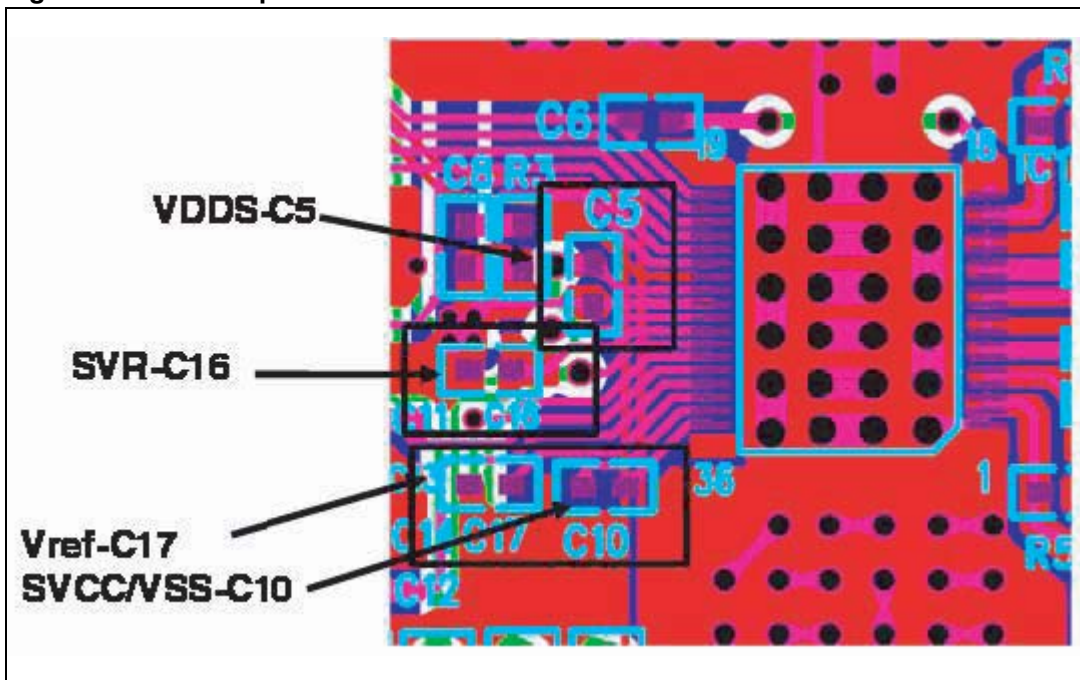

Signal ground should be directly connected to the negative terminal of the bulk capacitor.

Figure 14. Signal ground routing

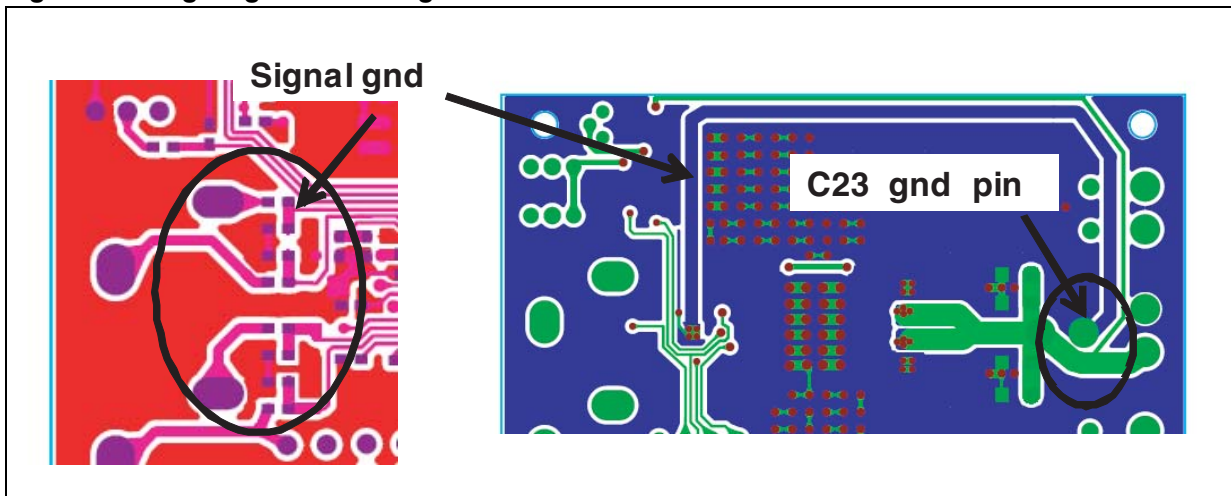

### 3 Revision history

Table 4. Document revision history

Date	Revision	Changes
21-Sep-2012	1	Initial release.

**Please Read Carefully:**

Information in this document is provided solely in connection with ST products. STMicroelectronics NV and its subsidiaries ("ST") reserve the right to make changes, corrections, modifications or improvements, to this document, and the products and services described herein at any time, without notice.

All ST products are sold pursuant to ST's terms and conditions of sale.

Purchasers are solely responsible for the choice, selection and use of the ST products and services described herein, and ST assumes no liability whatsoever relating to the choice, selection or use of the ST products and services described herein.

No license, express or implied, by estoppel or otherwise, to any intellectual property rights is granted under this document. If any part of this document refers to any third party products or services it shall not be deemed a license grant by ST for the use of such third party products or services, or any intellectual property contained therein or considered as a warranty covering the use in any manner whatsoever of such third party products or services or any intellectual property contained therein.

**UNLESS OTHERWISE SET FORTH IN ST'S TERMS AND CONDITIONS OF SALE ST DISCLAIMS ANY EXPRESS OR IMPLIED WARRANTY WITH RESPECT TO THE USE AND/OR SALE OF ST PRODUCTS INCLUDING WITHOUT LIMITATION IMPLIED WARRANTIES OF MERCHANTABILITY, FITNESS FOR A PARTICULAR PURPOSE (AND THEIR EQUIVALENTS UNDER THE LAWS OF ANY JURISDICTION), OR INFRINGEMENT OF ANY PATENT, COPYRIGHT OR OTHER INTELLECTUAL PROPERTY RIGHT.**

**UNLESS EXPRESSLY APPROVED IN WRITING BY TWO AUTHORIZED ST REPRESENTATIVES, ST PRODUCTS ARE NOT RECOMMENDED, AUTHORIZED OR WARRANTED FOR USE IN MILITARY, AIR CRAFT, SPACE, LIFE SAVING, OR LIFE SUSTAINING APPLICATIONS, NOR IN PRODUCTS OR SYSTEMS WHERE FAILURE OR MALFUNCTION MAY RESULT IN PERSONAL INJURY, DEATH, OR SEVERE PROPERTY OR ENVIRONMENTAL DAMAGE. ST PRODUCTS WHICH ARE NOT SPECIFIED AS "AUTOMOTIVE GRADE" MAY ONLY BE USED IN AUTOMOTIVE APPLICATIONS AT USER'S OWN RISK.**

Resale of ST products with provisions different from the statements and/or technical features set forth in this document shall immediately void any warranty granted by ST for the ST product or service described herein and shall not create or extend in any manner whatsoever, any liability of ST.

ST and the ST logo are trademarks or registered trademarks of ST in various countries.

Information in this document supersedes and replaces all information previously supplied.

The ST logo is a registered trademark of STMicroelectronics. All other names are the property of their respective owners.

© 2012 STMicroelectronics - All rights reserved

STMicroelectronics group of companies

Australia - Belgium - Brazil - Canada - China - Czech Republic - Finland - France - Germany - Hong Kong - India - Israel - Italy - Japan - Malaysia - Malta - Morocco - Philippines - Singapore - Spain - Sweden - Switzerland - United Kingdom - United States of America

[www.st.com](http://www.st.com)