

## How to design surface sensors for touch sensing applications on STM32 MCUs

### Introduction

This document describes the layout and mechanical design guidelines used for touch sensing applications with surface sensors. Capacitive sensing interfaces provide many advantages compared to mechanical user interfaces: modern look and feel, easy to clean, waterproof and robust.

Capacitive sensing interfaces are used in a wide range of applications. The interface is based on surface sensors made of small copper foils. The sensor acts as a capacitor that is alternatively charged and discharged. The capacitor value depends on the presence of the user's finger, as well as the sensor design. This application note introduces various sensor designs and recommendations to achieve optimum performance, keeping in mind that none of the sensor elements must interfere with each other.

This document provides guidelines on printed circuit board (PCB), overlay and panel materials plus all other items in the capacitive sensor environment.

**Table 1. Applicable products**

Type	Products series
Microcontrollers	<ul style="list-style-type: none"><li>• STM32F0 series, STM32F3 series</li><li>• STM32L0 series, STM32L1 series, STM32L4 series, STM32L4+ series, STM32L5 series</li><li>• STM32U0 series, STM32U5 series</li><li>• STM32WB series, STM32WBA series</li></ul>

## 1 Capacitive sensing technology

STMicroelectronics offers different capacitive sensing technologies for Arm-based STM32 microcontrollers. The technology covered by this application note is based on the charge transfer acquisition principle and is supported by all microcontrollers listed in [Table 1](#).

*Note:* Arm is a registered trademark of Arm Limited (or its subsidiaries) in the US and/or elsewhere.



### 1.1 Charge transfer acquisition principle

The surface charge transfer acquisition is a proven, robust and efficient way to measure a capacitance. It uses a minimum number of external components to operate with a single ended electrode type. This acquisition is designed around an analog I/O group that is composed of four GPIOs. Several analog I/O groups are available to allow the acquisition of several capacitive sensing channels simultaneously and to support a larger number of capacitive sensing channels. Within a same analog I/O group, the acquisition of the capacitive sensing channels is sequential.

One of the GPIOs is dedicated to the sampling capacitor ( $C_S$ ). Only one sampling capacitor I/O per analog I/O group must be enabled at a time.

The remaining GPIOs are dedicated to the electrodes and are commonly called channels. For some specific needs (such as proximity detection), it is possible to simultaneously enable more than one channel per analog I/O group.

The surface charge transfer acquisition principle consists of charging an electrode capacitance ( $C_X$ ) and transferring a part of the accumulated charge into a sampling capacitor ( $C_S$ ). This sequence is repeated until the voltage across  $C_S$  reaches a given threshold ( $V_{IH}$  in our case). The number of charge transfers required to reach the threshold is a direct representation of the size of the electrode capacitance. When the electrode is “touched”, the charge stored on the electrode is higher and the number of cycles needed to charge the sampling capacitor decreases.

## 1.2 Surface capacitance

A capacitance is modified when a finger gets close to a sensing electrode. The return path goes through one of the following paths:

- a capacitor through the user's feet
- a capacitor between the user's hand and the device
- a capacitor between the user's body and the application board through the air (like an antenna)

The figure below gives an overview of a system equivalent capacitances location.

**Figure 1. Equivalent touch sensing capacitances**

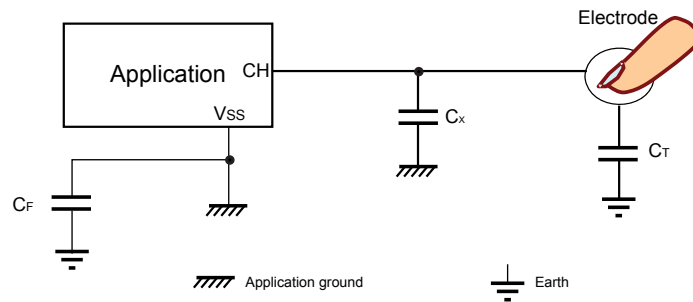

where the capacitances are the following:

- $C_X$  is the parasitic capacitance of the electrode.
- $C_X$  is composed of the two following capacitances:
  - The first one refers to earth, is not significant, and can be ignored.
  - The second one refers to the application ground and is dependent on the PCB or the board layout. This latter parasitic capacitance includes the GPIO pad capacitance and the coupling between the electrode tracks and the application ground. The PCB and board layout must be designed to minimize this parasitic capacitance.
- $C_F$  is the feedback capacitance between earth and the application. Its influence is important in surface capacitance touch sensing applications, especially for applications that do not feature a direct connection to earth.
- $C_T$  is the capacitance created by a finger touch. This capacitance is the source of the useful signal. Its reference is earth and not the application ground.

The total capacitance measured is a combination of  $C_X$ ,  $C_F$  and  $C_T$ , where only  $C_T$  is meaningful for the application. The total capacitance is given by the following formula:

$$C_X + \frac{1}{\frac{1}{C_T} + \frac{1}{C_F}}$$

## 2 Main capacitive sensing guidelines

### 2.1 Overview

A surface capacitive sensor is generally made up of the following different layers (see the figure below):

- a fiberglass PCB
- a set of electrodes made of a copper pad
- a panel made of glass, Plexiglas, or any non-conductive material
- a silk screen printing

Figure 2. Example of capacitive sensor construction

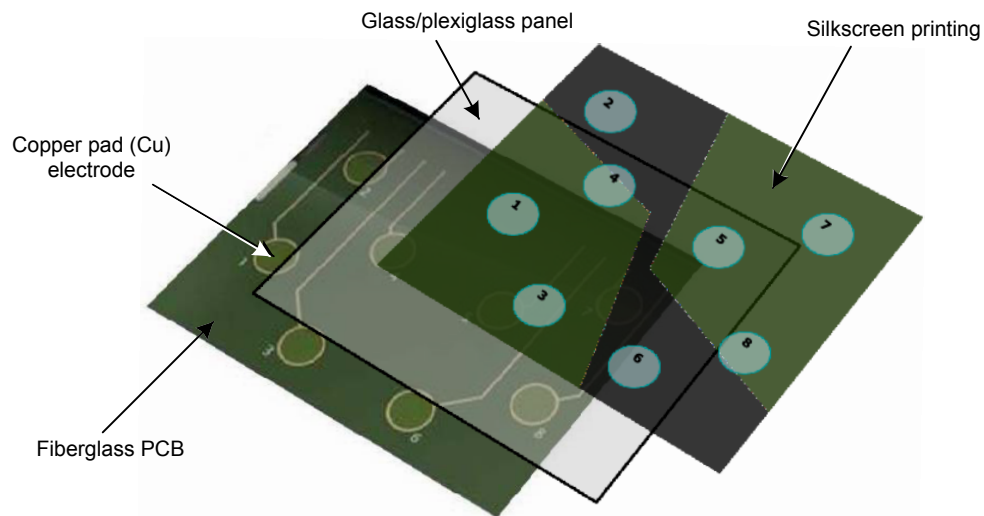

### 2.2 Construction

#### 2.2.1 Substrates

The substrate is the base material carrying the electrodes. A substrate can be chosen among any non-conductive material: in practice, PCB materials (such as FR4 or CEM-1), acrylics like polyethylene terephthalate (PET) or polycarbonate. Glass is also an excellent material for this purpose.

In many cases, the substrate used in electronic application works also well for capacitive sensing. Special care is required to avoid materials that can retain water contained in the atmosphere (e.g. hygroscopic material such as paper based). Unfortunately, this modifies  $\epsilon_R$  (relative permittivity) with environmental conditions.

It is not recommended to directly set the substrate against the front panel without gluing it by pressure or by bonding. Some moisture or air bubbles may appear between them and cause a change on the sensitivity. Closely link the substrate and the panel together avoids a varying sensitivity loss that is hard to predict (when the air bubbles are greater than 2 mm diameter).

The substrate and the panel can be strongly glue mechanically or with a suitable bonding material.

It is also possible to construct sensors that do not rely on a substrate (refer to [Section 2.2.7](#), [Section 3.5.3](#) and [Section 3.5.4](#)).

### 2.2.2 Electrode and interconnection materials

Generally, an electrode is made with the following materials: copper, carbon, silver ink, Orgacon™ or ITO (indium tin oxide).

The resistance to electric current of a material is measured in ohm-meters ( $\Omega\text{m}$ ). The lower this degree of resistivity the better, as well as a good RC time constant. That is why interconnections are made with low  $\Omega\text{m}$  material. A printed silver track at  $15.9\text{ n}\Omega\text{m}$  that is 100 mm long, 0.5 mm wide and 0.1 mm thick (so the area is  $0.05\text{ mm}^2$ ) has a resistance of  $32\text{ }\mu\Omega$ .

About metal deposition, another well-known approach is to consider the  $\Omega/\square$  (pronounced “Ohms per square” and called sheet resistance. Knowing this constant (given by the manufacturer) and how many squares are put in series, allows the evaluation of the overall resistance of the line).

For instance, silver and ITO (about 10 times greater) can be compared and the material well suited for the connections can be then identified (see the figures below).

**Figure 3. Clear ITO on PET with silver connections**

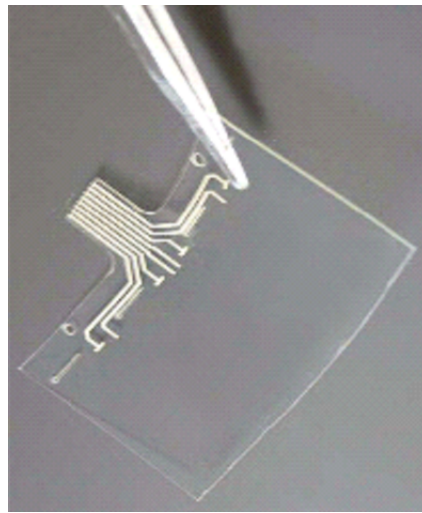

**Figure 4. Silver printing on PET**

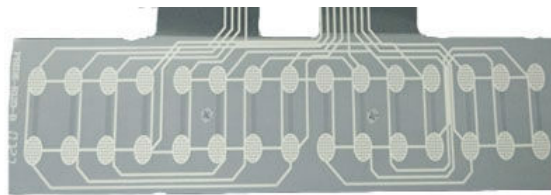

More and more applications need a flex PCB or FFC/FPC (flat flexible conductor/flexible printed circuit (see [Figure 5](#) and [Figure 6](#)) to interconnect circuitry. It is suitable if the overall application is mechanically stable. Furthermore, the FPC tracks are part of the touch sensor. If the flex moves a little bit, even a few micrometers, the capacitance to its surroundings definitely changes and may be significant, causing false touch detections or drops in sensitivity. Putting the flex in close proximity to a metal chassis or other signals, or on top of noisy circuitry, can cause problems as well (loss of sensitivity or spurious detection).

**Table 2. Potential application problems with flex PCB placement**

When the flex PCB is in close proximity to...	...the following can occur.
...the ground or to a metal chassis connected to the ground.	...the sensitivity is reduced.
... a floating metal object or to a floating metal chassis	... the object or the chassis conducts the touch to the electrode.
... a source of noise	... the acquisition is strongly perturbed and so the touchkey becomes non-usable.

Figure 5. Flexible PCB (FPC)



Figure 6. FR4 (2-sided epoxy-fiberglass)

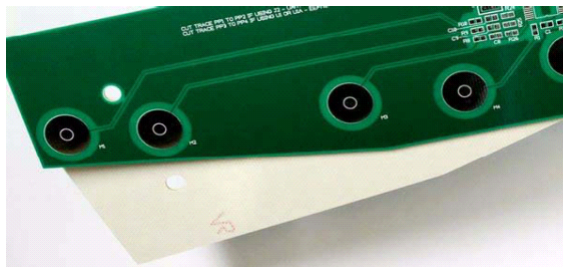

### 2.2.3

#### Panel materials

The panel material can be selected to suit the application. This panel material **must not** be conductive. The material characteristics impact the sensor performance, particularly the sensitivity.

#### Dielectric constant

The panel is the main item of the capacitor dielectric between the finger and the electrode. Its dielectric constant ( $\epsilon_R$ ) differentiates a material when placed in an electric field. The propagation of the electric field inside the material is given by this parameter. The higher the dielectric constant, the better the propagation.

Glass has a higher  $\epsilon_R$  than most plastics (see the table below). Higher numbers mean that the fields propagate through more effectively. A 5 mm panel with an  $\epsilon_R$  of height performs similarly in sensitivity to a 2.5 mm panel with a relative epsilon of four (all other factors being equal).

A plastic panel up to 2 mm thick can be used, depending on touchkey spacing and size. The circuit sensitivity must be adjusted during development to compensate for panel thickness, dielectric constant and electrode size.

The thicker a given material is, the worse the SNR. For this reason, it is always better to try and reduce the thickness of the front panel material. Materials with high relative dielectric constants are also preferable for front panels as they help to increase SNR.

**Table 3. Dielectric constants of common materials used in a panel construction**

Material	$\epsilon_R$
Air	1.00059
Glass	4 to 10
Sapphire glass	9 to 11
Mica	4 to 8
Nylon	3
Plexiglass	3.4
Polyethylene	2.2
Polystyrene	2.56
Polyethylene terephthalate (PET)	3.7
FR4 (fiberglass + epoxy)	4.2
PMMA (Poly methyl methacrylate)	2.6 to 4
Typical PSA	2.0 - 3.0 (approx.)

### Sensitivity

A useful parameter to consider with panel material and thickness (T) is the electric field equivalent vacuum thickness  $T_V$ , given by the following formula:

$$T_V = \frac{t}{\epsilon_R}$$

where t is the thickness of the dielectric.

$T_V$  is the thickness of vacuum with an electric field conduction equivalent to that of the material. The smaller it is, the easier the field can reach through. Panels with the same  $T_V$  make touchkeys with identical sensitivity. This works for both directions and may be used to evaluate the touch sensitivity from the back side of the application. For a panel built from a stack of different materials, it is possible to add the vacuum equivalent thickness of each layer as shown in the following formula:

$$T_{V(STACK)} = \sum T_{V(layers)}$$

Each material has an influence on the sensitivity. The equation can be used when, for example, the electrodes are on the bottom surface of the PCB substrate, then the thickness and  $\epsilon_R$  of the substrate are factors of the global sensitivity.

### 2.2.4 Mechanical construction and PCB to panel bonding

In order to ensure stable touch detection, the PCB must always be at the same place on the panel. The slightest variation, even as small as 100  $\mu\text{m}$ , may lead to differences in the signal that can be detected. This must be avoided to ensure the integrity of the touch detection.

The panel and other elements of the device must not be moved, or only as little as possible, by the user's finger. To avoid this kind of problem, glue, compression, co-convex surfaces can be used to mechanically stabilize the PCB and the panel very close together (using for example heat staking plastic posts, screws, ultrasonic welding, spring clips or non-conductive foam rubber pressing from behind).

Normal construction is to glue a sensor to a front panel with pressure sensitive adhesive (PSA). 3M467 or 468 PSAs work very well.

**Figure 7. Typical panel stack-up**

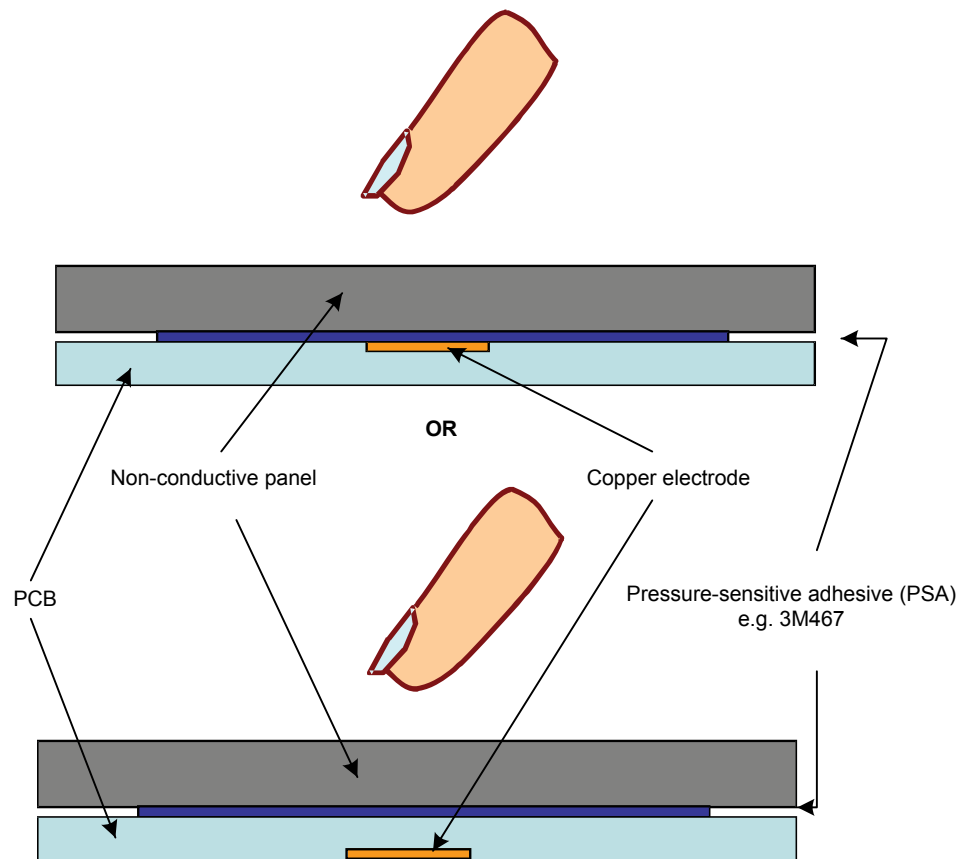

### 2.2.5 Metal chassis

A metal chassis behind a touch sensor is a good path to the ground and tends to reduce the sensitivity of the touch response in case there is a significant area of overlap. Such a metallic surface must never be electrically floating as it makes the whole product unstable in terms of touch detection. This is also applicable for any conductive decorative feature close to the sensor.

Metal chassis and decorative items must be grounded or connected to the driven shield (see [Section 3.5.2](#)) if it is implemented.

Metallic paints can be an issue if they contain conductive particles. Low particle density paint is recommended.

### 2.2.6 Air gap

Due to its dielectric constant, air can be used as an isolator. An air gap reduces the touch sensitivity when it is in the touch side stack. However, in some conditions, air can be useful to reduce the ground loading in the non-touch side stack. Such ground loading can be due to the metal chassis or an LCD. For instance, when designing a touch-screen solution, an air gap of 0.5 mm to 1 mm between the LCD and the touch sensor is recommended. Air gaps also help to reduce the sensitivity of the back side of a portable device.



### 2.2.7 Transfer of an electrode from PCB to the front panel

A conducting cylinder or a compressed spring can be used to achieve a transfer of an electrode from a PCB to the front panel (see [Section 3.5.3](#) and [Section 3.5.4](#)).

### 2.3 Placing of LEDs close to sensors

Light-emitting diodes (LEDs) are very often implemented near capacitive sensor buttons on application boards. LEDs are very useful for showing that the button has been correctly touched.

When designing application boards with LEDs, the following considerations must be taken into account:

- LEDs change capacitance when switched on and off
- A LED driver tracks can change impedance when switched on and off.
- The LED load current can affect the power rail.

Both sides of the LEDs must always follow the low-impedance path to ground (or power). Otherwise, LEDs must be bypassed by a capacitor to suppress the high impedance (typically 10 nF).

The examples of bypass capacitors for the LEDs using a driver (see the figure below) can also be applied to transistors.

**Figure 8. Examples of cases where a LED bypass capacitor is required**

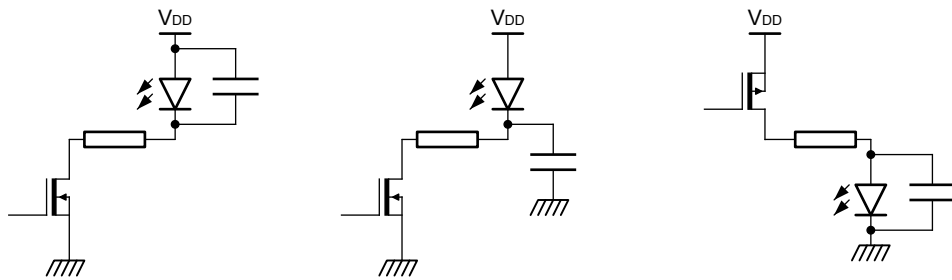

**Figure 9. Avoid to swap resistor and led**

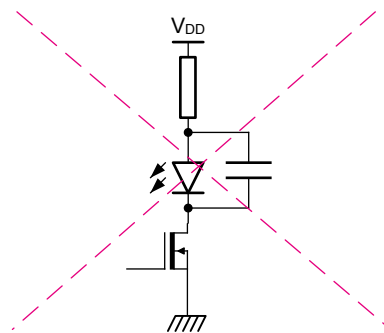

## 2.4 TC versus FT and TT I/Os

TC and FT I/O structures are slightly different:

- TC is a 3.6 V compliant I/O
- FT is a 5 V tolerant I/O
- TT is a 3 V compliant I/O

On a TC I/O, there is an internal clamping diode connected to  $V_{DD}$  (see the figure below).

Figure 10. TC I/O

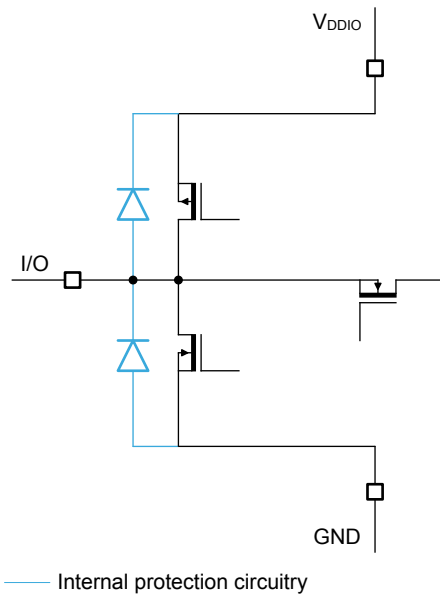

Thanks to this diode, when an EMC stress occurs, the level of the noise is clamped to  $V_{DD}$ . As a consequence, channels implemented on TC I/O show a better noise immunity.

With FT and TT I/Os, the same noise immunity level than with TC I/O can be reached by adding an external Schottky diode (see the figure below).

**Figure 11. FT and TT I/Os**

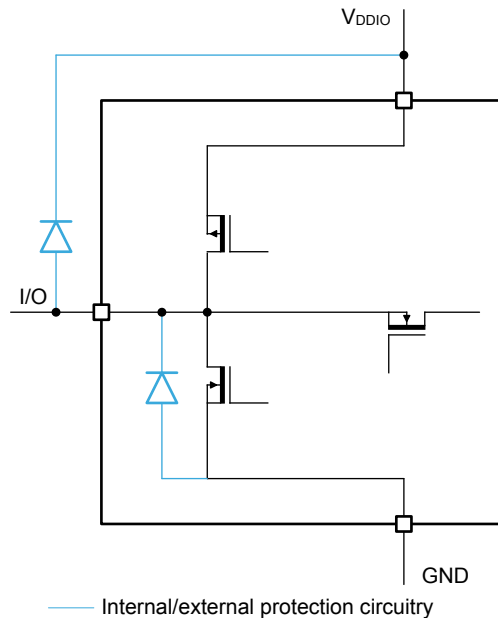

A Schottky diode with a low capacitance (< 5 pF) must be selected to secure the channel sensitivity reduction remains insignificant.

BAR 18 / BAS70-04 06 (C<sub>max</sub> = 2 pF) is a recommended STMicroelectronics Schottky diode.

This configuration is recommend in all cases (TC, FT or TT I/Os) to improve system conducted noise robustness.

## 2.5 Power supply

For devices without a touch sensing dedicated regulator, it is strongly recommended to use an external voltage regulator to power the device only.

The voltage regulator must be chosen to provide a stable voltage without any ripple. The actual precision of the voltage is not important, but the noise rejection feature is critical. This voltage is used to drive C<sub>X</sub> and is also used as a reference when measuring the sampling capacitor (C<sub>S</sub>). Any variation of this voltage may induce measurement variations that may generate a false touch or a missed touch. For instance, a ±10 mV peak to peak variation on V<sub>DD</sub> limits the resolution of linear sensor or rotary sensor to 4 or 5 bits.

The voltage regulator must be placed as far as possible from the sensors and their tracks.

The voltage regulator also acts as a filter against noise coming from the power supply. It is recommended to power any switching components, such as LEDs, directly from  $V_{DD}$  and not from the regulated voltage (see the figure below).

**Figure 12. Typical power supply schematic**

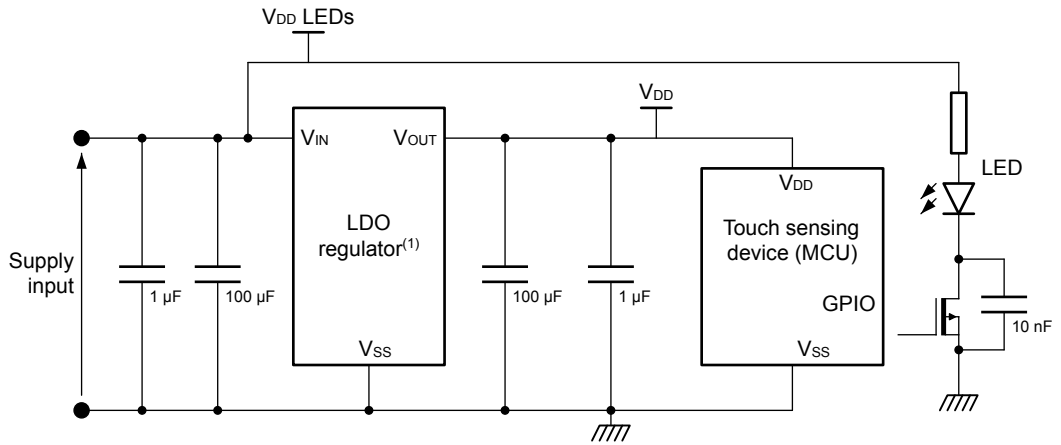

1) Typical voltage regulator LD2980 can be used.

## 3 Surface sensor design

### 3.1 Touchkey sensor

A touchkey can be either touched or untouched by the user. The information managed by the microcontroller is a binary one (0 for untouched and 1 for touched).

The sensor can be any shape. However, it is recommended to use round or oval as these shapes are the simplest. The libraries and hardware cells automatically compensate for capacitance differences, but the acquisition time and processing parameters can be optimized if the electrodes have similar capacitance. It is then recommended to use the same shape for all electrodes. The touchkeys can be customized by the drawing on the panel.

When designing touchkey sensors, the two following parameters must be considered:

- the object size to be detected
- the panel thickness

Regarding object size, it is recommended to design a sensor in the same range as the object to be detected. In most cases, it is a finger (see the figure below).

Figure 13. Sensor size



Regarding panel thickness, the touchkey must be at least four times as wide as the panel is thick. For example, a panel that is 1.5 mm thick and has no immediately adjacent ground layer, must have a touchkey sensor at least 6 mm in diameter if the touchkey sensor is round, or with a 6 mm side if the touchkey sensor is square (see the figure below). There are sensitivity issues if dimensions lower than these values are used.

Figure 14. Recommended electrode size



As shown in the equation below, a capacitor is used to detect the finger touch.

$$C_T = \frac{A \epsilon_R \epsilon_0}{d}$$

where:

- $C_T$  is the touchkey capacitance.
- $A$  is the area with regard to the electrode and the conductive object.
- $d$  is the distance between the electrode and the conductive object (usually the panel thickness).
- $\epsilon_R$  is the dielectric relative permittivity.
- $\epsilon_0$  is the vacuum permittivity.

The capacitor is proportional to the size of the electrode. Increasing the electrode area allows the capacitor to be maximized, but increasing the electrode size above the size of a finger touch only increases the parasitic capacitance and not the finger touch capacitance, resulting in lower relative sensitivity. (refer to [Section 3.5.4](#)).

There is also a problem of relative sensitivity: when the electrode size is increased,  $C_T$  stops increasing while  $C_X$  keeps growing. This is because the parasitic capacitance is directly proportional to the electrode area.

### 3.2 Touchkey matrix sensor

To extend the number of touchkeys, the touchkey can be implemented using a matrix arrangement (see the figure below). Refer to the application note *Increase the number of touchkeys for touch sensing applications on MCUs* (AN3236) for more details.

Figure 15. Simple matrix implementation

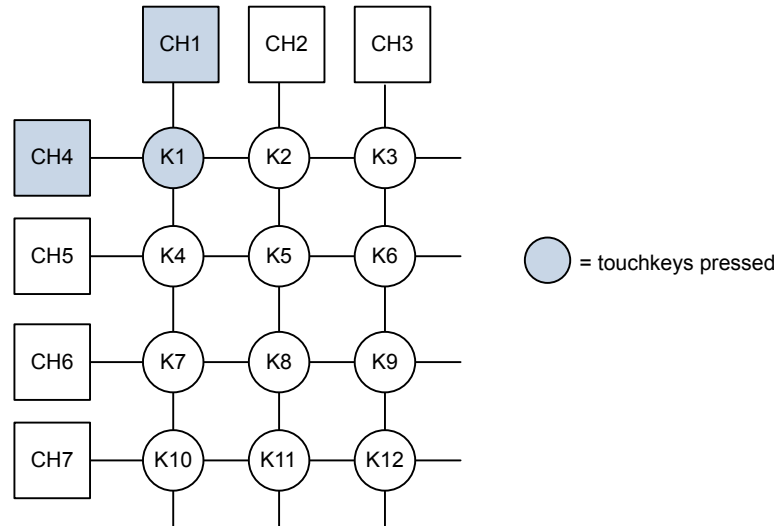

Some hardware recommendations are listed below:

- Touching one touchkey may induce sufficient capacitance change on other channels.
- Avoid imbalanced electrodes.
- Avoid column and line electrodes tracks too close in the user touchable area.

### 3.3 Linear sensor

A linear sensor is a set of contiguous capacitive electrodes connected to the device and placed in a single axis line. The number of electrodes depends on the desired size and resolution of the sensor.

The electrodes can be arranged in the three following different ways:

- Mono electrodes design: each channel is associated to only one electrode (see the figure below).

Figure 16. Mono electrodes design



- Half-ended electrodes design: the first and the last electrodes are connected to the same channel (usually the first one) and their width is half the width of the other electrodes. This is to ensure that all the electrodes capacitance are identical (see the figure below).

Figure 17. Half-ended electrodes design



- Dual electrodes design: all the electrodes are duplicated and interlaced together (see the figure below).

Figure 18. Dual electrodes design



The half-ended and dual electrodes designs are used to increased the touch area of the sensor. On top of that, there are two manners to design the electrodes pattern on the PCB:

- Normal pattern (see Figure 19)
- Interlaced pattern (see Figure 20)

These two patterns are described in more details in the next sections.

*Note:* For optimum performance of a linear or rotary sensor, all channels of such a sensor must be acquired simultaneously. Therefore, selected I/Os must belong to different analog I/O groups. Refer to the product datasheet for more information regarding I/O groups and available capacitive sensing GPIOs.

### 3.3.1 Normal patterned linear sensor

With a normal patterned half-ended linear sensor, the linearity is limited due to the ratio square width versus finger touch area (see the figure below).

Figure 19. Normal patterned linear sensor (5 channels/6 half-ended electrodes design electrodes)

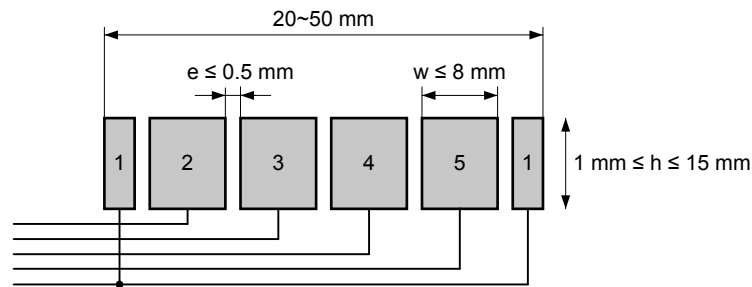

*Note:*  $e$  is the gap between two sensor electrodes,  $h$  is the height of the sensor electrode and  $w$  is the width of the sensor electrode.

To improve the linearity, to get a smoother transition between items and to increase the resolution, it is recommended to use an interlaced patterned electrodes design with crisscross teeth as shown in Figure 20. The size of the square electrode and gap between electrodes are valid irrespective of the number of electrodes. To get larger linear sensors, the number of electrodes can be increased to eight.

### 3.3.2 Interlaced patterned linear sensor

When using the charge transfer acquisition principle, it is possible to use only three channels thanks to the higher resolution achieved.

**Figure 20. Interlaced linear touch sensor (3 channels/4 half-ended electrodes design electrodes)**

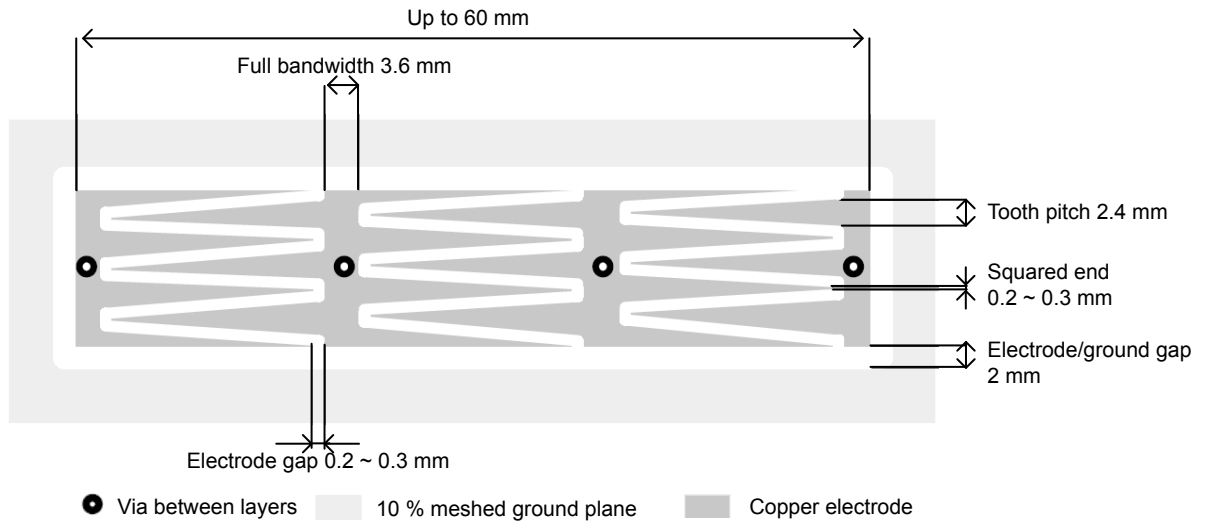

Note: The teeth of the interlaced linear touch sensor must be perfectly regular.

### 3.4 Rotary sensor

A rotary sensor is a set of contiguous capacitive electrodes connected to the device and placed in a circular way. The number of electrodes depends on the size and the resolution of the sensor.

The electrodes can be arranged in one of the two following ways:

- mono electrode design (same as the half-ended electrode design)
- dual electrode design

Like for the linear sensor, there are two options for designing the electrode pattern on the PCB:

- normal pattern
- interlaced pattern

These two patterns are described in more details in the next sections. A rotary sensor can also have a touchkey placed in the center.

**Note:** For optimum performance of a linear or rotary sensor, all channels of such a sensor must be acquired simultaneously, therefore selected I/Os must belong to different analog I/O groups. Refer to the product datasheet for more information regarding I/O groups and available capacitive sensing GPIOs.



### 3.4.1 Normal patterned rotary sensor

The figure below shows an example of a normal patterned rotary sensor.

**Figure 21. Normal patterned rotary sensor (3 channels/3 electrodes)**

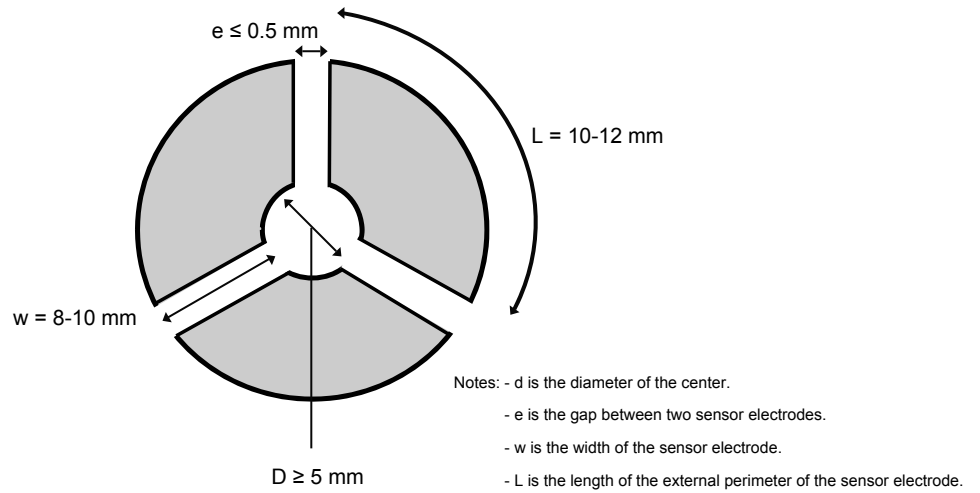

The dimensions  $d$ ,  $e$ ,  $w$ , and  $L$  of the three-electrode scheme above can also be applied for five and eight electrodes, thus giving a bigger rotor.

### 3.4.2 Interlaced patterned rotary sensors

Like for the linear sensor, the size of the rotary sensor can be increased by using the interlaced pattern design. This allows a smoother transition and a higher sensitivity.

To cover a large range of sizes, more teeth are added inside the rotary touch sensor rather than increasing the size of an individual tooth (see the figure below).

**Figure 22. Interlaced patterned rotary sensor (3 channels/3 electrodes)**

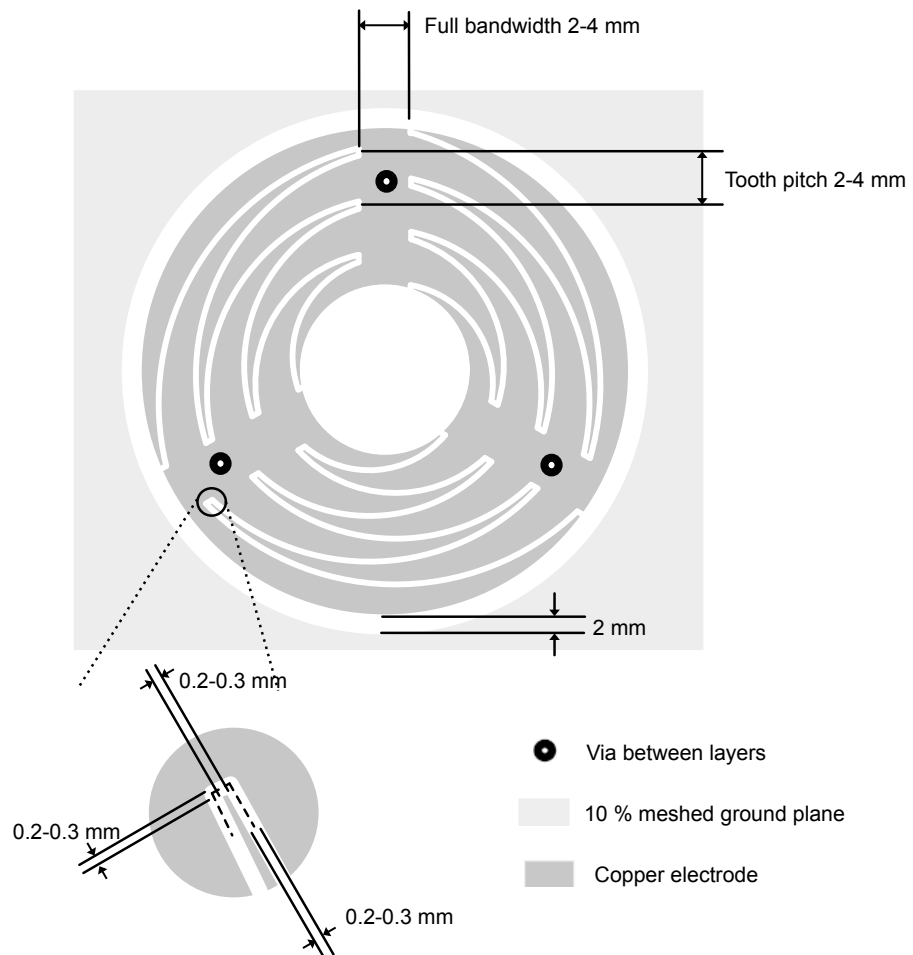

### 3.4.3 Rotary sensor with central touchkey

A touchkey can be located in the center of a rotary sensor. This touchkey has a lower sensitivity compared to other single touchkeys. To reduce the loss of sensitivity induced by the center touchkey on the rotary sensor, it is recommended to place the center touchkey and rotary sensor electrodes on the same acquisition bank. The pattern of the central touchkey must be as symmetrical as possible so that the loading effect on the rotary sensor is also symmetrical.

### 3.5 Specific recommendations

#### 3.5.1 LEDs and sensors

In some cases, a hole must be inserted in the sensor electrode to create a back-lighting touchkey (see the figures below). This is a very common solution that does not involve a sensitivity dip in the middle of the sensor electrode as the electric field tends to close over above the hole. As the sensor area decreases, there is a corresponding decrease in sensitivity.

Figure 23. Back-lighting touchkey

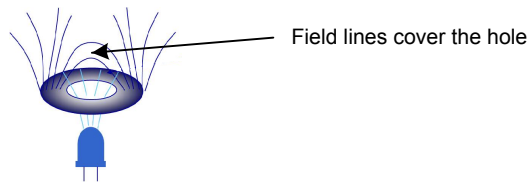

Figure 24. PCB 3D top view

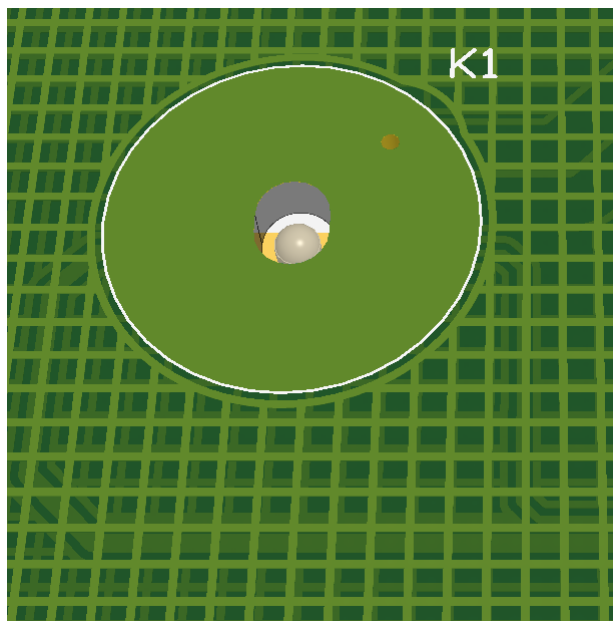
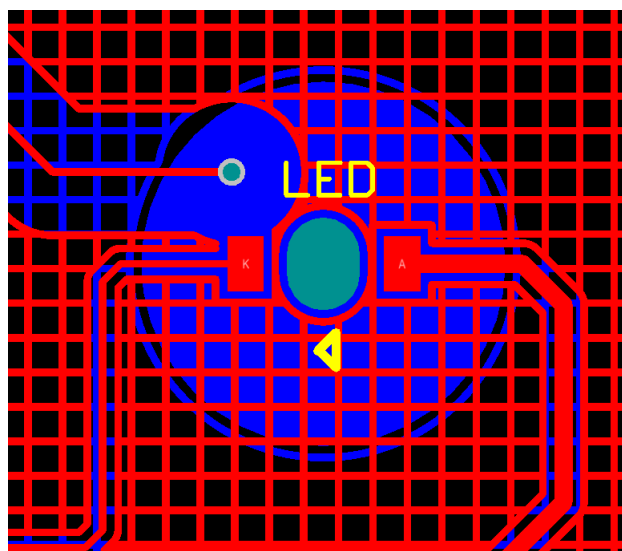

Figure 25. PCB bottom view



### 3.5.2 Driven shield

The principle of a driven shield is to drive the shield plane with the same signal as the electrode. Using a driven shield instead of a grounded shield brings the following advantages:

- The parasitic capacitance between the electrode and the shield no longer needs to be charged. This cancels the effect on the sensitivity.
- A driven shield is useful for certain applications where shielding may be required for the reasons listed below:
  - to protect the touch electrodes from a noise source
  - to remove touch sensitivity from the cable or track between the electrode and the sensing MCU
  - to increase the system stability and performance when a moving metal part is close to the electrode

If the design uses the charge transfer acquisition principle to have an efficient shield, its waveform must be similar to the one of the touchkey.

The following guidelines are important to achieve this (see [Figure 26](#)):

- The  $C_S/C_X$  of the shield must be in the same range as the  $C_S/C_X$  of the touchkeys.
- Using  $C_{S\text{shield}} = k \times C_{S\text{key}}$ , with  $k = (\text{shield area})/(\text{electrode area})$ , usually gives good results.
- The  $C_S$  of the shield does not need to be a high grade capacitor. Any type works.
- The noise/ESD protection resistor may be mandatory on the shield because it may be exposed to ESD. In order not to modify the pulse timings, the  $R_{S\text{shield}}$  must be in the range of  $R_{S\text{key}}/k$ .

Figure 26. STM32L driven shield example using the charge-transfer acquisition principle

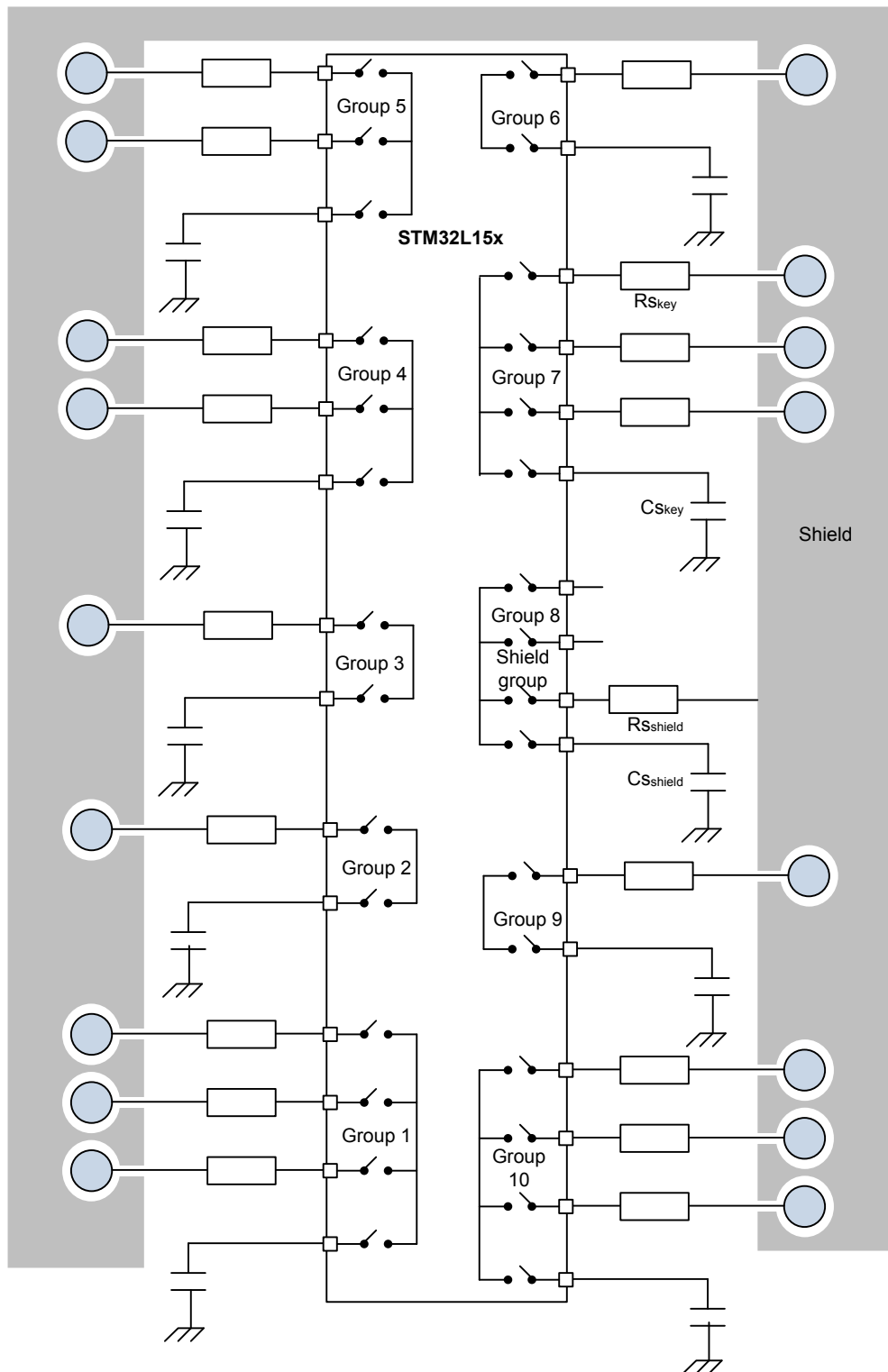

### 3.5.3 Using electrodes separated from the PCB

Surface electrodes can be used as they create a sensitive area on the bottom surface of the panel and are not close to the PCB.

One option is to print an electrode array on the inner surface of the front panel, with electrode shape rules as described in Section 3.1 and materials as described in Section 2.2.2. The sensors can be connected using spring contacts, conductive foam or rubber, or a flex tail attached using ACF/ACP (anisotropic conductive film/anisotropic conductive past) as shown in the figures below.

Figure 27. Printed electrode method showing several connection methods

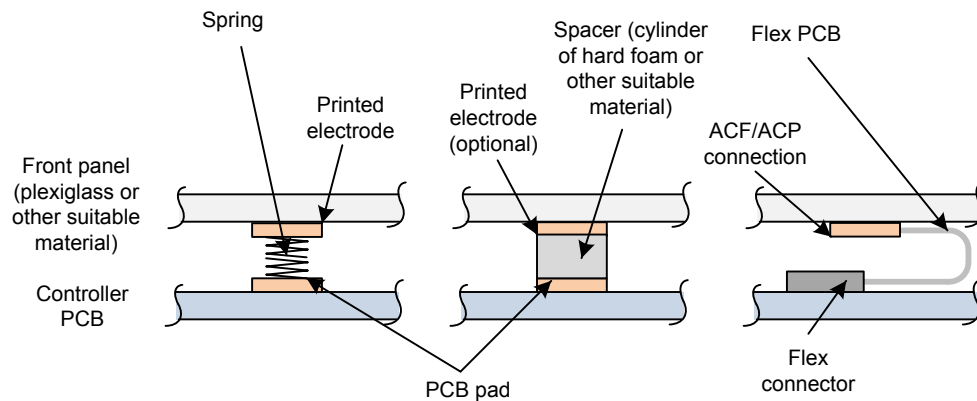
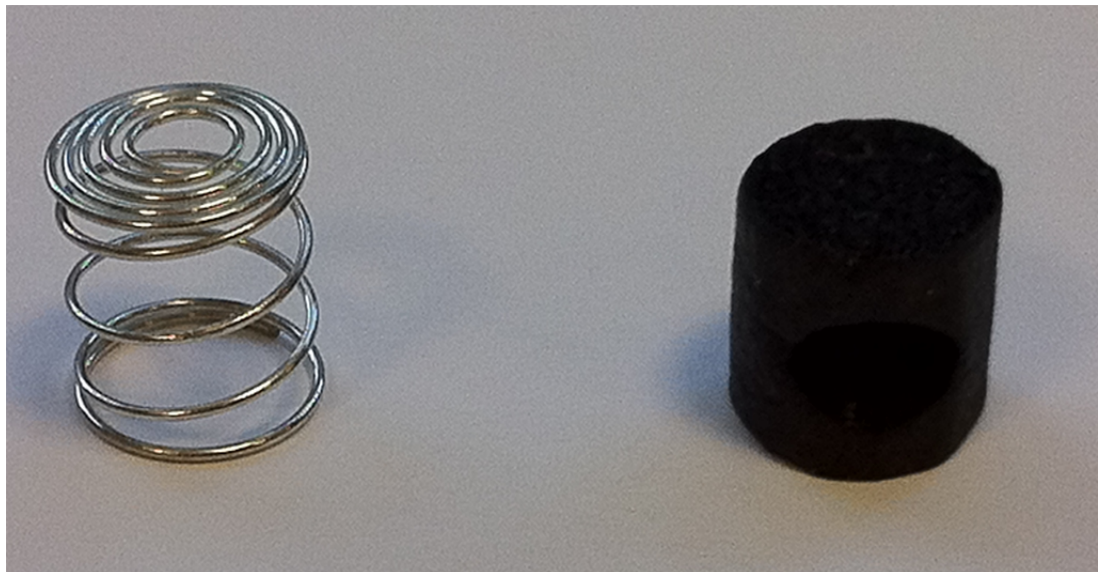

Figure 28. Spring and foam picture (both are not compressed)



With this technique, the area where the interconnection is made is touch-sensitive too.

### 3.5.4 PCB and layout

#### Sensor track length and width

The parasitic capacitance of a track depends on its length and width. Besides that, a long track can create an antenna effect, which may couple noise. So, the main rule is that the shorter and thinner the track is, the smaller the parasitic capacitance.

The tracks must be routed as thin as the PCB technology allows to and shorter than 10 cm for standard or flexible PCBs.

### Sensor track routing

The main goal when laying out the PCB, is to minimize the interactions between elements or, if they cannot be minimized, to make them uniform for all capacitive elements.

The touch sensing controller algorithms used to acquire touchkey, linear sensor and rotary sensor signals, take into account that the capacitance of each array is different. However, things must be kept as balanced as possible (see the figure below).

**Figure 29. Track routing recommendation**

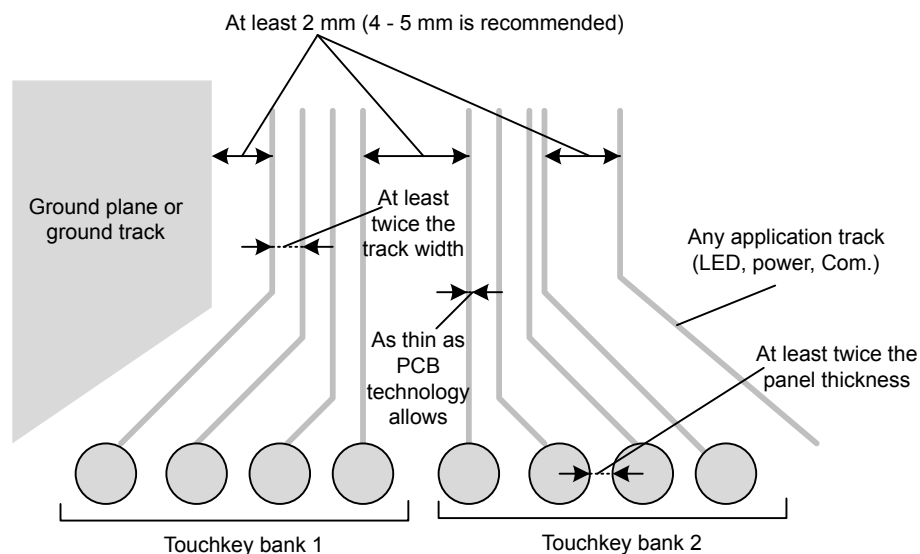

### Electrode banks

A set of electrodes that are driven simultaneously during the acquisition is called an acquisition bank. This set of electrodes and tracks interact less with each other and can be routed closer. Typically, a spacing of twice the track width is sufficient.

For electrodes not belonging to the same bank, coupling must be avoided. A spacing of at least 2 mm is required, and 4 to 5 mm is recommended (see Figure 29).

### Electrode spacing

To avoid cross detection on adjacent electrodes, the gap must be kept at least twice the panel thickness between electrodes (see Figure 29).

### Interaction with other tracks

To avoid creating coupling with lines driving high frequency signals, the sensor tracks must be crossed perpendicularly with the other tracks. This is especially true for communication lines, where it is forbidden to route them in parallel with the sensor tracks. To avoid such a configuration, the pins of the microcontroller must be selected and grouped by function. When it is possible, all the sensor pins are consecutively distributed on one or several sides of the microcontroller package (pins used as GPIOs, like the LED drivers and communication lines). Some pins must be dedicated to be used as sensors and not shared with other features. Sharing tracks produces parasitic capacitance due to re-routing of the sensor tracks, and impacts the sensitivity.

### 3.5.5 Component placement

To reduce the sensor track lengths, the microcontroller must be placed very close to the sensor electrodes. The microcontroller must also be centered among the sensors to balance the parasitic capacitance and to put a ground layer above it.

The ESD protection resistors must also be placed as close as possible to the microcontroller to reduce the track length that may drive ESD disturbance directly to the microcontroller without protection. These ESD resistors must be selected according to the acquisition method recommendations.

### 3.5.6 Ground considerations

#### Ground plane

The sensors and the ground must be routed on the same layer, while the components and other tracks are routed on the other layers.

When a multilayer PCB is used, both sides of the PCB are commonly grounded to improve the immunity to noise. Nevertheless, the ground has an effect on the sensitivity of the sensor. The ground effect is to increase  $C_X$ , that reduces the sensitivity as the ratio  $C_T/C_X$  decreases. To balance between noise immunity and sensitivity, the use of partial grounding on both sides of the PCB through a 15% mesh on the sensor layer and a 10% copper mesh for the opposite side with the electrodes and tracks, is recommended.

#### Ground around sensor

When the ground plane is on the same layer as the sensor, it surrounds the sensors. To avoid increasing  $C_X$ , a gap must be kept between the sensor and the ground.

This gap size must be at least 2 mm (4-5 mm recommended) and must also be respected with any noisy application track or power supply voltage.

There are two different cases listed below:

- Distance to GND and power supply voltage: shorter distance is possible but impacts significantly the touchkey sensitivity.
- Distance to noisy signal: the detection may completely stop working in case the distance is not respected.

Special care must be taken to balance the ground around the sensors. This is particularly true for a rotary or linear sensor (see Section 3.5.2).

**Caution:** Floating planes must never be placed close to the sensors.

#### Ground plane example

A full ground plane is mandatory below the MCU up to serial resistors (see the figure below). It must cover the tracks between the MCU and the serial resistors and sampling capacitors.

Figure 30. Ground plane example

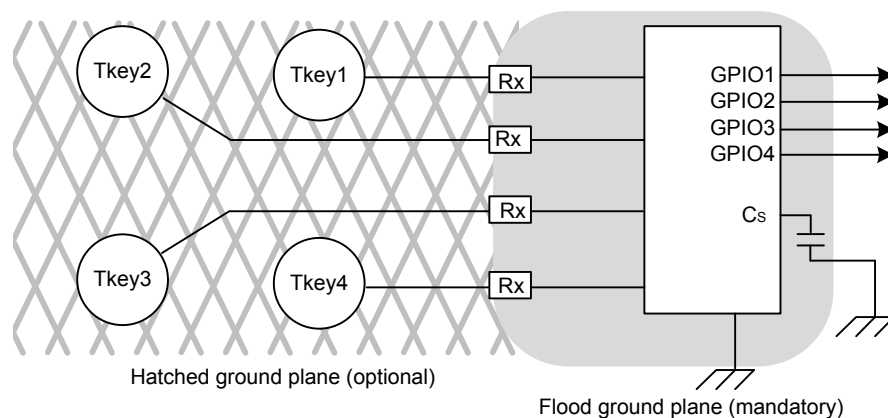



### Hatched ground plane

Here are some guidelines for satisfactorily designing an application with a hatched ground plane (see the figure below):

- The signal track must cross the ground lines as little as possible.
- The signal track must never follow the ground lines.

**Figure 31. Hatched ground and signal tracks**

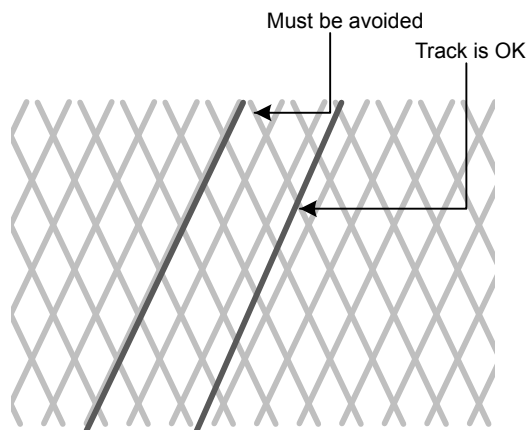

### 3.5.7 Rotary and linear sensor recommendations

Given that the sensitivity must be very high in order to be able to detect the position most accurately, neither the power plane nor any application signal should run under a rotary or linear sensor.

---

## 4 Conclusion

---

The layout and design of capacitive sensing boards usually present conflicts between all signals present on the application. This document presents general guideline for resolving all issues. When the recommendations cannot be followed, tests must be performed to validate the implementation and verify the sensitivity and robustness of the impacted channel.

To summarize, the layout of a touch sensing application must reduce the ground coupling to a minimum and use short clean wires as far as possible from other potential interference sources.

## Revision history

**Table 4. Document revision history**

Date	Version	Changes
30-Sept-2013	1	Initial release.
02-Nov-2016	2	Updated: <ul style="list-style-type: none"> <li>• Table 1: Applicable products</li> <li>• Figure 8: Examples of cases where a LED bypass capacitor is required</li> <li>• Figure 9: TC I/O</li> <li>• Figure 10: FT I/O</li> <li>• Figure 11: Typical power supply schematic</li> </ul> Added Section 2.4: TC versus FT I/O.
28-Jun-2017	3	Updated Section 2.4: TC versus FT I/O.
30-Aug-2018	4	Specific note added in Section 3.3: Linear sensor and Section 3.4: Rotary sensor.
23-Jan-2019	5	Updated: <ul style="list-style-type: none"> <li>• Title of the document</li> <li>• Table 1. Applicable products</li> </ul>
7-May-2021	6	Added: <ul style="list-style-type: none"> <li>• STM32L4+ and STM32L5 Series in Table 1</li> <li>• Figure 9. Avoid to swap resistor and LED</li> </ul> Updated: <ul style="list-style-type: none"> <li>• Figure 8. Examples of cases where a LED bypass capacitor is required</li> <li>• Section 2.4 TC versus FT and TT I/Os</li> </ul>
10-Aug-2021	7	Updated the Applicable products table.
10-Jan-2023	8	Updated the Table 1. Applicable products in the Introduction to incorporate the STM32WBA series. Updated the document with minor changes.
06-Mar-2024	9	Added STM32U0 series Updated document title

## Contents

<b>1</b>	<b>Capacitive sensing technology</b>	<b>2</b>
1.1	Charge transfer acquisition principle	2
1.2	Surface capacitance	3
<b>2</b>	<b>Main capacitive sensing guidelines</b>	<b>4</b>
2.1	Overview	4
2.2	Construction	4
2.2.1	Substrates	4
2.2.2	Electrode and interconnection materials	5
2.2.3	Panel materials	6
2.2.4	Mechanical construction and PCB to panel bonding	8
2.2.5	Metal chassis	8
2.2.6	Air gap	8
2.2.7	Transfer of an electrode from PCB to the front panel	9
2.3	Placing of LEDs close to sensors	9
2.4	TC versus FT and TT I/Os	10
2.5	Power supply	11
<b>3</b>	<b>Surface sensor design</b>	<b>13</b>
3.1	Touchkey sensor	13
3.2	Touchkey matrix sensor	14
3.3	Linear sensor	14
3.3.1	Normal patterned linear sensor	15
3.3.2	Interlaced patterned linear sensor	16
3.4	Rotary sensor	16
3.4.1	Normal patterned rotary sensor	17
3.4.2	Interlaced patterned rotary sensors	18
3.4.3	Rotary sensor with central touchkey	18
3.5	Specific recommendations	19
3.5.1	LEDs and sensors	19
3.5.2	Driven shield	20
3.5.3	Using electrodes separated from the PCB	22
3.5.4	PCB and layout	22
3.5.5	Component placement	23
3.5.6	Ground considerations	24
3.5.7	Rotary and linear sensor recommendations	25
<b>4</b>	<b>Conclusion</b>	<b>26</b>

---

Revision history .....	27
List of tables .....	30
List of figures.....	31

## List of tables

<b>Table 1.</b>	Applicable products . . . . .	1
<b>Table 2.</b>	Potential application problems with flex PCB placement . . . . .	5
<b>Table 3.</b>	Dielectric constants of common materials used in a panel construction . . . . .	7
<b>Table 4.</b>	Document revision history . . . . .	27

## List of figures

Figure 1.	Equivalent touch sensing capacitances . . . . .	3
Figure 2.	Example of capacitive sensor construction . . . . .	4
Figure 3.	Clear ITO on PET with silver connections. . . . .	5
Figure 4.	Silver printing on PET . . . . .	5
Figure 5.	Flexible PCB (FPC). . . . .	6
Figure 6.	FR4 (2-sided epoxy-fiberglass) . . . . .	6
Figure 7.	Typical panel stack-up . . . . .	8
Figure 8.	Examples of cases where a LED bypass capacitor is required . . . . .	9
Figure 9.	Avoid to swap resistor and led . . . . .	9
Figure 10.	TC I/O . . . . .	10
Figure 11.	FT and TT I/Os. . . . .	11
Figure 12.	Typical power supply schematic . . . . .	12
Figure 13.	Sensor size . . . . .	13
Figure 14.	Recommended electrode size . . . . .	13
Figure 15.	Simple matrix implementation. . . . .	14
Figure 16.	Mono electrodes design . . . . .	14
Figure 17.	Half-ended electrodes design . . . . .	14
Figure 18.	Dual electrodes design . . . . .	15
Figure 19.	Normal patterned linear sensor (5 channels/6 half-ended electrodes design electrodes) . . . . .	15
Figure 20.	Interlaced linear touch sensor (3 channels/4 half-ended electrodes design electrodes). . . . .	16
Figure 21.	Normal patterned rotary sensor (3 channels/3 electrodes) . . . . .	17
Figure 22.	Interlaced patterned rotary sensor (3 channels/3 electrodes) . . . . .	18
Figure 23.	Back-lighting touchkey. . . . .	19
Figure 24.	PCB 3D top view. . . . .	19
Figure 25.	PCB bottom view . . . . .	19
Figure 26.	STM32L driven shield example using the charge-transfer acquisition principle . . . . .	21
Figure 27.	Printed electrode method showing several connection methods . . . . .	22
Figure 28.	Spring and foam picture (both are not compressed). . . . .	22
Figure 29.	Track routing recommendation . . . . .	23
Figure 30.	Ground plane example . . . . .	24
Figure 31.	Hatched ground and signal tracks . . . . .	25

**IMPORTANT NOTICE – READ CAREFULLY**

STMicroelectronics NV and its subsidiaries (“ST”) reserve the right to make changes, corrections, enhancements, modifications, and improvements to ST products and/or to this document at any time without notice. Purchasers should obtain the latest relevant information on ST products before placing orders. ST products are sold pursuant to ST’s terms and conditions of sale in place at the time of order acknowledgment.

Purchasers are solely responsible for the choice, selection, and use of ST products and ST assumes no liability for application assistance or the design of purchasers’ products.

No license, express or implied, to any intellectual property right is granted by ST herein.

Resale of ST products with provisions different from the information set forth herein shall void any warranty granted by ST for such product.

ST and the ST logo are trademarks of ST. For additional information about ST trademarks, refer to [www.st.com/trademarks](http://www.st.com/trademarks). All other product or service names are the property of their respective owners.

Information in this document supersedes and replaces information previously supplied in any prior versions of this document.

© 2024 STMicroelectronics – All rights reserved