

ASM330LHBG1: 6-axis IMU with extended temperature range for ASIL B automotive applications

Introduction

This document provides usage information and application hints related to ST's [ASM330LHBG1](#) iNEMO 6-axis IMU (inertial measurement unit).

The ASM330LHBG1 is a 3-axis digital accelerometer and 3-axis digital gyroscope system-in-package with a digital I²C, SPI, and MIPI I3CSM serial interface standard output, performing at 1.3 mA in combo high-performance mode. This device, used in redundancy (as two modules) and in combination with a dedicated software library, has been evaluated as compatible to be adopted in ASIL B automotive applications. This solution is described in detail in application note AN5691.

The ASM330LHBG1 has a full-scale acceleration range of $\pm 2/\pm 4/\pm 8/\pm 16$ g and a wide angular rate range of $\pm 125/\pm 250/\pm 500/\pm 1000/\pm 2000/\pm 4000$ dps that enable its usage in a broad range of automotive applications.

The device supports dual operating modes: high-performance mode and low-power mode.

Supporting dual operating modes, the device has enhanced flexibility versus application requirements, leveraging on multiple voltage and multiple ODR selections. The device also includes digital features like a finite state machine and an ST proprietary machine learning core, allowing defined motion pattern detection or some complex algorithms run in the application processor to be moved to the MEMS sensor with the advantage of consistent reduction in power consumption.

The ASM330LHBG1 has an integrated smart first-in first-out (FIFO) buffer of 3 KB size, allowing dynamic batching of significant data (that is, accelerometer and gyroscope sensors, timestamp, and temperature).

The ASM330LHBG1 is available in a small plastic, land grid array package (LGA-14L) and it is guaranteed to operate over an extended temperature range from -40°C to +125°C.

This device is suitable for telematics and dead-reckoning applications as well as vehicle-to-vehicle (V2X) and impact detection as a result of its high stability over temperature and time, combined with superior sensing precision.

1 Pin description

Figure 1. Pin connections

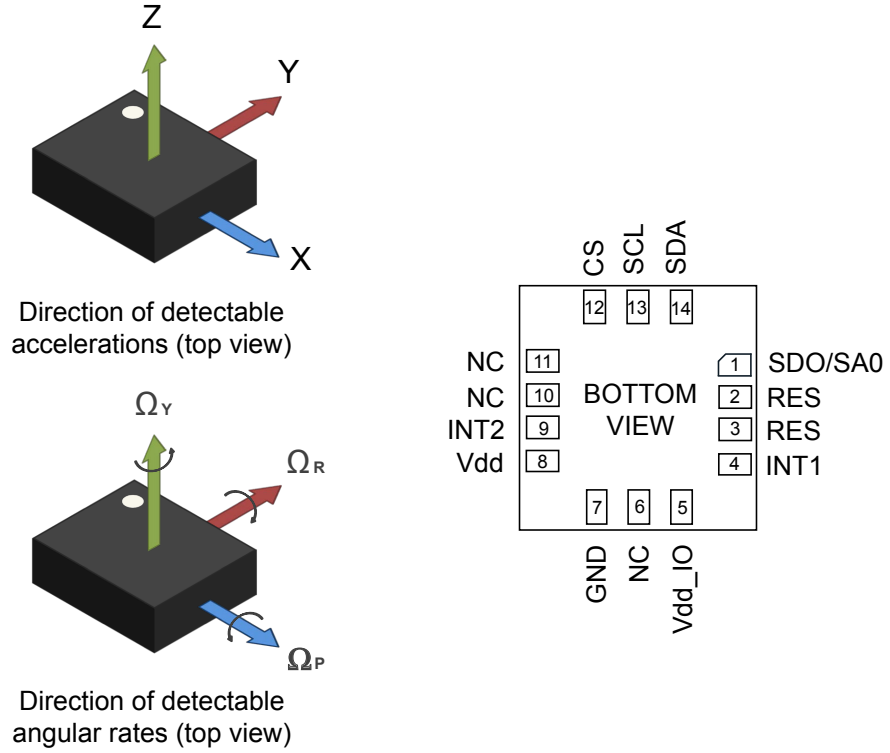

Table 1. Pin status

Pin #	Name	Function	Pin status
1	SDO	SPI 4-wire interface serial data output (SDO)	Default: input without pull-up Pull-up is enabled if bit SDO_PU_EN = 1 in the PIN_CTRL register.
	SA0	I ² C least significant bit of the device address (SA0) MIPI I3C SM least significant bit of the static address (SA0)	
2	RES	Connect to Vdd_IO or GND	Default: input without pull-up (see Note to enable pull-up)
3	RES	Connect to Vdd_IO or GND	Default: input without pull-up (see Note to enable pull-up)
4	INT1 ⁽¹⁾	Programmable interrupt 1 If the device is used as MIPI I3C SM pure slave, this pin must be set to 1.	Default: input with pull-down Pull-down is disabled if bit PD_DIS_INT1 = 1 in I3C_BUS_AVB register.
5	Vdd_IO	Power supply for I/O pins	
6	NC	Connect to Vdd_IO or GND or leave unconnected	
7	GND	0 V supply	
8	Vdd	Power supply	
9	INT2 ⁽²⁾	Programmable interrupt 2 (INT2) / Data enabled (DEN)	Default: output forced to ground
10	NC	Leave unconnected	
11	NC	Leave unconnected	
12	CS	I ² C and MIPI I3C SM / SPI mode selection (1: SPI idle mode / I ² C and MIPI I3C SM communication enabled; 0: SPI communication mode / I ² C and MIPI I3C SM disabled)	Default: input with pull-up Pull-up is disabled if bit I2C_disable = 1 in CTRL4_C register and bit I3C_disable = 1 in CTRL9_XL register.
13	SCL	I ² C/MIPI I3C SM serial clock (SCL) / SPI serial port clock (SPC)	Default: input without pull-up
14	SDA	I ² C/MIPI I3C SM serial data (SDA) / SPI serial data input (SDI) / 3-wire interface serial data output (SDO)	Default: input without pull-up

1. INT1 must be set to 0 or left unconnected during power-on if the I²C/SPI interfaces are used. If no interrupt signal is needed on INT1, this pin can be left unconnected.
2. If no interrupt signal is needed on INT2, this pin can be left unconnected.

Internal pull-up value is from 30 kΩ to 50 kΩ, depending on Vdd_IO.

Note:

The procedure to enable the pull-up on pins 2 and 3 is as follows:

1. From the primary I²C/I3C/SPI interface: write 40h in register at address 01h.
2. From the primary I²C/I3C/SPI interface: write 08h in register at address 14h (enable the pull-up on pins 2 and 3).
3. From the primary I²C/I3C/SPI interface: write 00h in register at address 01h.

2 Registers

Table 2. Registers

Register name	Address	Bit7	Bit6	Bit5	Bit4	Bit3	Bit2	Bit1	Bit0
FUNC_CFG_ACCESS	01h	FUNC_CFG_ACCESS	0	0	0	0	0	0	0
PIN_CTRL	02h	0	SDO_PU_EN	1	1	1	1	1	1
FIFO_CTRL1	07h	WTM7	WTM6	WTM5	WTM4	WTM3	WTM2	WTM1	WTM0
FIFO_CTRL2	08h	STOP_ON_WTM	0	0	ODRCHG_EN	0	0	0	WTM8
FIFO_CTRL3	09h	BDR_GY_3	BDR_GY_2	BDR_GY_1	BDR_GY_0	BDR_XL_3	BDR_XL_2	BDR_XL_1	BDR_XL_0
FIFO_CTRL4	0Ah	DEC_TS_BATCH_1	DEC_TS_BATCH_0	ODR_T_BATCH_1	ODR_T_BATCH_0	0	FIFO_MODE2	FIFO_MODE1	FIFO_MODE0
COUNTER_BDR_REG1	0Bh	dataready_pulsed	RST_COUNTER_BDR	TRIG_COUNTER_BDR	0	0	CNT_BDR_TH_10	CNT_BDR_TH_9	CNT_BDR_TH_8
COUNTER_BDR_REG2	0Ch	CNT_BDR_TH_7	CNT_BDR_TH_6	CNT_BDR_TH_5	CNT_BDR_TH_4	CNT_BDR_TH_3	CNT_BDR_TH_2	CNT_BDR_TH_1	CNT_BDR_TH_0
INT1_CTRL	0Dh	DEN_DRDY_flag	INT1_CNT_BDR	INT1_FIFO_FULL	INT1_FIFO_OVR	INT1_FIFO_TH	INT1_BOOT	INT1_DRDY_G	INT1_DRDY_XL
INT2_CTRL	0Eh	0	INT2_CNT_BDR	INT2_FIFO_FULL	INT2_FIFO_OVR	INT2_FIFO_TH	INT2_DRDY_TEMP	INT2_DRDY_G	INT2_DRDY_XL
WHO_AM_I	0Fh	0	1	1	0	1	0	1	1
CTRL1_XL	10h	ODR_XL3	ODR_XL2	ODR_XL1	ODR_XL0	FS1_XL	FS0_XL	LPF2_XL_EN	0
CTRL2_G	11h	ODR_G3	ODR_G2	ODR_G1	ODR_G0	FS1_G	FS0_G	FS_125	FS_4000
CTRL3_C	12h	BOOT	BDU	H_LACTIVE	PP_OD	SIM	IF_INC	0	SW_RESET
CTRL4_C	13h	0	SLEEP_G	INT2_on_INT1	0	DRDY_MASK	I2C_disable	LPF1_SEL_G	0
CTRL5_C	14h	0	ROUNDING1	ROUNDING0	0	ST1_G	ST0_G	ST1_XL	ST0_XL
CTRL6_C	15h	TRIG_EN	LVL1_EN	LVL2_EN	XL_HM_MODE	USR_OFF_W	FTYPE_2	FTYPE_1	FTYPE_0
CTRL7_G	16h	G_HM_MODE	HP_G_EN	HPM1_G	HPM0_G	0	0	USR_OFF_ON_OUT	0
CTRL8_XL	17h	HPCF_XL2	HPCF_XL1	HPCF_XL0	HP_REF_MODE_XL	FASTSETTL_MODE_XL	HP_SLOPE_XL_EN	0	LOW_PASS_ON_6D
CTRL9_XL	18h	DEN_X	DEN_Y	DEN_Z	DEN_XL_G	DEN_XL_EN	DEN_LH	I3C_disable	0
CTRL10_C	19h	0	0	TIMESTAMP_EN	0	0	0	0	0
ALL_INT_SRC	1Ah	TIMESTAMP_ENDCOUNT	0	SLEEP_CHANGE_IA	D6D_IA	0	0	WU_IA	FF_IA
WAKE_UP_SRC	1Bh	0	SLEEP_CHANGE_IA	FF_IA	SLEEP_STATE	WU_IA	X_WU	Y_WU	Z_WU
D6D_SRC	1Dh	DEN_DRDY	D6D_IA	ZH	ZL	YH	YL	XH	XL
STATUS_REG	1Eh	0	0	0	0	BOOT_CHECK_FAIL	TDA	GDA	XLDA
OUT_TEMP_L	20h	Temp7	Temp6	Temp5	Temp4	Temp3	Temp2	Temp1	Temp0
OUT_TEMP_H	21h	Temp15	Temp14	Temp13	Temp12	Temp11	Temp10	Temp9	Temp8
OUTX_L_G	22h	D7	D6	D5	D4	D3	D2	D1	D0

Register name	Address	Bit7	Bit6	Bit5	Bit4	Bit3	Bit2	Bit1	Bit0
OUTX_H_G	23h	D15	D14	D13	D12	D11	D10	D9	D8
OUTY_L_G	24h	D7	D6	D5	D4	D3	D2	D1	D0
OUTY_H_G	25h	D15	D14	D13	D12	D11	D10	D9	D8
OUTZ_L_G	26h	D7	D6	D5	D4	D3	D2	D1	D0
OUTZ_H_G	27h	D15	D14	D13	D12	D11	D10	D9	D8
OUTX_L_A	28h	D7	D6	D5	D4	D3	D2	D1	D0
OUTX_H_A	29h	D15	D14	D13	D12	D11	D10	D9	D8
OUTY_L_A	2Ah	D7	D6	D5	D4	D3	D2	D1	D0
OUTY_H_A	2Bh	D15	D14	D13	D12	D11	D10	D9	D8
OUTZ_L_A	2Ch	D7	D6	D5	D4	D3	D2	D1	D0
OUTZ_H_A	2Dh	D15	D14	D13	D12	D11	D10	D9	D8
EMB_FUNC_STATUS_MAINPAGE	35h	IS_FSM_LC	0	0	0	0	0	0	0
FSM_STATUS_A_MAINPAGE	36h	IS_FSM8	IS_FSM7	IS_FSM6	IS_FSM5	IS_FSM4	IS_FSM3	IS_FSM2	IS_FSM1
FSM_STATUS_B_MAINPAGE	37h	IS_FSM16	IS_FSM15	IS_FSM14	IS_FSM13	IS_FSM12	IS_FSM11	IS_FSM10	IS_FSM9
MLC_STATUS_MAINPAGE	38h	IS_MLC8	IS_MLC7	IS_MLC6	IS_MLC5	IS_MLC4	IS_MLC3	IS_MLC2	IS_MLC1
FIFO_STATUS1	3Ah	DIFF_FIFO_7	DIFF_FIFO_6	DIFF_FIFO_5	DIFF_FIFO_4	DIFF_FIFO_3	DIFF_FIFO_2	DIFF_FIFO_1	DIFF_FIFO_0
FIFO_STATUS2	3Bh	FIFO_WTM_IA	FIFO_OVR_IA	FIFO_FULL_IA	COUNTER_BDR_IA	FIFO_OVR_LATCHED	0	DIFF_FIFO_9	DIFF_FIFO_8
TIMESTAMP0	40h	T7	T6	T5	T4	T3	T2	T1	T0
TIMESTAMP1	41h	T15	T14	T13	T12	T11	T10	T9	T8
TIMESTAMP2	42h	T23	T22	T21	T20	T19	T18	T17	T16
TIMESTAMP3	43h	T31	T30	T29	T28	T27	T26	T25	T24
INT_CFG0	56h	0	INT_CLR_ON_READ	SLEEP_STATUS_ON_INT	SLOPE_FDS	0	0	0	LIR
INT_CFG1	58h	INTERRUPTS_ENABLE	INACT_EN1	INACT_EN0	0	0	0	0	0
THS_6D	59h	D4D_EN	SIXD_THS1	SIXD_THS0	0	0	0	0	0
WAKE_UP_THS	5Bh	0	USR_OFF_ON_WU	WK_THS5	WK_THS4	WK_THS3	WK_THS2	WK_THS1	WK_THS0
WAKE_UP_DUR	5Ch	FF_DUR5	WAKE_DUR1	WAKE_DUR0	WAKE_THS_W	SLEEP_DUR3	SLEEP_DUR2	SLEEP_DUR1	SLEEP_DUR0
FREE_FALL	5Dh	FF_DUR4	FF_DUR3	FF_DUR2	FF_DUR1	FF_DUR0	FF_THS2	FF_THS1	FF_THS0
MD1_CFG	5Eh	INT1_SLEEP_CHANGE	0	INT1_WU	INT1_FF	0	INT1_6D	INT1_EMB_FUNC	0
MD2_CFG	5Fh	INT2_SLEEP_CHANGE	0	INT2_WU	INT2_FF	0	INT2_6D	INT2_EMB_FUNC	INT2_TIMESTAMP
I3C_BUS_AVB	62h	0	0	0	I3C_Bus_Avb_Sel1	I3C_Bus_Avb_Sel0	0	0	PD_DIS_INT1





Register name	Address	Bit7	Bit6	Bit5	Bit4	Bit3	Bit2	Bit1	Bit0
INTERNAL_FREQ_FINE	63h	FREQ_FINE7	FREQ_FINE6	FREQ_FINE5	FREQ_FINE4	FREQ_FINE3	FREQ_FINE2	FREQ_FINE1	FREQ_FINE0
X_OFS_USR	73h	X_OFS_USR_7	X_OFS_USR_6	X_OFS_USR_5	X_OFS_USR_4	X_OFS_USR_3	X_OFS_USR_2	X_OFS_USR_1	X_OFS_USR_0
Y_OFS_USR	74h	Y_OFS_USR_7	Y_OFS_USR_6	Y_OFS_USR_5	Y_OFS_USR_4	Y_OFS_USR_3	Y_OFS_USR_2	Y_OFS_USR_1	Y_OFS_USR_0
Z_OFS_USR	75h	Z_OFS_USR_7	Z_OFS_USR_6	Z_OFS_USR_5	Z_OFS_USR_4	Z_OFS_USR_3	Z_OFS_USR_2	Z_OFS_USR_1	Z_OFS_USR_0
FIFO_DATA_OUT_TAG	78h	TAG_SENSOR_4	TAG_SENSOR_3	TAG_SENSOR_2	TAG_SENSOR_1	TAG_SENSOR_0	TAG_CNT_1	TAG_CNT_0	TAG_PARITY
FIFO_DATA_OUT_X_L	79h	D7	D6	D5	D4	D3	D2	D1	D0
FIFO_DATA_OUT_X_H	7Ah	D15	D14	D13	D12	D11	D10	D9	D8
FIFO_DATA_OUT_Y_L	7Bh	D7	D6	D5	D4	D3	D2	D1	D0
FIFO_DATA_OUT_Y_H	7Ch	D15	D14	D13	D12	D11	D10	D9	D8
FIFO_DATA_OUT_Z_L	7Dh	D7	D6	D5	D4	D3	D2	D1	D0
FIFO_DATA_OUT_Z_H	7Eh	D15	D14	D13	D12	D11	D10	D9	D8

2.1 Embedded functions registers

The table given below provides a list of the registers for the embedded functions available in the device and the corresponding addresses. Embedded functions registers are accessible when the FUNC_CFG_ACCESS bit is set to 1 in the FUNC_CFG_ACCESS register.

Table 3. Embedded functions registers

Register name	Address	Bit7	Bit6	Bit5	Bit4	Bit3	Bit2	Bit1	Bit0
PAGE_SEL	02h	PAGE_SEL3	PAGE_SEL2	PAGE_SEL1	PAGE_SEL0	0	0	EMB_FUNC_CLK_DIS	1
EMB_FUNC_EN_B	05h	0	0	0	MLC_EN	0	0	0	FSM_EN
PAGE_ADDRESS	08h	PAGE_ADDR7	PAGE_ADDR6	PAGE_ADDR5	PAGE_ADDR4	PAGE_ADDR3	PAGE_ADDR2	PAGE_ADDR1	PAGE_ADDR0
PAGE_VALUE	09h	PAGE_VALUE7	PAGE_VALUE6	PAGE_VALUE5	PAGE_VALUE4	PAGE_VALUE3	PAGE_VALUE2	PAGE_VALUE1	PAGE_VALUE0
EMB_FUNC_INT1	0Ah	INT1_FSM_LC	0	0	0	0	0	0	0
FSM_INT1_A	0Bh	INT1_FSM8	INT1_FSM7	INT1_FSM6	INT1_FSM5	INT1_FSM4	INT1_FSM3	INT1_FSM2	INT1_FSM1
FSM_INT1_B	0Ch	INT1_FSM16	INT1_FSM15	INT1_FSM14	INT1_FSM13	INT1_FSM12	INT1_FSM11	INT1_FSM10	INT1_FSM9
MLC_INT1	0Dh	INT1_MLC8	INT1_MLC7	INT1_MLC6	INT1_MLC5	INT1_MLC4	INT1_MLC3	INT1_MLC2	INT1_MLC1
EMB_FUNC_INT2	0Eh	INT2_FSM_LC	0	0	0	0	0	0	0
FSM_INT2_A	0Fh	INT2_FSM8	INT2_FSM7	INT2_FSM6	INT2_FSM5	INT2_FSM4	INT2_FSM3	INT2_FSM2	INT2_FSM1
FSM_INT2_B	10h	INT2_FSM16	INT2_FSM15	INT2_FSM14	INT2_FSM13	INT2_FSM12	INT2_FSM11	INT2_FSM10	INT2_FSM9
MLC_INT2	11h	INT2_MLC8	INT2_MLC7	INT2_MLC6	INT2_MLC6	INT2_MLC4	INT2_MLC3	INT2_MLC2	INT2_MLC1
EMB_FUNC_STATUS	12h	IS_FSM_LC	0	0	0	0	0	0	0
FSM_STATUS_A	13h	IS_FSM8	IS_FSM7	IS_FSM6	IS_FSM5	IS_FSM4	IS_FSM3	IS_FSM2	IS_FSM1
FSM_STATUS_B	14h	IS_FSM16	IS_FSM15	IS_FSM14	IS_FSM13	IS_FSM12	IS_FSM11	IS_FSM10	IS_FSM9
MLC_STATUS	15h	IS_MLC8	IS_MLC7	IS_MLC6	IS_MLC5	IS_MLC4	IS_MLC3	IS_MLC2	IS_MLC1
PAGE_RW	17h	EMB_FUNC_LIR	PAGE_WRITE	PAGE_READ	0	0	0	0	0
FSM_ENABLE_A	46h	FSM8_EN	FSM7_EN	FSM6_EN	FSM5_EN	FSM4_EN	FSM3_EN	FSM2_EN	FSM1_EN
FSM_ENABLE_B	47h	FSM16_EN	FSM15_EN	FSM14_EN	FSM13_EN	FSM12_EN	FSM11_EN	FSM10_EN	FSM9_EN
FSM_LONG_COUNTER_L	48h	FSM_LC_7	FSM_LC_6	FSM_LC_5	FSM_LC_4	FSM_LC_3	FSM_LC_2	FSM_LC_1	FSM_LC_0
FSM_LONG_COUNTER_H	49h	FSM_LC_15	FSM_LC_14	FSM_LC_13	FSM_LC_12	FSM_LC_11	FSM_LC_10	FSM_LC_9	FSM_LC_8
FSM_LONG_COUNTER_CLEAR	4Ah	0	0	0	0	0	0	FSM_LC_CLEARED	FSM_LC_CLEAR
FSM_OUTS1	4Ch	P_X	N_X	P_Y	N_Y	P_Z	N_Z	P_V	N_V
FSM_OUTS2	4Dh	P_X	N_X	P_Y	N_Y	P_Z	N_Z	P_V	N_V
FSM_OUTS3	4Eh	P_X	N_X	P_Y	N_Y	P_Z	N_Z	P_V	N_V
FSM_OUTS4	4Fh	P_X	N_X	P_Y	N_Y	P_Z	N_Z	P_V	N_V
FSM_OUTS5	50h	P_X	N_X	P_Y	N_Y	P_Z	N_Z	P_V	N_V
FSM_OUTS6	51h	P_X	N_X	P_Y	N_Y	P_Z	N_Z	P_V	N_V
FSM_OUTS7	52h	P_X	N_X	P_Y	N_Y	P_Z	N_Z	P_V	N_V



Register name	Address	Bit7	Bit6	Bit5	Bit4	Bit3	Bit2	Bit1	Bit0
FSM_OUTS8	53h	P_X	N_X	P_Y	N_Y	P_Z	N_Z	P_V	N_V
FSM_OUTS9	54h	P_X	N_X	P_Y	N_Y	P_Z	N_Z	P_V	N_V
FSM_OUTS10	55h	P_X	N_X	P_Y	N_Y	P_Z	N_Z	P_V	N_V
FSM_OUTS11	56h	P_X	N_X	P_Y	N_Y	P_Z	N_Z	P_V	N_V
FSM_OUTS12	57h	P_X	N_X	P_Y	N_Y	P_Z	N_Z	P_V	N_V
FSM_OUTS13	58h	P_X	N_X	P_Y	N_Y	P_Z	N_Z	P_V	N_V
FSM_OUTS14	59h	P_X	N_X	P_Y	N_Y	P_Z	N_Z	P_V	N_V
FSM_OUTS15	5Ah	P_X	N_X	P_Y	N_Y	P_Z	N_Z	P_V	N_V
FSM_OUTS16	5Bh	P_X	N_X	P_Y	N_Y	P_Z	N_Z	P_V	N_V
EMB_FUNC_ODR_CFG_B	5Fh	0	1	0	FSM_ODR1	FSM_ODR0	0	1	1
EMB_FUNC_ODR_CFG_C	60h	0	0	MLC_ODR1	MLC_ODR0	0	1	0	1
EMB_FUNC_INIT_B	67h	0	0	0	MLC_INIT	0	0	0	FSM_INIT
MLC0_SRC	70h	MLC0_SRC_7	MLC0_SRC_6	MLC0_SRC_5	MLC0_SRC_4	MLC0_SRC_3	MLC0_SRC_2	MLC0_SRC_1	MLC0_SRC_0
MLC1_SRC	71h	MLC1_SRC_7	MLC1_SRC_6	MLC1_SRC_5	MLC1_SRC_4	MLC1_SRC_3	MLC1_SRC_2	MLC1_SRC_1	MLC1_SRC_0
MLC2_SRC	72h	MLC2_SRC_7	MLC2_SRC_6	MLC2_SRC_5	MLC2_SRC_4	MLC2_SRC_3	MLC2_SRC_2	MLC2_SRC_1	MLC2_SRC_0
MLC3_SRC	73h	MLC3_SRC_7	MLC3_SRC_6	MLC3_SRC_5	MLC3_SRC_4	MLC3_SRC_3	MLC3_SRC_2	MLC3_SRC_1	MLC3_SRC_0
MLC4_SRC	74h	MLC4_SRC_7	MLC4_SRC_6	MLC4_SRC_5	MLC4_SRC_4	MLC4_SRC_3	MLC4_SRC_2	MLC4_SRC_1	MLC4_SRC_0
MLC5_SRC	75h	MLC5_SRC_7	MLC5_SRC_6	MLC5_SRC_5	MLC5_SRC_4	MLC5_SRC_3	MLC5_SRC_2	MLC5_SRC_1	MLC5_SRC_0
MLC6_SRC	76h	MLC6_SRC_7	MLC6_SRC_6	MLC6_SRC_5	MLC6_SRC_4	MLC6_SRC_3	MLC6_SRC_2	MLC6_SRC_1	MLC6_SRC_0
MLC7_SRC	77h	MLC7_SRC_7	MLC7_SRC_6	MLC7_SRC_5	MLC7_SRC_4	MLC7_SRC_3	MLC7_SRC_2	MLC7_SRC_1	MLC7_SRC_0



2.2 Embedded advanced features pages

The following table provides a list of the registers for the embedded advanced features page 1. These registers are accessible when PAGE_SEL[3:0] are set to 0001 in the PAGE_SEL register.

Table 4. Embedded advanced features registers - page 1

Register name	Address	Bit7	Bit6	Bit5	Bit4	Bit3	Bit2	Bit1	Bit0
FSM_LC_TIMEOUT_L	7Ah	FSM_LC_TIMEOUT7	FSM_LC_TIMEOUT6	FSM_LC_TIMEOUT5	FSM_LC_TIMEOUT4	FSM_LC_TIMEOUT3	FSM_LC_TIMEOUT2	FSM_LC_TIMEOUT1	FSM_LC_TIMEOUT0
FSM_LC_TIMEOUT_H	7Bh	FSM_LC_TIMEOUT15	FSM_LC_TIMEOUT14	FSM_LC_TIMEOUT13	FSM_LC_TIMEOUT12	FSM_LC_TIMEOUT11	FSM_LC_TIMEOUT10	FSM_LC_TIMEOUT9	FSM_LC_TIMEOUT8
FSM_PROGRAMS	7Ch	FSM_N_PROG7	FSM_N_PROG6	FSM_N_PROG5	FSM_N_PROG4	FSM_N_PROG3	FSM_N_PROG2	FSM_N_PROG1	FSM_N_PROG0
FSM_START_ADD_L	7Eh	FSM_START7	FSM_START6	FSM_START5	FSM_START4	FSM_START3	FSM_START2	FSM_START1	FSM_START0
FSM_START_ADD_H	7Fh	FSM_START15	FSM_START14	FSM_START13	FSM_START12	FSM_START11	FSM_START10	FSM_START9	FSM_START8



3 Operating modes

The ASM330LHBG1 provides three possible operating configurations:

- Only accelerometer active and gyroscope in power-down or sleep mode
- Only gyroscope active and accelerometer in power-down
- Both accelerometer and gyroscope active with independent ODR

The device offers a wide Vdd voltage range from 1.71 V to 3.6 V and a Vdd_IO range from 1.62 V to 3.6 V. The power-on sequence is not restricted. The Vdd/Vdd_IO pins can be either set to the power supply level or to ground level (they must not be left floating) and no specific sequence is required for powering them on.

In order to avoid potential conflicts, during the power-on sequence it is recommended to set the lines (on the host side) connected to the device IO pins floating or connected to ground, until Vdd_IO is set. After Vdd_IO is set, the lines connected to the IO pins have to be configured according to their default status described in [Table 1. Pin status](#). In order to avoid an unexpected increase in current consumption, the input pins which are not pulled-up/pulled-down must be polarized by the host.

When the Vdd power supply is applied, the device performs a 10 ms (maximum) boot procedure to load the trimming parameters. After the boot is completed, both the accelerometer and the gyroscope are automatically configured in power-down mode. To guarantee proper power-off of the device it is recommended to maintain the duration of the Vdd line to GND for at least 100 μ s.

The accelerometer and the gyroscope can be configured independently. The accelerometer can be configured in three different power modes: power-down, low-power, and high-performance mode. The gyroscope can be configured in three different power modes: power-down, low-power, and high-performance mode. They are allowed to have different data rates without any limit. The gyroscope sensor can also be set to sleep mode to reduce its power consumption.

When both the accelerometer and gyroscope are on, the accelerometer is synchronized with the gyroscope, and the data rates of the two sensors are integer multiples of each other.

Referring to the datasheet, the output data rate (ODR_XL) bits of CTRL1_XL register and the high-performance disable (XL_HM_MODE) bit of the CTRL6_C register are used to select the output data rate and the power mode of the accelerometer ([Table 5. Accelerometer ODR and power mode selection](#)).

Note: *If the accelerometer is to be activated in high-performance operating mode while the gyroscope is already running (that is, the gyroscope is not in power-down mode), proceed as follows:*

1. *Disable the accelerometer high-performance operating mode (set the XL_HM_MODE bit to 1 in the CTRL6_C (15h) register).*
2. *Write the CTRL1_XL (10h) register to 50h.*
3. *Read the OUTZ_H_A (2Dh) register to clear the XLDA bit in the STATUS_REG (1Eh) register.*
4. *Wait 1/ODR_XL time period or wait until the XLDA bit in the STATUS_REG (1Eh) register becomes equal to 1.*
5. *Enable the accelerometer high-performance operating mode (set the XL_HM_MODE bit to 0 in the CTRL6_C (15h) register).*
6. *Write the CTRL1_XL (10h) register to the desired value.*

Table 5. Accelerometer ODR and power mode selection

ODR_XL[3:0]	ODR when XL_HM_MODE = 1	ODR when XL_HM_MODE = 0
0000	Power-down	Power-down
1011	1.6 Hz (low-power mode)	N.A.
0001	12.5 Hz (low-power mode)	12.5 Hz (high-performance mode)
0010	26 Hz (low-power mode)	26 Hz (high-performance mode)
0011	52 Hz (low-power mode)	52 Hz (high performance mode)
0100	104 Hz (low-power mode)	104 Hz (high-performance mode)
0101	208 Hz (low-power mode)	208 Hz (high-performance mode)
0110	416 Hz (high-performance)	416 Hz (high-performance mode)
0111	833 Hz (high-performance mode)	833 Hz (high-performance mode)
1000	1667 Hz (high-performance mode)	1667 Hz (high-performance mode)

The output data rate (ODR_G) bits of the CTRL2_G register and the high-performance disable (G_HM_MODE) bit of the CTRL7_G register are used to select the output data rate and power mode of the gyroscope sensor (Table 6. Gyroscope ODR and power mode selection).

Table 6. Gyroscope ODR and power mode selection

ODR_G[3:0]	ODR when G_HM_MODE = 1	ODR when G_HM_MODE = 0
0000	Power-down	Power-down
0001	12.5 Hz (low-power mode)	12.5 Hz (high-performance mode)
0010	26 Hz (low-power mode)	26 Hz (high-performance mode)
0011	52 Hz (low-power mode)	52 Hz (high-performance mode)
0100	104 Hz (low-power mode)	104 Hz (high-performance mode)
0101	208 Hz (low-power mode)	208 Hz (high-performance mode)
0110	416 Hz (high-performance)	416 Hz (high-performance mode)
0111	833 Hz (high-performance mode)	833 Hz (high-performance mode)
1000	1667 Hz (high-performance mode)	1667 Hz (high-performance mode)

Table 7 and Table 8 show the typical value (at temperature equal to 25°C) of the power consumption at Vdd = 3.0 V and at Vdd = 1.8 V, respectively, for the different operating modes.

Table 7. Power consumption at Vdd = 3.0 V, T = 25°C

ODR [Hz]	Accelerometer only	Gyroscope only	Combo [accelerometer + gyroscope]
Power-down	-	-	5 µA
Sleep	-	430 µA	-
1.6 Hz (low-power mode)	7 µA	-	-
12.5 Hz (low-power mode)	14 µA	450 µA	475 µA
26 Hz (low-power mode)	20 µA	465 µA	500 µA
52 Hz (low-power mode)	50 µA	500 µA	530 µA
104 Hz (low-power mode)	60 µA	570 µA	630 µA
208 Hz (low-power mode)	120 µA	710 µA	800 µA
12.5 Hz (high-performance mode)	360 µA	990 µA	1.3 mA
26 Hz (high-performance mode)	360 µA	990 µA	1.3 mA
52 Hz (high-performance mode)	360 µA	990 µA	1.3 mA
104 Hz (high-performance mode)	360 µA	990 µA	1.3 mA
208 Hz (high-performance mode)	360 µA	990 µA	1.3 mA
416 Hz (high-performance mode)	360 µA	990 µA	1.3 mA
833 Hz (high-performance mode)	360 µA	990 µA	1.3 mA
1667 Hz (high-performance mode)	360 µA	990 µA	1.3 mA

Table 8. Power consumption at Vdd = 1.8 V, T = 25°C

ODR [Hz]	Accelerometer only	Gyroscope only	Combo [accelerometer + gyroscope]
Power-down	-	-	5 µA
Sleep	-	420 µA	-
1.6 Hz (low-power mode)	5.5 µA	-	-
12.5 Hz (low-power mode)	11 µA	440 µA	470 µA
26 Hz (low-power mode)	18 µA	460 µA	485 µA
52 Hz (low-power mode)	40 µA	490 µA	520 µA
104 Hz (low-power mode)	55 µA	560 µA	610 µA
208 Hz (low-power mode)	105 µA	700 µA	780 µA
12.5 Hz (high-performance mode)	355 µA	980 µA	1.28 mA
26 Hz (high-performance mode)	355 µA	980 µA	1.28 mA
52 Hz (high-performance mode)	355 µA	980 µA	1.28 mA
104 Hz (high-performance mode)	355 µA	980 µA	1.28 mA
208 Hz (high-performance mode)	355 µA	980 µA	1.28 mA
416 Hz (high-performance mode)	355 µA	980 µA	1.28 mA
833 Hz (high-performance mode)	355 µA	980 µA	1.28 mA
1667 Hz (high-performance mode)	355 µA	980 µA	1.28 mA

3.1 Power-down mode

When the accelerometer/gyroscope is in power-down mode, almost all internal blocks of the device are switched off to minimize power consumption. Digital interfaces (I²C, MIPI I3CSM, and SPI) are still active to allow communication with the device. The content of the configuration registers is preserved and the output data registers are not updated, keeping the last data sampled in memory before going into power-down mode.

3.2 High-performance mode

In high-performance mode, all accelerometer/gyroscope circuitry is always on and data are generated at the data rate selected through the ODR_XL/ODR_G bits.

Data interrupt generation is active.

3.3 Low-power mode

While high-performance mode guarantees the best performance in terms of noise, low-power mode further reduces the current consumption. The accelerometer/gyroscope data reading chain is automatically turned on and off to save power. In the gyroscope device, only the driving circuitry is always on.

Data interrupt generation is active.

3.4 Gyroscope sleep mode

While the gyroscope is in sleep mode the circuitry that drives the oscillation of the gyroscope mass is kept active. Compared to gyroscope power-down, turn-on time from sleep mode to low-power/high-performance mode is drastically reduced.

If the gyroscope is not configured in power-down mode, it enters in sleep mode when the sleep mode (SLEEP_G) bit of CTRL4_C register is set to 1, regardless of the selected gyroscope ODR.

3.5 Accelerometer bandwidth

The accelerometer sampling chain is represented by a cascade of three main blocks: an ADC converter, a digital low-pass filter (LPF1), and the composite group of digital filters.

Figure 2. Accelerometer filtering chain shows the accelerometer sampling chain.

The analog signal coming from the mechanical parts is converted by the ADC. Then, the digital LPF1 filter provides different cutoff values based on the accelerometer mode selected:

- ODR / 2 when the accelerometer is configured in high-performance mode
- 780 Hz when the accelerometer is configured in low-power mode

Figure 2. Accelerometer filtering chain

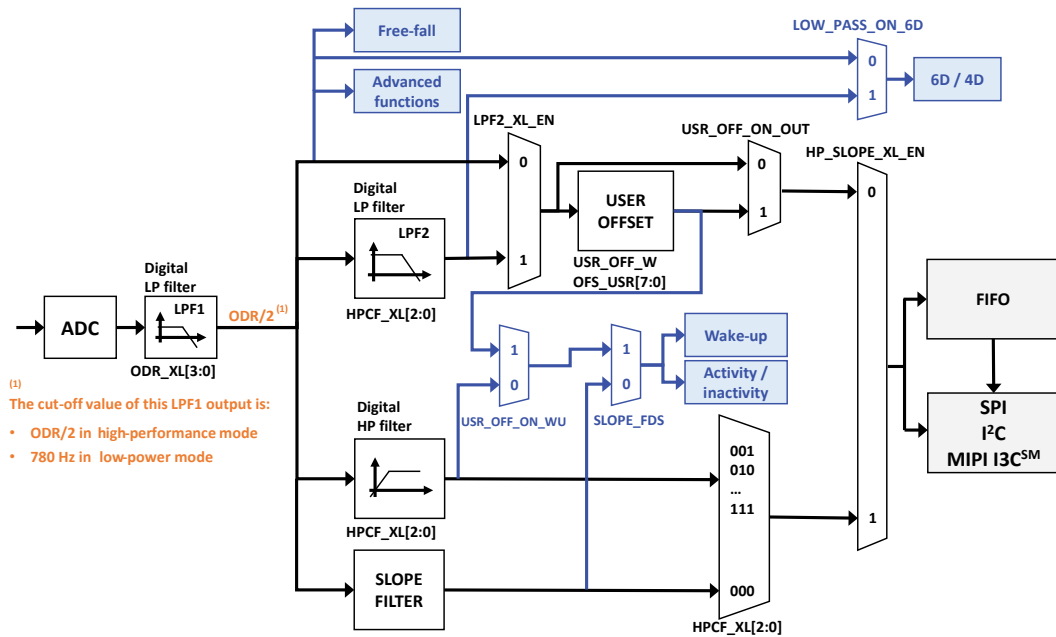

The “Advanced functions” block in the figure above refers to the finite state machine and the machine learning core.

Finally, the composite group of filters composed of a low-pass digital filter (LPF2), a high-pass digital filter, and a slope filter processes the digital signal.

The LPF2_XL_EN bit of the CTRL1_XL register and the CTRL8_XL register can be used to configure the composite filter group and the overall bandwidth of the accelerometer filtering chain, as shown in Table 9. Accelerometer bandwidth selection. Referring to this table, on the low-pass path side, the bandwidth columns refer to the LPF1 bandwidth if LPF2_XL_EN = 0. They refer to the LPF2 bandwidth if LPF2_XL_EN = 1. On the high-pass path side, the bandwidth columns refer to the slope filter bandwidth if HPCF_XL[2:0] = 000. They refer to the HP filter bandwidth for all the other configurations.

Table 9. Accelerometer bandwidth selection also provides the maximum (worst case) settling time in terms of samples to be discarded for the various configurations of the accelerometer filtering chain.

Table 9. Accelerometer bandwidth selection

HP_SLOPE_XL_EN	LPF2_XL_EN	HPCF_XL[2:0]	Bandwidth HP	Bandwidth LP	Max overall settling time ⁽¹⁾ (samples to be discarded)
0 (Low-pass path)	0	-	ODR / 2	780 Hz	See Table 11
	1	000	ODR / 4		See Table 11
		001	ODR / 10		10
		010	ODR / 20		19
		011	ODR / 45		38
		100	ODR / 100		75
		101	ODR / 200		150
		110	ODR / 400		296
		111	ODR / 800		595
1 (High-pass path)	-	000	ODR / 4 (slope filter)		See Table 11
		001	ODR / 10		14
		010	ODR / 20		19
		011	ODR / 45		38
		100	ODR / 100		75
		101	ODR / 200		150
		110	ODR / 400		296
		111	ODR / 800		595

1. Settling time @ 99% of the final value, taking into account all output data rates and all operating mode switches

Setting the HP_SLOPE_XL_EN bit to 0, the low-pass path of the composite filter block is selected. If the LPF2_XL_EN bit is set to 0, no additional filter is applied. If the LPF2_XL_EN bit is set to 1, the LPF2 filter is applied in addition to LPF1 and the overall bandwidth of the accelerometer chain can be set by configuring the HPCF_XL[2:0] field of the CTRL8_XL register.

The LPF2 low-pass filter can also be used in the 6D/4D functionality by setting the LOW_PASS_ON_6D bit of the CTRL8_XL register to 1.

Setting the HP_SLOPE_XL_EN bit to 1, the high-pass path of the composite filter block is selected. The HPCF_XL[2:0] field is used in order to enable, in addition to the LPF1 filter, either the slope filter usage (when HPCF_XL[2:0] = 000) or the digital high-pass filter (other HPCF_XL[2:0] configurations). The HPCF_XL[2:0] field is also used to select the cutoff frequencies of the HP filter.

The high-pass filter reference mode feature is available for the accelerometer sensor. When this feature is enabled, the current X, Y, Z accelerometer sample is internally stored and subtracted from all subsequent output values. In order to enable the reference mode, both the HP_REF_MODE_XL bit and the HP_SLOPE_XL_EN bit of the CTRL8_XL register have to be set to 1, and the value of the HPCF_XL[2:0] field must be equal to 111. When the reference mode feature is enabled, both the LPF2 filter and the HP filter are not available. The first accelerometer output data after enabling the reference mode has to be discarded.

The FASTSETTL_MODE_XL bit of the CTRL8_XL register enables the accelerometer LPF2 or HPF fast-settling mode. The selected filter sets the second sample after writing this bit. This feature applies only upon device exit from power-down mode.

3.5.1 Accelerometer slope filter

As shown in [Figure 3. Accelerometer slope filter](#), the device embeds a digital slope filter, which can also be used for some embedded features such as wake-up detection and activity/inactivity.

The slope filter output data is computed using the following formula:

$$\text{slope}(t_n) = [\text{acc}(t_n) - \text{acc}(t_{n-1})] / 2$$

An example of a slope data signal is illustrated in the following figure.

Figure 3. Accelerometer slope filter

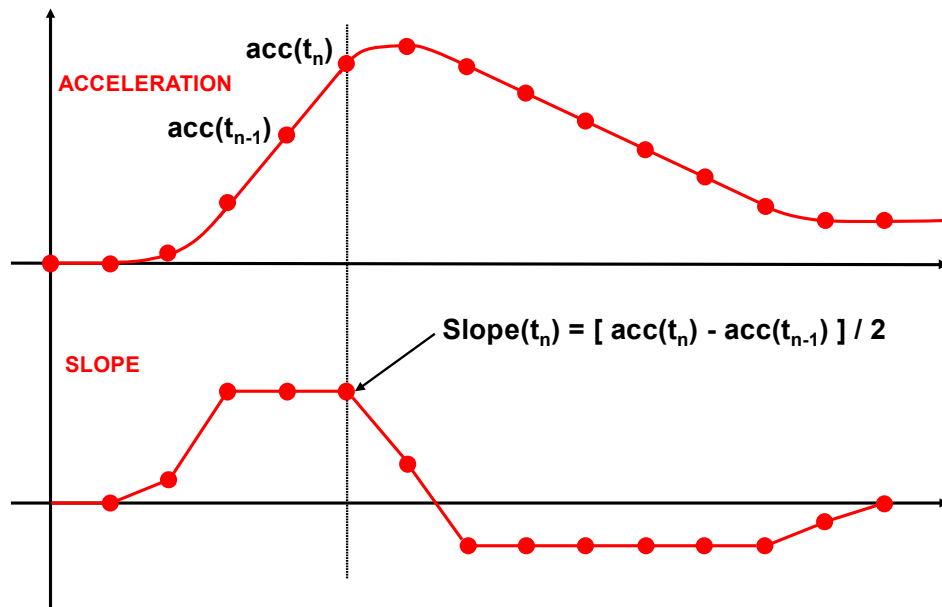

3.6 Accelerometer turn-on/off time

The accelerometer reading chain contains low-pass filtering to improve signal-to-noise performance and to reduce aliasing effects. For this reason, it is necessary to take into account the settling time of the filters when the accelerometer power mode is switched or when the accelerometer ODR is changed.

Accelerometer chain settling time is dependent on the power mode and output data rate selected for the following configurations:

- LPF2 and HP filters disabled
- LPF2 or HP filter enabled with ODR/4 bandwidth selection

For these two possible configurations, the maximum overall turn-on/off in order to switch accelerometer power modes or accelerometer ODR is the one shown in [Table 10. Accelerometer turn-on/off time \(LPF2 and HP disabled\)](#) and [Table 11. Accelerometer samples to be discarded](#)

Note: Accelerometer ODR timing is not impacted by power mode changes (the new configuration takes effect after the completion of the current period).

Table 10. Accelerometer turn-on/off time (LPF2 and HP disabled)

Starting mode	Target mode	Max turn-on/off time ⁽¹⁾
Power-down	Low-power	See Table 11
Power-down	High-performance	See Table 11
Low-power	High-performance	See Table 11 + discard 1 additional sample
Low-power	Low-power (ODR change)	See Table 11
High-performance	Low-power	See Table 11 + discard 1 additional sample
High-performance	High-performance (ODR change)	Discard 3 samples
Low-power / high-performance	Power-down	1 μ s

1. Settling time @ 99% of the final value

Table 11. Accelerometer samples to be discarded

Target mode Accelerometer ODR [Hz]	Number of samples to be discarded (LPF2 and HP filters disabled)	Number of samples to be discarded (LPF2 or HP filter enabled @ODR/4 bandwidth)
1.6 (low-power)	1	2
12.5 (low-power)	1	2
26 (low-power)	1	2
52 (low-power)	1	2
104 (low-power)	1	2
208 (low-power)	1	2
12.5 (high-performance)	2	3
26 (high-performance)	2	3
52 (high-performance)	2	3
104 (high-performance)	2	3
208 (high-performance)	2	3
416 (high-performance)	2	3
833 (high-performance)	2	3
1667 (high-performance)	3	3

Overall settling time if LPF2 or HP digital filters are enabled with bandwidth different from ODR/4 has been already indicated in [Table 9. Accelerometer bandwidth selection](#).

3.7 Gyroscope bandwidth

The gyroscope filtering chain configuration is shown in Figure 4. Gyroscope digital chain. It is a cascade of three filters: a selectable digital high-pass filter (HPF), a selectable digital low-pass filter (LPF1) and a digital low-pass filter (LPF2).

Figure 4. Gyroscope digital chain

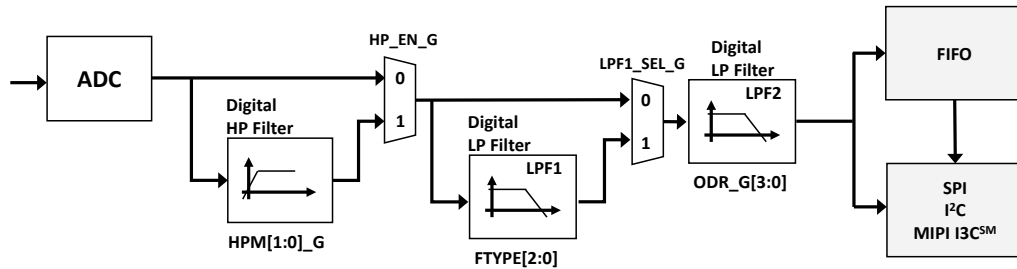

In high-performance mode, the digital HP filter can be enabled by setting the bit HP_EN_G of CTRL7_G register to 1. The digital HP filter cutoff frequency can be selected through the field HPM_G[1:0] of CTRL7_G register, according to the following table.

Table 12. Gyroscope digital HP filter cutoff selection

HPM_G[1:0]	High-pass filter cutoff frequency [Hz]	Overall maximum settling time [s] ⁽¹⁾
00	0.016	45
01	0.065	11
10	0.260	3
11	1.040	0.7

1. Settling time @ 99% of the final value

The digital LPF1 filter can be enabled by setting the LPF1_SEL_G bit of CTRL4_C register to 1 and its bandwidth can be selected through the field FTYPE_[2:0] of CTRL6_C register.

The digital LPF2 filter cannot be configured by the user and its cutoff frequency depends on the selected gyroscope ODR.

The overall gyroscope bandwidth for different gyroscope ODR values and for different configurations of the LPF1_SEL_G bit of CTRL4_C register and FTYPE_[2:0] of CTRL6_C register is summarized in the following table.

Table 13. Gyroscope overall bandwidth selection

Gyroscope ODR [Hz]	LPF1_SEL_G	FTYPE[2:0]	Bandwidth [Hz] (phase delay @ 20 Hz)
12.5	0	-	4.3 (-35° @ 1.3 Hz)
	1	0xx	4.3 (-35° @ 1.3 Hz)
	1	100	4.3 (-35° @ 1.3 Hz)
	1	101	4.3 (-35° @ 1.3 Hz)
	1	110	4.3 (-35° @ 1.3 Hz)
	1	111	4.3 (-35° @ 1.3 Hz)
26	0	-	8.3 (-35° @ 2.5 Hz)
	1	0xx	8.3 (-35° @ 2.5 Hz)
	1	100	8.3 (-35° @ 2.5 Hz)
	1	101	8.3 (-35° @ 2.5 Hz)
	1	110	8.3 (-35° @ 2.5 Hz)

Gyroscope ODR [Hz]	LPF1_SEL_G	FTYPE[2:0]	Bandwidth [Hz] (phase delay @ 20 Hz)
26	1	111	8.3 (-35° @ 2.5 Hz)
52	0	-	16.7 (-35° @ 5 Hz)
	1	0xx	16.7 (-36° @ 5 Hz)
	1	100	16.7 (-39° @ 5 Hz)
	1	101	16.9 (-43° @ 5 Hz)
	1	110	13.4 (-44° @ 5 Hz)
	1	111	9.8 (-49° @ 5 Hz)
	104	0	-
1		0xx	33 (-38° @ 10 Hz)
1		100	34 (-43° @ 10 Hz)
1		101	31 (-51° @ 10 Hz)
1		110	19 (-54° @ 10 Hz)
1		111	11.6 (-64° @ 10 Hz)
208	0	-	67 (-35°)
	1	0xx	67 (-41°)
	1	100	62 (-51°)
	1	101	43 (-68°)
	1	110	23 (-74°)
	1	111	12.2 (-93°)
416	0	-	133 (-18°)
	1	000	133 (-23°)
	1	001	128 (-25°)
	1	010	112 (-28°)
	1	011	134 (-21°)
	1	100	86 (-34°)
	1	101	48 (-51°)
	1	110	24.6 (-57°)
	1	111	12.4 (-76°)
833	0	-	267 (-9°)
	1	000	222 (-14°)
	1	001	186 (-16°)
	1	010	140 (-20°)
	1	011	260 (-12°)
	1	100	96 (-25°)
	1	101	49 (-43°)
	1	110	25 (-48°)
	1	111	12.6 (-68°)
1667	0	-	539 (-5°)
	1	000	274 (-10°)
	1	001	212 (-12°)
	1	010	150 (-15°)
	1	011	390 (-8°)
	1	100	99 (-21°)
	1	101	50 (-38°)

Gyroscope ODR [Hz]	LPF1_SEL_G	FTYPE[2:0]	Bandwidth [Hz] (phase delay @ 20 Hz)
1667	1	110	25 (-44°)
	1	111	12.6 (-63°)

3.8 Gyroscope turn-on/off time

Turn-on/off time has to be considered also for the gyroscope sensor when switching its modes or when the gyroscope ODR is changed.

The maximum overall turn-on/off time (with HP filter disabled) in order to switch gyroscope power modes or gyroscope ODR is shown in Table 14. Gyroscope turn-on/off time (HP disabled).

Note: The gyroscope ODR timing is not impacted by power mode changes (the new configuration takes effect after the completion of the current period).

Table 14. Gyroscope turn-on/off time (HP disabled)

Starting mode	Target mode	Max turn-on/off time ⁽¹⁾
Power-down	Sleep	70 ms
Power-down	Low-power	70 ms + discard 1 sample
Power-down	High-performance	70 ms + see Table 15 or Table 16
Sleep	Low-power	Discard 1 sample
Sleep	High-performance	See Table 15 or Table 16
Low-power	High-performance	Discard 2 samples
Low-power	Low-power (ODR change)	Discard 1 sample
High-performance	Low-power	Discard 1 sample
High-performance	High-performance (ODR change)	Discard 2 samples
Low-power / high-performance	Power-down	1 μ s if both accelerometer and gyroscope in PD 300 μ s if accelerometer not in PD

1. Settling time @ 99% of the final value

Table 15. Gyroscope samples to be discarded (LPF1 disabled)

Gyroscope ODR [Hz]	Number of samples to be discarded ⁽¹⁾
12.5 Hz	2
26 Hz	3
52 Hz	3
104 Hz	3
208 Hz	3
416 Hz	3
833 Hz	3
1667 Hz	4

1. Settling time @ 99% of the final value

Table 16. Gyroscope chain settling time (LPF1 enabled)

FTYPE[2:0]	Maximum settling time @ each ODR [ms] ⁽¹⁾
000	3.5
001	4.8
010	6.9
011	2.1
100	11
101	22
110	30
111	60

1. Settling time @ 99% of the final value

When there is a mode change to high-performance mode and the HP filter is enabled, or the HP filter is turned on, the HP filter settling time must be added to [Table 14. Gyroscope turn-on/off time \(HP disabled\)](#). The HP filter settling time is independent from the ODR and is shown in [Table 12. Gyroscope digital HP filter cutoff selection](#).

4 Reading output data

4.1 Startup sequence

Once the device is powered up, it automatically downloads the calibration coefficients from the embedded flash to the internal registers. When the boot procedure is completed, that is, after approximately 10 milliseconds, the accelerometer and gyroscope automatically enter power-down mode.

To turn on the accelerometer and gather acceleration data through the I²C / MIPI I3CSM / SPI interface, it is necessary to select one of the operating modes through the CTRL1_XL register.

The following general-purpose sequence can be used to configure the accelerometer:

1. Write INT1_CTRL = 01h // Accelerometer data-ready interrupt on INT1
2. Write CTRL1_XL = 60h // Accelerometer = 416 Hz (high-performance mode)

To turn on the gyroscope and gather angular rate data through the I²C / MIPI I3CSM / SPI interface, it is necessary to select one of the operating modes through CTRL2_G.

The following general-purpose sequence can be used to configure the gyroscope:

1. Write INT1_CTRL = 02h // Gyroscope data-ready interrupt on INT1
2. Write CTRL2_G = 60h // Gyroscope = 416 Hz (high-performance mode)

4.2 Using the status register

The device is provided with a STATUS_REG register, which should be polled to check when a new set of data is available. The XLDA bit is set to 1 when a new set of data is available at the accelerometer output. The GDA bit is set to 1 when a new set of data is available at the gyroscope output.

For the accelerometer (the gyroscope is similar), the read of the output registers should be performed as follows:

1. Read STATUS_REG.
2. If XLDA = 0, then go to 1.
3. Read OUTX_L_A.
4. Read OUTX_H_A.
5. Read OUTY_L_A.
6. Read OUTY_H_A.
7. Read OUTZ_L_A.
8. Read OUTZ_H_A.
9. Data processing
10. Go to 1.

4.3 Using the data-ready signal

The device can be configured to have a hardware signal to determine when a new set of measurement data is available to be read.

For the accelerometer sensor, the data-ready signal is represented by the XLDA bit of the STATUS_REG register. The signal can be driven to the INT1 pin by setting the INT1_DRDY_XL bit of the INT1_CTRL register to 1 and to the INT2 pin by setting the INT2_DRDY_XL bit of the INT2_CTRL register to 1.

For the gyroscope sensor, the data-ready signal is represented by the GDA bit of the STATUS_REG register. The signal can be driven to the INT1 pin by setting the INT1_DRDY_G bit of the INT1_CTRL register to 1 and to the INT2 pin by setting the INT2_DRDY_G bit of the INT2_CTRL register to 1.

The data-ready signal rises to 1 when a new set of data has been generated and it is available to be read. The data-ready signal can be either latched or pulsed. If the dataready_pulsed bit of the COUNTER_BDR_REG1 register is set to 0 (default value), then the data-ready signal is latched and the interrupt is reset when the higher byte of one axis is read (29h, 2Bh, 2Dh for the accelerometer; 23h, 25h, 27h for the gyroscope). If the dataready_pulsed bit of the COUNTER_BDR_REG1 register is set to 1, then the data-ready is pulsed and the duration of the pulse observed on the interrupt pins is 75 μ s. Pulsed mode is not applied to the XLDA and GDA bits, which are always latched.

Figure 5. Data-ready signal

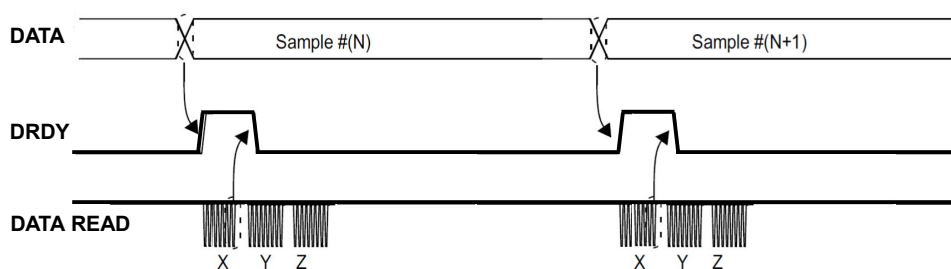

4.3.1 DRDY mask functionality

Setting the DRDY_MASK bit of the CTRL4_C register to 1, the accelerometer and gyroscope data-ready signals are masked until the settling of the sensor filters is completed.

When FIFO is active and the DRDY_MASK bit is set to 1, accelerometer/gyroscope invalid samples stored in FIFO can be equal to 7FFFh, 7FFEh or 7FFDh. In this way, a tag is applied to the invalid samples stored in the FIFO buffer so that they can be easily identified and discarded during data post-processing.

Note: The DRDY_MASK bit acts only on the accelerometer LPF1 digital filter settling time for every accelerometer ODR and on the gyroscope LPF2 digital filter settling time for gyroscope ODR \leq 833 Hz.

4.4 Using the block data update (BDU) feature

If reading the accelerometer/gyroscope data is not synchronized with either the XLDA/GDA bits in the STATUS_REG register or with the DRDY signal driven to the INT1/INT2 pins, it is strongly recommended to set the BDU (block data update) bit to 1 in the CTRL3_C register.

This feature avoids reading values (most significant and least significant bytes of the output data) related to different samples. In particular, when the BDU is activated, the data registers related to each axis always contain the most recent output data produced by the device, but, in case the read of a given pair (that is, OUTX_H_A(G) and OUTX_L_A(G), OUTY_H_A(G) and OUTY_L_A(G), OUTZ_H_A(G) and OUTZ_L_A(G)) is initiated, the refresh for that pair is blocked until both the MSB and LSB of the data are read.

Note: BDU only guarantees that the LSB and MSB have been sampled at the same moment. For example, if the reading speed is too slow, X and Y can be read at T1 and Z sampled at T2.

The BDU feature also acts on the FIFO_STATUS1 and FIFO_STATUS2 registers. When the BDU bit is set to 1, it is mandatory to read FIFO_STATUS1 first and then FIFO_STATUS2.

4.5 Understanding output data

The measured acceleration data are sent to the OUTX_H_A, OUTX_L_A, OUTY_H_A, OUTY_L_A, OUTZ_H_A, and OUTZ_L_A registers. These registers contain, respectively, the most significant byte and the least significant byte of the acceleration signals acting on the X, Y, and Z axes.

The measured angular rate data are sent to the OUTX_H_G, OUTX_L_G, OUTY_H_G, OUTY_L_G, OUTZ_H_G, and OUTZ_L_G registers. These registers contain, respectively, the most significant byte and the least significant byte of the angular rate signals acting on the X, Y, and Z axes.

The complete output data for the X, Y, Z channels is given by the concatenation OUTX_H_A(G) & OUTX_L_A(G), OUTY_H_A(G) & OUTY_L_A(G), OUTZ_H_A(G) & OUTZ_L_A(G) and it is expressed as a two's complement number.

Both acceleration data and angular rate data are represented as 16-bit numbers.

4.5.1 Examples of output data

Table 17. Content of output data registers vs. acceleration (FS_XL = $\pm 2 g$) provides a few basic examples of the accelerometer data that is read in the data registers when the device is subjected to a given acceleration.

Table 18. Content of output data registers vs. angular rate (FS_G = $\pm 250 dps$) provides a few basic examples of the gyroscope data that is read in the data registers when the device is subjected to a given angular rate.

The values listed in the following tables are given under the hypothesis of perfect device calibration (that is, no offset, no gain error, and so forth).

Table 17. Content of output data registers vs. acceleration (FS_XL = $\pm 2 g$)

Acceleration values	Register address	
	OUTX_H_A (29h)	OUTX_L_A (28h)
0 g	00h	00h
350 mg	16h	69h
1 g	40h	09h
-350 mg	E9h	97h
-1 g	BFh	F7h

Table 18. Content of output data registers vs. angular rate (FS_G = $\pm 250 dps$)

Angular rate values	Register address	
	OUTX_H_G (23h)	OUTX_L_G (22h)
0 dps	00h	00h
100 dps	2Ch	A4h
200 dps	59h	49h
-100 dps	D3h	5Ch
-200 dps	A6h	B7h

4.6 Accelerometer offset registers

The device provides accelerometer offset registers (X_OFS_USR, Y_OFS_USR, Z_OFS_USR) which can be used for zero-g offset correction or, in general, to apply an offset to the accelerometer output data.

The accelerometer offset block can be enabled by setting the USR_OFF_ON_OUT bit of the CTRL7_G register. The offset value set in the offset registers is internally subtracted from the measured acceleration value for the respective axis. Internally processed data are then sent to the accelerometer output register and to the FIFO (if enabled). These register values are expressed as an 8-bit word in two's complement and must be in the range [-127, 127].

The weight [g/LSB] to be applied to the offset register values is independent of the accelerometer selected full scale and can be configured using the USR_OFF_W bit of the CTRL6_C register:

- 2^{-10} g/LSB if the USR_OFF_W bit is set to 0
- 2^{-6} g/LSB if the USR_OFF_W bit is set to 1

4.7 Wraparound functions

The wraparound function can be used to auto address the device registers for a circular burst-mode read. Basically, with a multiple read operation, the address of the register that is being read goes automatically from the first register to the last register of the pattern and then goes back to the first one.

4.7.1 FIFO output registers

The wraparound function is automatically enabled when performing a multiple read operation of the FIFO output registers. After reading FIFO_DATA_OUT_Z_H (7Eh), the address of the next register that is read goes automatically back to FIFO_DATA_OUT_TAG (78h), allowing the user to read many data with a unique multiple read.

4.7.2 Sensor output registers

It is possible to apply the wraparound function to the other output registers.

The wraparound function can also be enabled for the following groups of output registers:

- Accelerometer output registers, from OUTX_L_A (28h) to OUTZ_H_A (2Dh)
- Gyroscope output registers, from OUTX_L_G (22h) to OUTZ_H_G (27h)
- Gyroscope and accelerometer output registers, from OUTX_L_G (22h) to OUTZ_H_A (2Dh)

The output register wraparound pattern can be configured using the bits ROUNDING[1:0] of the CTRL5_C register, as indicated in the following table.

Table 19. Output register wraparound pattern

ROUNDING[1:0]	Wraparound pattern
00	No wraparound
01	Accelerometer only
10	Gyroscope only
11	Gyroscope + accelerometer

4.8 DEN (data enable)

The device allows an external trigger level recognition by enabling the TRIG_EN, LVL1_EN, LVL2_EN bits in CTRL6_C register.

Four different modes can be selected (see [Table 20. DEN configurations](#)):

- Edge-sensitive trigger mode
- Level-sensitive trigger mode
- Level-sensitive latched mode
- Level-sensitive FIFO enable mode

The data enable (DEN) input signal must be driven on the INT2 pin, which is configured as an input pin when one of these modes is enabled.

The DEN functionality is active by default on the gyroscope data only. To extend this feature to the accelerometer data, the bit DEN_XL_EN in the CTRL9_XL register must be set to 1.

The DEN active level is low by default. It can be changed to active-high by setting the bit DEN_LH in the CTRL9_XL register to 1.

Table 20. DEN configurations

TRIG_EN	LVL1_EN	LVL2_EN	Function	Trigger type	Action
0	0	0	Data enable off	-	-
1	0	0	Edge-sensitive trigger mode	Edge	Data generation
0	1	0	Level-sensitive trigger mode	Level	Data stamping
0	1	1	Level-sensitive latched mode	Edge	Data stamping
1	1	0	Level-sensitive FIFO enable mode	Level	Data generation in FIFO and stamping

4.8.1 Edge-sensitive trigger mode

Edge-sensitive trigger mode can be enabled by setting the TRIG_EN bit in CTRL6_C to 1, and the LVL1_EN, LVL2_EN bits in the CTRL6_C register to 0.

Once the edge-sensitive trigger mode is enabled, the FIFO buffer and output registers are filled with the first sample acquired after every rising edge (if DEN_LH bit is equal to 1) or falling edge (if DEN_LH bit is equal to 0) of the DEN input signal.

The following figure shows, with red circles, the samples acquired after the falling edges (DEN active-low).

Figure 6. Edge-sensitive trigger mode, DEN active-low

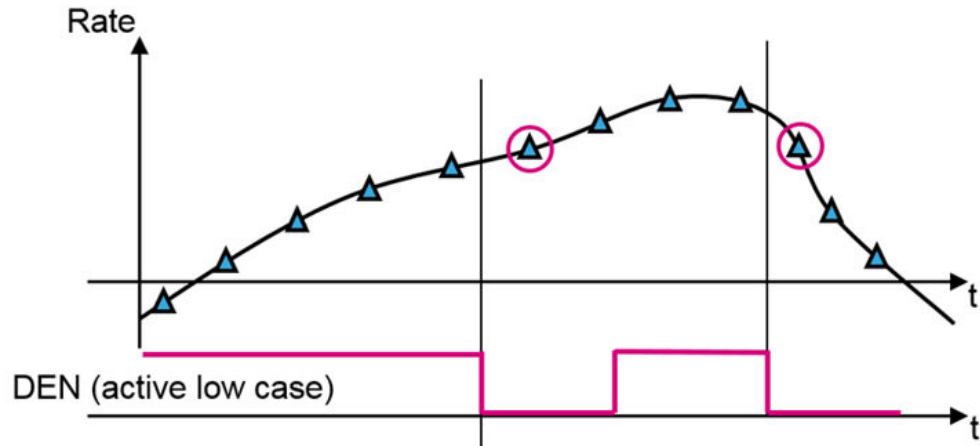

Edge-sensitive trigger mode, when enabled, acts only on the gyroscope output registers. GDA is related only to downsampled data, while the accelerometer output registers and XLDA are updated according to ODR_XL. If the DEN_XL_EN bit is set to 1, the accelerometer sensor is downsampled too. In this case, the gyroscope and accelerometer have to be set in combo mode at the same ODR. The accelerometer standalone mode can be used by setting the gyroscope in power-down.

Note that the DEN level is internally read just before the update of the data registers. If a level change occurs after the read, DEN is acknowledged at the next ODR.

There are three possible configurations for the edge-sensitive trigger in FIFO, described below:

1. Only the gyroscope in trigger mode but not saved in FIFO. In this case, FIFO is related only to the accelerometer and works as usual.
2. Only the gyroscope in trigger mode and saved in FIFO. In this configuration, there are the following limitations in FIFO:
 - Gyroscope batch data rate (BDR_GY_[3:0] bits of the FIFO_CTRL3 register) and gyroscope output data rate (ODR_G[3:0] of the CTRL2_G register) must be set to the same value.
 - Configuration-change sensor (CFG-change) is not allowed (ODRCHG_EN bit of the FIFO_CTRL2 register must be set to 0).
 - Timestamp decimation in FIFO is not allowed (DEC_TS_BATCH_[1:0] bits of the FIFO_CTRL4 register must be set to 00).
3. Gyroscope and accelerometer in trigger mode and saved in FIFO. In this configuration there are the following limitations in FIFO:
 - Gyroscope batch data rate (BDR_GY_[3:0] bits of the FIFO_CTRL3 register) and gyroscope output data rate (ODR_G[3:0] of CTRL2_G register) must be set to the same value.
 - Accelerometer batch data rate (BDR_XL_[3:0] bits of the FIFO_CTRL3 register) and accelerometer output data rate (ODR_XL[3:0] of the CTRL1_XL register) must be set to the same value.
 - Gyroscope and accelerometer must be set at the same output data rate, or the gyroscope must be configured in power-down mode.
 - Configuration-change sensor (CFG-change) is not allowed (ODRCHG_EN bit of the FIFO_CTRL2 register must be set to 0).
 - Timestamp decimation in FIFO is not allowed (DEC_TS_BATCH_[1:0] bits of the FIFO_CTRL4 register must be set to 00).

Edge-sensitive trigger mode allows, for example, the synchronization of the camera frames with the samples coming from the gyroscope for electrical image stabilization (EIS) applications. The synchronization signal from the camera module must be connected to the INT2 pin.

In the example shown below, the FIFO has been configured to store both the gyroscope data and the accelerometer data in the FIFO buffer. When the DEN signal toggles, the data are written to FIFO on the falling edge.

1. Write 44h to FIFO_CTRL3 // Enable accelerometer and gyroscope in FIFO @ 104 Hz
2. Write 06h to FIFO_CTRL4 // Set FIFO in continuous mode
// Enable the edge-sensitive trigger
3. Write 80h to CTRL6_C // INT2 pin is switched to input mode (DEN signal)
4. Write E8h to CTRL9_XL // Extend DEN functionality to accelerometer sensor
// Select DEN active level (active low)
5. Write 40h to CTRL1_XL // Turn on the accelerometer: ODR_XL = 104 Hz, FS_XL = $\pm 2 g$
6. Write 4Ch to CTRL2_G // Turn on the gyroscope: ODR_G = 104 Hz, FS_G = $\pm 2000 dps$

4.8.2 Level-sensitive trigger mode

Level-sensitive trigger mode can be enabled by setting the LVL1_EN bit in the CTRL6_C register to 1, and the TRIG_EN, LVL2_EN bits in the CTRL6_C register to 0.

Once the level-sensitive trigger mode is enabled, the LSB bit of the selected data (in output registers and FIFO) is replaced by 1 if the DEN level is active, or 0 if the DEN level is not active. The selected data can be the X, Y, Z axes of the accelerometer or gyroscope sensor (see Section 4.8.5: LSB selection for DEN stamping for details).

All data can be stored in the FIFO according to the FIFO settings.

Note that the DEN level is internally read just before the update of the data registers. If a level change occurs after the read, DEN is acknowledged at the next ODR.

If the DEN feature is enabled on the accelerometer sensor by asserting the DEN_XL_EN bit of the CTRL9_XL register, the accelerometer and gyroscope sensors must be configured at the same ODR or the gyroscope must be set in power-down mode.

Figure 7 shows with red circles the samples stored in the FIFO with LSB = 0 (DEN not active) and with blue circles the samples stored in the FIFO with LSB = 1 (DEN active).

Figure 7. Level-sensitive trigger mode, DEN active-low

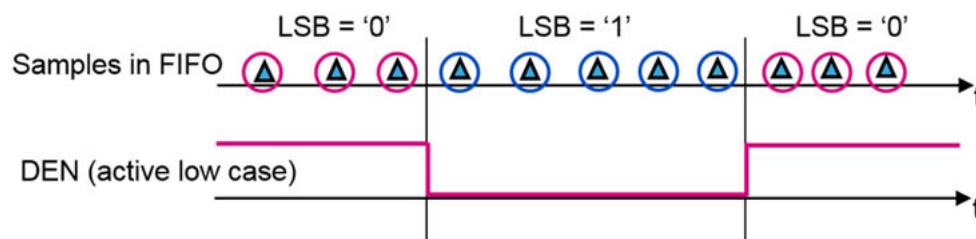

When the level-sensitive trigger mode is enabled, the DEN signal can also be used to filter the data-ready signal on the INT1 pin. INT1 shows data-ready information only when the DEN pin is in the active state. To do this, the bit DEN_DRDY_flag of the INT1_CTRL register must be set to 1. The interrupt signal can be latched or pulsed according to the dataready_pulsed bit of the COUNTER_BDR_REG1 register.

Figure 8 shows an example of data-ready on INT1 when the DEN level is low (active state).

Figure 8. Level-sensitive trigger mode, DEN active-low, DEN_DRDY on INT1

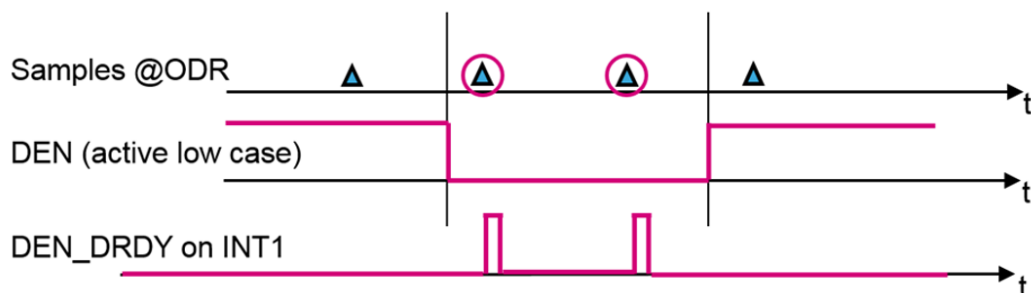

4.8.3 Level-sensitive latched mode

Level-sensitive latched mode can be enabled by setting the LVL1_EN and LVL2_EN bits in the CTRL6_C register to 1, and the TRIG_EN bit in the CTRL6_C register to 0.

When the level-sensitive latched mode is enabled, the LSB bit of the selected data (in output registers and FIFO) is normally set to 0 and becomes 1 only on the first sample after a pulse on the DEN pin.

Note that the DEN level is internally read just before the update of the data registers. If a level change occurs after the read, DEN is acknowledged at the next ODR.

If the DEN feature is enabled on the accelerometer sensor by asserting the DEN_XL_EN bit of the CTRL9_XL register, the accelerometer and gyroscope sensors must be configured at the same ODR or the gyroscope must be set in power-down mode.

Data can be selected through the DEN_X, DEN_Y, DEN_Z, DEN_XL_G bits in CTRL9_XL (see Section 4.8.5: LSB selection for DEN stamping for details).

Figure 9 shows an example of level-sensitive latched mode with DEN active-low. After the pulse on the DEN pin, the sample with a red circle has the value 1 on the LSB bit. All the other samples have LSB bit 0.

Figure 9. Level-sensitive latched mode, DEN active-low

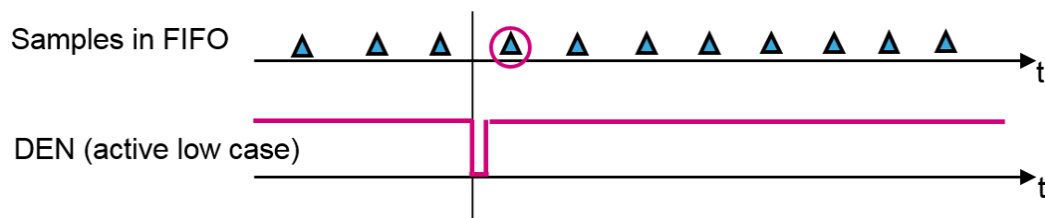

When the level-sensitive latched mode is enabled and the bit DEN_DRDY_flag of the INT1_CTRL register is set to 1, a pulse is generated on the INT1 pin corresponding to the availability of the first sample generated after the DEN pulse occurrence (see Figure 10).

Figure 10. Level-sensitive latched mode, DEN active-low, DEN_DRDY on INT1

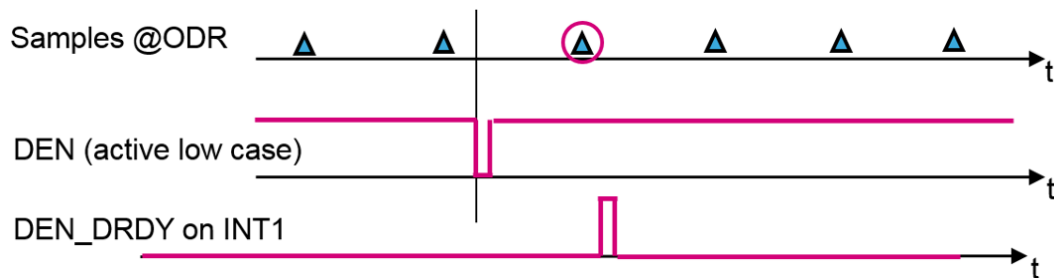

4.8.4 Level-sensitive FIFO enable mode

Level-sensitive FIFO enable mode can be enabled by setting the TRIG_EN and LVL1_EN bits in the CTRL6_C register to 1, and the LVL2_EN bit in the CTRL6_C register to 0.

Once the level-sensitive FIFO enable mode is enabled, data is stored in the FIFO only when the DEN pin is equal to the active state.

In this mode, the LSB bit of the selected data (in output registers and FIFO) is replaced by 0 for odd DEN events and by 1 for even DEN events. This feature allows distinguishing the data stored in FIFO during the current DEN active window from the data stored in FIFO during the next DEN active window.

Note that the DEN level is internally read just before the update of the data registers. If a level change occurs after the reading, DEN is acknowledged at the next ODR.

If the DEN feature is enabled on the accelerometer sensor by asserting the DEN_XL_EN bit of the CTRL9_XL register, the accelerometer and gyroscope sensors must be configured at the same ODR or the gyroscope must be set in power-down mode.

The selected data can be the X, Y, Z axes of the accelerometer or gyroscope sensor. Data can be selected through the DEN_X, DEN_Y, DEN_Z, DEN_XL_G bits in the CTRL9_XL register (see [Section 4.8.5: LSB selection for DEN stamping](#) for details).

An example of level-sensitive FIFO enable mode is shown in [Figure 11](#). The red circles show the samples stored in the FIFO with LSB bit 0, while the blue circles show the samples with LSB bit 1.

Figure 11. Level-sensitive FIFO enable mode, DEN active-low

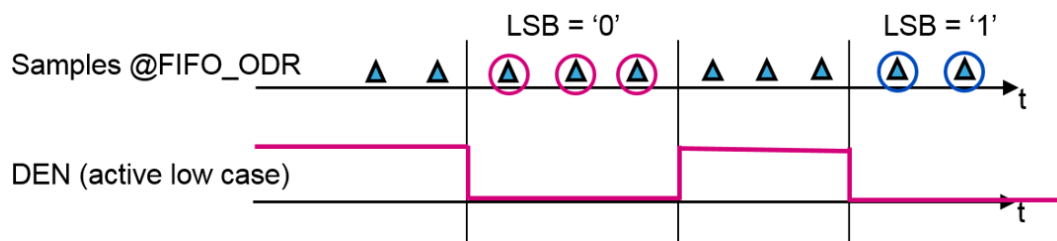

When using level-sensitive FIFO enabled mode, some limitations must be taken into account in the FIFO configuration:

- Gyroscope batch data rate (BDR_GY_[3:0] bits of the FIFO_CTRL3 register) and gyroscope output data rate (ODR_G[3:0] of the CTRL2_G register) must be set to the same value.
- Accelerometer batch data rate (BDR_XL_[3:0] bits of the FIFO_CTRL3 register) and accelerometer output data rate (ODR_XL[3:0] of the CTRL1_XL register) must be set to the same value if the DEN_XL_EN bit of the CTRL9_XL register is set to 1.
- Configuration-change sensor (CFG-change) is not allowed (ODRCHG_EN bit of the FIFO_CTRL2 register must be set to 0).
- Timestamp decimation in FIFO is not allowed (DEC_TS_BATCH_[1:0] bits of the FIFO_CTRL4 register must be set to 00).

4.8.5 LSB selection for DEN stamping

When level-sensitive modes (trigger or latched) are used, it is possible to select which LSB have to contain the information related to DEN pin behavior. This information can be stamped on the accelerometer or gyroscope axes in accordance with bits DEN_X, DEN_Y, DEN_Z and DEN_XL_G of the CTRL9_XL register. Setting to 1 the DEN_X, DEN_Y, DEN_Z bits, DEN information is stamped in the LSB of the corresponding axes of the sensor selected with the DEN_XL_G bit. By setting DEN_XL_G to 0, the DEN information is stamped in the selected gyroscope axes, while by setting DEN_XL_G to 1, the DEN information is stamped in the selected accelerometer axes.

By default, the bits are configured to have information on all the gyroscope axes.

5 Interrupt generation

Interrupt generation is based on accelerometer data only, so, for interrupt-generation purposes, the accelerometer sensor has to be set in an active operating mode (not in power-down). The gyroscope sensor can be configured in power-down mode since it's not involved in interrupt generation.

The interrupt generator can be configured to detect:

- Free-fall
- Wake-up
- 6D/4D orientation detection
- Activity/inactivity and motion/stationary recognition

Moreover, the device can be configured to generate interrupt signals activated by user-defined motion patterns. To do this, up to 16 embedded finite state machines can be programmed independently for motion detection such as vehicle status (stationary or moving), anti-theft alarm, and shock detection. Furthermore, up to 8 decision trees can simultaneously and independently run inside the machine learning core logic.

The embedded finite state machine and the machine learning core features offer very high customization capabilities starting from scratch or importing activity detection programs directly provided by STMicroelectronics. Refer to the finite state machine application note and the machine learning core application note available on www.st.com.

All these interrupt signals, together with the FIFO interrupt signals, can be independently driven to the INT1 and INT2 interrupt pins or checked by reading the dedicated source register bits.

When MIPI I3CSM interface is used, information about the feature triggering the interrupt event is contained in the in-band interrupt (IBI) frame as described in the datasheet.

The H_LACTIVE bit of the CTRL3_C register must be used to select the polarity of the interrupt pins. If this bit is set to 0 (default value), the interrupt pins are active high and they change from low to high level when the related interrupt condition is verified. Otherwise, if the H_LACTIVE bit is set to 1 (active low), the interrupt pins are normally at high level and they change from high to low when the interrupt condition is reached.

The PP_OD bit of CTR3_C allows changing the behavior of the interrupt pins from push-pull to open drain. If the PP_OD bit is set to 0, the interrupt pins are in push-pull configuration (low-impedance output for both high and low level). When the PP_OD bit is set to 1, only the interrupt active state is a low-impedance output.

5.1 Interrupt pin configuration

The device is provided with two pins that can be activated to generate either data-ready or interrupt signals. The functionality of these pins is selected through the MD1_CFG and INT1_CTRL registers for the INT1 pin, and through the MD2_CFG and INT2_CTRL registers for the INT2 pin.

A brief description of these interrupt control registers is given in the following summary. The default value of their bits is equal to 0, which corresponds to 'disable'. In order to enable routing a specific interrupt signal to the pin, the related bit has to be set to 1.

Table 21. INT1_CTRL register

b7	b6	b5	b4	b3	b2	b1	b0
DEN_DRDY_flag	INT1_CNT_BDR	INT1_FIFO_FULL	INT1_FIFO_OVR	INT1_FIFO_TH	INT1_BOOT	INT1_DRDY_G	INT1_DRDY_XL

- DEN_DRDY_flag: DEN_DRDY flag interrupt on INT1
- INT1_CNT_BDR: FIFO COUNTER_BDR_IA interrupt on INT1
- INT1_FIFO_FULL: FIFO full flag interrupt on INT1
- INT1_FIFO_OVR: FIFO overrun flag interrupt on INT1
- INT1_FIFO_TH: FIFO threshold interrupt on INT1
- INT1_BOOT: boot interrupt on INT1
- INT1_DRDY_G: gyroscope data-ready on INT1
- INT1_DRDY_XL: accelerometer data-ready on INT1

Table 22. MD1_CFG register

b7	b6	b5	b4	b3	b2	b1	b0
INT1_SLEEP_CHANGE	0	INT1_WU	INT1_FF	0	INT1_6D	INT1_EMB_FUNC	0

- INT1_SLEEP_CHANGE: activity/inactivity recognition event interrupt on INT1
- INT1_WU: wake-up interrupt on INT1
- INT1_FF: free-fall interrupt on INT1
- INT1_6D: 6D detection interrupt on INT1
- INT1_EMB_FUNC: embedded functions interrupt on INT1 (refer to [Section 6: Timestamp](#) for more details).

Table 23. INT2_CTRL register

b7	b6	b5	b4	b3	b2	b1	b0
0	INT2_CNT_BDR	INT2_FIFO_FULL	INT2_FIFO_OVR	INT2_FIFO_TH	INT2_DRDY_TEMP	INT2_DRDY_G	INT2_DRDY_XL

- INT2_CNT_BDR: FIFO COUNTER_BDR_IA interrupt on INT2
- INT2_FIFO_FULL: FIFO full flag interrupt on INT2
- INT2_FIFO_OVR: FIFO overrun flag interrupt on INT2
- INT2_FIFO_TH: FIFO threshold interrupt on INT2
- INT2_DRDY_TEMP: temperature data-ready on INT2
- INT2_DRDY_G: gyroscope data-ready on INT2
- INT2_DRDY_XL: accelerometer data-ready on INT2

Table 24. MD2_CFG register

b7	b6	b5	b4	b3	b2	b1	b0
INT2_SLEEP_CHANGE	0	INT2_WU	INT2_FF	0	INT2_6D	INT2_EMB_FUNC	INT2_TIMESTAMP

- INT2_SLEEP_CHANGE: activity/inactivity recognition event interrupt on INT2
- INT2_WU: wake-up interrupt on INT2
- INT2_FF: free-fall interrupt on INT2
- INT2_6D: 6D detection interrupt on INT2
- INT2_EMB_FUNC: embedded functions interrupt on INT2 (refer to [Section 6: Timestamp](#) for more details).
- INT2_TIMESTAMP: timestamp overflow alert interrupt on INT2

If multiple interrupt signals are routed to the same pin (INTx), the logic level of this pin is the “OR” combination of the selected interrupt signals. In order to know which event has generated the interrupt condition, the related source registers have to be read:

- WAKE_UP_SRC and D6D_SRC (basic interrupt functions)
- STATUS_REG (for data-ready signals)
- EMBD_FUNC_STATUS_MAINPAGE / EMB_FUNC_SRC (for embedded functions)
- FSM_STATUS_A_MAINPAGE / FSM_STATUS_A and FSM_STATUS_B_MAINPAGE / FSM_STATUS_B (for finite state machine)
- FIFO_STATUS2 (for FIFO)

The ALL_INT_SRC register groups the basic interrupts functions event status (6D/4D, free-fall, wake-up, activity/inactivity) in a single register. It is possible to read this register in order to address a subsequent specific source register read.

The INT2_on_INT1 bit of the CTRL4_C register allows driving all the enabled interrupt signals in logic “OR” on the INT1 pin (by setting this bit to 1). When this bit is set to 0, the interrupt signals are divided between the INT1 and INT2 pins.

The basic interrupts have to be enabled by setting the INTERRUPTS_ENABLE bit in the INT_CFG1 register. The LIR bit of the INT_CFG0 register enables the latched interrupt for the basic interrupt functions. When this bit is set to 1 and the interrupt flag is sent to the INT1 pin and/or INT2 pin, the interrupt remains active until the ALL_INT_SRC register or the corresponding source register is read, and it is reset at the next ODR cycle. The latched interrupt is enabled on a function only if a function is routed to the INT1 or INT2 pin. If latched mode is enabled but the interrupt signal is not driven to the interrupt pins, the latch feature does not take effect.

Note: If latched mode is enabled (LIR = 1), it is not recommended to continuously poll the ALL_INT_SRC or the dedicated source registers, because by reading them the embedded functions are internally reset. A synchronous (with interrupt event) read of the source registers is recommended in this case.

When latched mode is enabled (LIR = 1), it is possible to force the immediate reset of the interrupt signal routed to the INT1 or INT2 pin and its corresponding interrupt status bit when ALL_INT_SRC (or the related source register) is read. In order to perform this immediate reset, the INT_CLR_ON_READ bit of the INT_CFG0 register must be set to 1. When bit INT_CLR_ON_READ is equal to 0, the reset occurs at the next ODR cycle.

5.2 Free-fall interrupt

Free-fall detection refers to a specific register configuration that allows recognizing when the device is in free-fall: the acceleration measured along all the axes goes to zero. In a real case a “free-fall zone” is defined around the zero-g level where all the accelerations are small enough to generate the interrupt. Configurable threshold and duration parameters are associated to free-fall event detection. The threshold parameter defines the free-fall zone amplitude. The duration parameter defines the minimum duration of the free-fall interrupt event to be recognized (Figure 12. Free-fall interrupt).

Figure 12. Free-fall interrupt

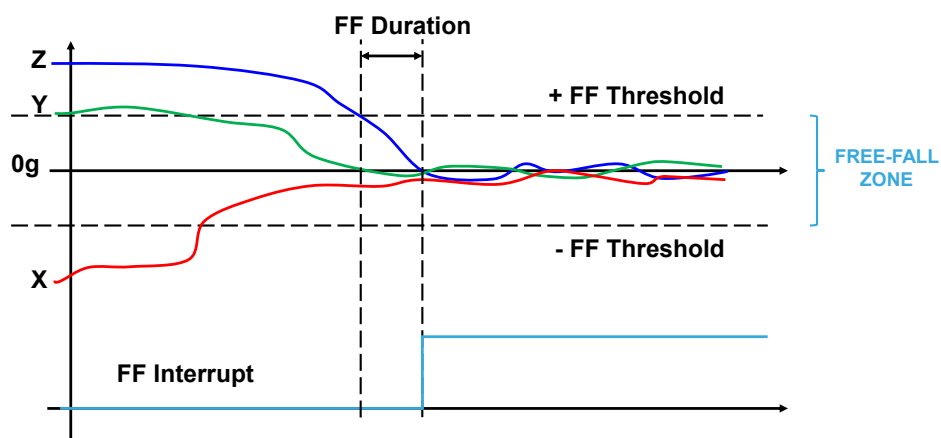

The free-fall interrupt signal can be enabled by setting the `INTERRUPTS_ENABLE` bit in the `INT_CFG1` register to 1 and can be driven to the two interrupt pins by setting the `INT1_FF` bit of the `MD1_CFG` register to 1 or the `INT2_FF` bit of the `MD2_CFG` register to 1. It can also be checked by reading the `FF_IA` bit of the `WAKE_UP_SRC` register.

If latched mode is disabled (`LIR` bit of `INT_CFG0` is set to 0), the interrupt signal is automatically reset when the free-fall condition is no longer verified. If latched mode is enabled and the free-fall interrupt signal is driven to the interrupt pins, once a free-fall event has occurred and the interrupt pin is asserted, it must be reset by reading the `WAKE_UP_SRC` or `ALL_INT_SRC` register. If latched mode is enabled but the interrupt signal is not driven to the interrupt pins, the latch feature does not take effect.

The `FREE_FALL` register is used to configure the threshold parameter. The unsigned threshold value is related to the value of the `FF_THS[2:0]` field value as indicated in Table 25. Free-fall threshold LSB value. The values given in this table are valid for each accelerometer full-scale value.

Table 25. Free-fall threshold LSB value

FREE_FALL - FF_THS[2:0]	Threshold LSB value [mg]
000	156
001	219
010	250
011	312
100	344
101	406
110	469
111	500

Duration time is measured in N/ODR_{XL} , where N is the content of the `FF_DUR[5:0]` field of the `FREE_FALL / WAKE_UP_DUR` registers and `ODR_XL` is the accelerometer data rate.

A basic software routine for free-fall event recognition is given below.

1. Write 60h to CTRL1_XL // Turn on the accelerometer
// ODR_XL = 416 Hz, FS_XL = ±2 g
2. Write 41h to INT_CFG0 // Enable latched mode with reset on read
3. Write 80h to INT_CFG1 // Enable interrupt function
4. Write 00h to WAKE_UP_DUR // Set event duration (FF_DUR5 bit)
5. Write 33h to FREE_FALL // Set FF threshold (FF_THS[2:0] = 011)
// Set six samples event duration (FF_DUR[5:0] = 000110)
6. Write 10h to MD1_CFG // FF interrupt driven to INT1 pin

The sample code exploits a threshold set to 312 mg for free-fall recognition and the event is notified by hardware through the INT1 pin. The FF_DUR[5:0] field of the FREE_FALL / WAKE_UP_DUR registers is configured like this to ignore events that are shorter than $6/ODR_XL = 6/412 \text{ Hz} \approx 15 \text{ msec}$ in order to avoid false detections

5.3 Wake-up interrupt

The wake-up feature can be implemented using either the slope filter (see [Section 3.5.1: Accelerometer slope filter](#) for more details) or the high-pass digital filter, as illustrated in [Figure 2. Accelerometer filtering chain](#). The filter to be applied can be selected using the SLOPE_FDS bit of the INT_CFG0 register. If this bit is set to 0 (default value), the slope filter is used. If it is set to 1, the HPF digital filter is used. Moreover, it is possible to configure the wake-up feature as an absolute wake-up with respect to a programmable position. This can be done by setting both the SLOPE_FDS bit of the INT_CFG0 register and the USR_OFF_ON_WU bit of the WAKE_UP_THS register to 1. Using this configuration, the input data for the wake-up function comes from the low-pass filter path and the programmable position is subtracted as an offset. The programmable position can be configured through the X_OFS_USR, Y_OFS_USR and Z_OFS_USR registers (refer to [Section 4.6: Accelerometer offset registers](#) for more details).

The wake-up interrupt signal is generated if a certain number of consecutive filtered data exceed the configured threshold ([Figure 13. Wake-up interrupt \(using the slope filter\)](#)).

The unsigned threshold value is defined using the WK_THS[5:0] bits of the WAKE_UP_THS register. The value of 1 LSB of these 6 bits depends on the selected accelerometer full scale and on the value of the WAKE_THS_W bit of the WAKE_UP_DUR register:

- If WAKE_THS_W = 0, 1 LSB = $FS_XL / 2^6$.
- If WAKE_THS_W = 1, 1 LSB = $FS_XL / 2^8$.

The threshold is applied to both positive and negative data. For wake-up interrupt generation, the absolute value of the filtered data must be bigger than the threshold.

The duration parameter defines the minimum duration of the wake-up event to be recognized. Its value is set using the WAKE_DUR[1:0] bits of the WAKE_UP_DUR register: 1 LSB corresponds to $1/ODR_XL$ time, where ODR_XL is the accelerometer output data rate. It is important to appropriately define the duration parameter to avoid unwanted wake-up interrupts due to spurious spikes of the input signal.

This interrupt signal can be enabled by setting the INTERRUPTS_ENABLE bit in the INT_CFG1 register to 1 and can be driven to the two interrupt pins by setting to 1 the INT1_WU bit of the MD1_CFG register or the INT2_WU bit of the MD2_CFG register. It can also be checked by reading the WU_IA bit of the WAKE_UP_SRC or ALL_INT_SRC register. The X_WU, Y_WU, Z_WU bits of the WAKE_UP_SRC register indicate which axes have triggered the wake-up event.

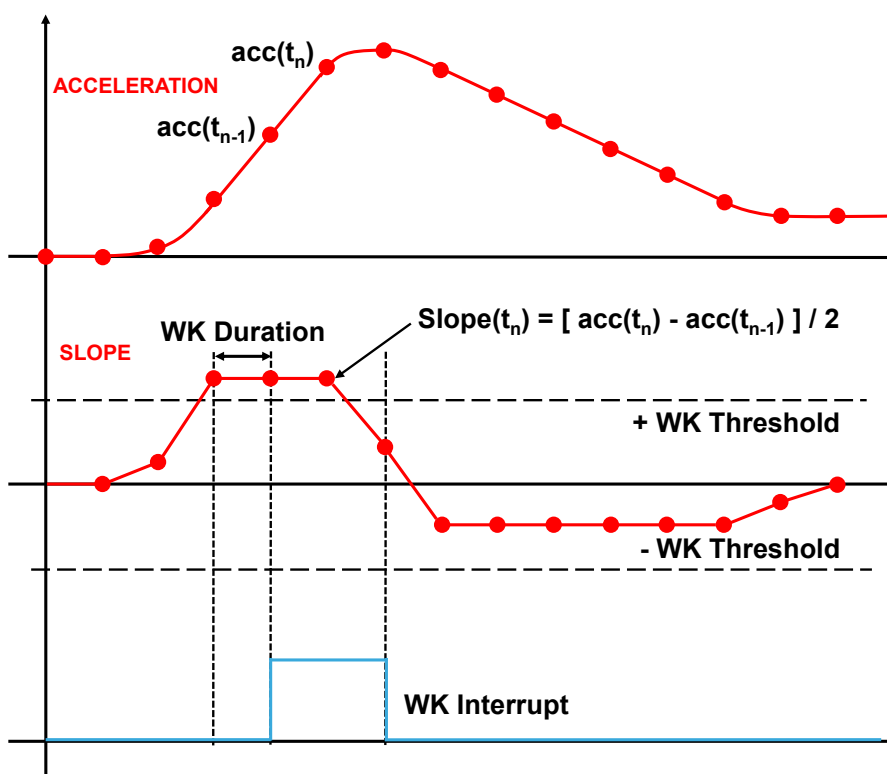
Figure 13. Wake-up interrupt (using the slope filter)

If latched mode is disabled (LIR bit of INT_CFG0 is set to 0), the interrupt signal is automatically reset when the filtered data falls below the threshold. If latched mode is enabled and the wake-up interrupt signal is driven to the interrupt pins, once a wake-up event has occurred and the interrupt pin is asserted, it must be reset by reading the WAKE_UP_SRC register or the ALL_INT_SRC register. The X_WU, Y_WU, Z_WU bits are maintained at the state in which the interrupt was generated until the read is performed, and released at the next ODR cycle. In case the WU_X, WU_Y, WU_Z bits have to be evaluated (in addition to the WU_IA bit), it is recommended to directly read the WAKE_UP_SRC register (do not use ALL_INT_SRC register for this specific case). If latched mode is enabled but the interrupt signal is not driven to the interrupt pins, the latch feature does not take effect. A basic software routine for wake-up event recognition using the high-pass digital filter is given below.

1. Write 60h to CTRL1_XL // Turn on the accelerometer
// ODR_XL = 416 Hz, FS_XL = ±2 g
2. Write 51h to INT_CFG0 // Enable latched mode with reset on read and digital high-pass filter
3. Write 80h to INT_CFG1 // Enable interrupt function
4. Write 00h to WAKE_UP_DUR // No duration and selection of wake-up threshold weight (1 LSB = FS_XL / 2⁶)
5. Write 02h to WAKE_UP_THS // Set wake-up threshold
6. Write 20h to MD1_CFG // Wake-up interrupt driven to INT1 pin

Since the duration time is set to zero, the wake-up interrupt signal is generated for each X,Y,Z filtered data exceeding the configured threshold. The WK_THS field of the WAKE_UP_THS register is set to 000010, therefore the wake-up threshold is 62.5 mg (= 2 * FS_XL / 2⁶).

If the wake-up functionality is implemented using the slope/high-pass digital filter, it is necessary to consider the settling time of the filter just after this functionality is enabled. For example, when using the slope filter (but a similar consideration can be done for the high-pass digital filter usage) the wake-up functionality is based on the comparison of the threshold value with half of the difference of the acceleration of the current (x,y,z) sample and the previous one (refer to [Section 3.5.1: Accelerometer slope filter](#)).

At the very first sample, the slope filter output is calculated as half of the difference of the current sample [for example, (x,y,z) = (0,0,1g)] with the previous one which is (x,y,z) = (0,0,0) since it doesn't exist. For this reason, on the z-axis, the first output value of the slope filter is $(1g - 0)/2 = 500 \text{ mg}$ and it could be higher than the threshold value in which case a spurious interrupt event is generated. The interrupt signal is kept high for 1 ODR then it goes low.

In order to avoid this spurious interrupt generation, multiple solutions are possible. Hereafter are three alternative solutions (for the slope filter case):

- a. Ignore the first generated wake-up signal.
- b. Add a wait time higher than 1 ODR before driving the interrupt signal to the INT1/2 pin.
- c. Initially set a higher ODR (833 Hz) so the first two samples are generated in a shorter period of time, reducing the slope filter latency time, then set the desired ODR (for example, 12.5 Hz) and drive the interrupt signal on the pin, as indicated in the procedure below:

1. Write 00h to WAKE_UP_DUR // No duration and selection of wake-up threshold weight (1 LSB = $FS_{XL} / 2^6$)
2. Write 02h to WAKE_UP_THS // Set wake-up threshold
3. Write 51h to INT_CFG0 // Enable interrupts and apply slope filter; latched mode disabled
4. Write 80h to INT_CFG1 // Enable interrupt function
5. Write 70h to CTRL1_XL // Turn on the accelerometer
// $ODR_{XL} = 833 \text{ Hz}$, $FS_{XL} = \pm 2 \text{ g}$
6. Wait 4 ms // Insert (reduced) wait time
7. Write 10h to CTRL1_XL // $ODR_{XL} = 12.5 \text{ Hz}$
8. Write 20h to MD1_CFG // Wake-up interrupt driven to INT1 pin

5.4 6D/4D orientation detection

The device provides the capability to detect the orientation of the device in space, enabling easy implementation of energy-saving procedures and automatic image rotation for mobile devices.

5.4.1 6D orientation detection

Six orientations of the device in space can be detected. The interrupt signal is asserted when the device switches from one orientation to another. The interrupt is not re-asserted as long as the position is maintained.

6D interrupt is generated when, for two consecutive samples, only one axis exceeds a selected threshold and the acceleration values measured from the other two axes are lower than the threshold. The ZH, ZL, YH, YL, XH, XL bits of the D6D_SRC register indicate which axis has triggered the 6D event.

In more detail:

Table 26. D6D_SRC register

b7	b6	b5	b4	b3	b2	b1	b0
DEN_DRDY	D6D_IA	ZH	ZL	YH	YL	XH	XL

- D6D_IA is set high when the device switches from one orientation to another.
- ZH (YH, XH) is set high when the face perpendicular to the Z (Y, X) axis is almost flat and the acceleration measured on the Z (Y, X) axis is positive and in the absolute value bigger than the threshold.
- ZL (YL, XL) is set high when the face perpendicular to the Z (Y, X) axis is almost flat and the acceleration measured on the Z (Y, X) axis is negative and in the absolute value bigger than the threshold.

The SIXD_THS[1:0] bits of the THS_6D register are used to select the threshold value used to detect the change in device orientation. The threshold values given in the following table are valid for each accelerometer full-scale value.

Table 27. Threshold for 4D/6D function

SIXD_THS[1:0]	Threshold value [degrees]
00	80
01	70
10	60
11	50

The low-pass filter LPF2 can also be used in 6D functionality by setting the LOW_PASS_ON_6D bit of the CTRL8_XL register to 1.

This interrupt signal can be enabled by setting the INTERRUPTS_ENABLE bit in the INT_CFG1 register to 1 and can be driven to the two interrupt pins by setting to 1 the INT1_6D bit of the MD1_CFG register or the INT2_6D bit of the MD2_CFG register. It can also be checked by reading the D6D_IA bit of the D6D_SRC register.

If latched mode is disabled (LIR bit of INT_CFG0 is set to 0), the interrupt signal is active only for 1/ODR_XL[s] then it is automatically disserted (ODR_XL is the accelerometer output data rate). If latched mode is enabled and the 6D interrupt signal is driven to the interrupt pins, once an orientation change has occurred and the interrupt pin is asserted, a read of the D6D_SRC or ALL_INT_SRC register clears the request and the device is ready to recognize a different orientation. The XL, XH, YL, YH, ZL, ZH bits are not affected by the LIR configuration. They correspond to the current state of the device when the D6D_SRC register is read. If latched mode is enabled but the interrupt signal is not driven to the interrupt pins, the latch feature does not take effect.

Referring to the six possible cases illustrated in Figure 14. 6D recognized orientations, the content of the D6D_SRC register for each position is shown in Table 28. D6D_SRC register in 6D positions.

Figure 14. 6D recognized orientations

Table 28. D6D_SRC register in 6D positions

Case	D6D_IA	ZH	ZL	YH	YL	XH	XL
(a)	1	0	0	1	0	0	0
(b)	1	0	0	0	0	0	1
(c)	1	0	0	0	0	1	0
(d)	1	0	0	0	1	0	0
(e)	1	1	0	0	0	0	0
(f)	1	0	1	0	0	0	0

A basic software routine for 6D orientation detection is as follows.

- Write 60h to CTRL1_XL // Turn on the accelerometer
// ODR_XL = 416 Hz, FS_XL = ± 2 g
- Write 41h to INT_CFG0 // Enable latched mode with reset on read
- Write 80h to INT_CFG1 // Enable interrupt function
- Write 40h to THS_6D // Set 6D threshold (SIXD_THS[1:0] = 10 = 60 degrees)
- Write 01h to CTRL8_XL // Enable LPF2 filter to 6D functionality
- Write 04h to MD1_CFG // 6D interrupt driven to INT1 pin

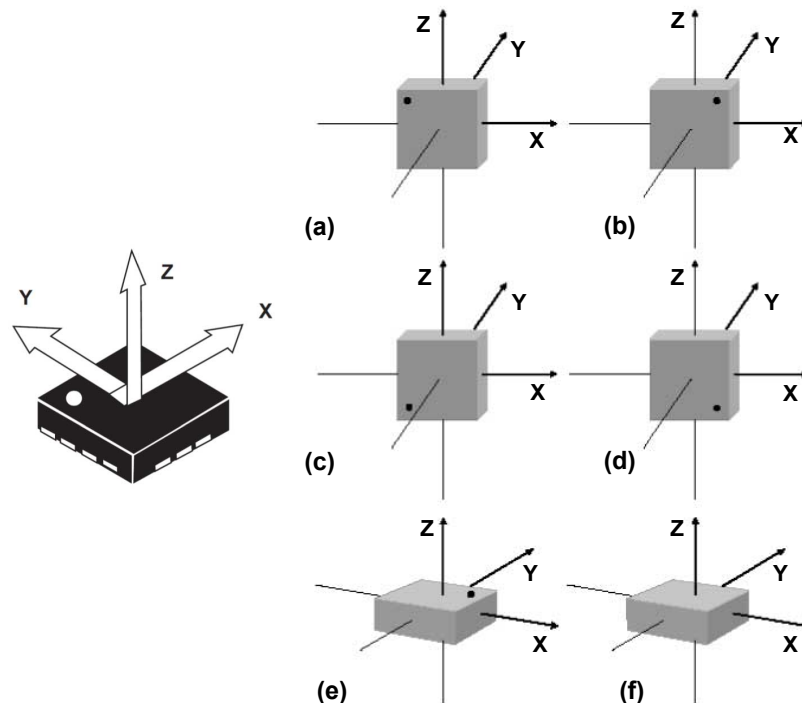
5.4.2 4D orientation detection

The 4D direction function is a subset of the 6D function especially defined to be implemented in mobile devices for portrait and landscape computation. It can be enabled by setting the D4D_EN bit of the THS_6D register to 1. In this configuration, the Z-axis position detection is disabled, therefore reducing position recognition to cases (a), (b), (c), and (d) of [Table 28. D6D_SRC register in 6D positions](#).

5.5 Activity/inactivity and motion/stationary recognition

The working principle of activity/inactivity and motion/stationary embedded functions is similar to wake-up. If no movement condition is detected for a programmable time, an inactivity/stationary condition event is generated. Otherwise, when the accelerometer data exceed the configurable threshold, an activity/motion condition event is generated.

The activity/inactivity recognition function allows reducing system power consumption and developing new smart applications.

When the activity/inactivity recognition function is activated, the device is able to automatically decrease the accelerometer sampling rate to 12.5 Hz (low-power mode) and to automatically increase the accelerometer ODR and bandwidth as soon as the wake-up interrupt event has been detected. This feature can be extended to the gyroscope, with three possible options:

- Gyroscope configurations do not change.
- Gyroscope enters in sleep mode.
- Gyroscope enters in power-down mode.

With this feature the system may be efficiently switched from low-power consumption to full performance and vice versa depending on user-selectable acceleration events, thus ensuring power saving and flexibility.

The activity/inactivity recognition function is enabled by setting the INTERRUPTS_ENABLE bit to 1 and configuring the INACT_EN[1:0] bits of the INT_CFG1 register. If the INACT_EN[1:0] bits of the INT_CFG1 register are equal to 00, the motion/stationary embedded function is enabled. Possible configurations of the inactivity event are summarized in the following table.

Table 29. Inactivity event configuration

INACT_EN[1:0]	Accelerometer	Gyroscope
00	Inactivity event disabled	Inactivity event disabled
01	XL ODR = 12.5 Hz (low-power mode)	Gyroscope configuration unchanged
10	XL ODR = 12.5 Hz (low-power mode)	Gyroscope in sleep mode
11	XL ODR = 12.5 Hz (low-power mode)	Gyroscope in power-down mode

The activity/inactivity and motion/stationary recognition functions can be implemented using either the slope filter (see [Section 3.5.1: Accelerometer slope filter](#) for more details) or the high-pass digital filter, as illustrated in [Figure 2. Accelerometer filtering chain](#). The filter to be applied can be selected using the SLOPE_FDS bit of the INT_CFG0 register. If this bit is set to 0 (default value), the slope filter is used. If it is set to 1, the high-pass digital filter is used.

This function can be fully programmed by the user in terms of expected amplitude and timing of the filtered data by means of a dedicated set of registers ([Figure 15. Activity/inactivity recognition \(using the slope filter\)](#)).

The unsigned threshold value is defined using the WK_THS[5:0] bits of the WAKE_UP_THS register. The value of 1 LSB of these 6 bits depends on the selected accelerometer full scale and on the value of the WAKE_THS_W bit of the WAKE_UP_DUR register:

- if WAKE_THS_W = 0, 1 LSB = $FS_{XL} / 2^6$.
- if WAKE_THS_W = 1, 1 LSB = $FS_{XL} / 2^8$.

The threshold is applied to both positive and negative filtered data.

When a certain number of consecutive X,Y,Z filtered data is smaller than the configured threshold, the ODR_XL[3:0] bits of the CTRL1_XL register are bypassed (Inactivity) and the accelerometer is internally set to 12.5 Hz although the content of CTRL1_XL is left untouched. The gyroscope behavior varies according to the configuration of the INACT_EN[1:0] bits of the INT_CFG1 register. The duration of the Inactivity status to be recognized is defined by the SLEEP_DUR[3:0] bits of the WAKE_UP_DUR register: 1 LSB corresponds to 512/ODR_XL time, where ODR_XL is the accelerometer output data rate. If the SLEEP_DUR[3:0] bits are set to 0000, the duration of the inactivity status to be recognized is equal to 16 / ODR_XL time.

When the inactivity status is detected, the interrupt is set high for 1/ODR_XL[s] period then it is automatically deasserted.

When filtered data on one axis becomes bigger than the threshold for a configurable time, the CTRL1_XL register settings are immediately restored (activity) and the gyroscope is restored to the previous state. The duration of the activity status to be recognized is defined by the WAKE_DUR[1:0] bits of the WAKE_UP_DUR register. 1 LSB corresponds to 1 / ODR_XL time, where ODR_XL is the accelerometer output data rate.

When the activity status is detected, the interrupt is set high for 1/ODR_XL[s] period then it is automatically deasserted.

Once the activity/inactivity detection function is enabled, the status can be driven to the two interrupt pins by setting to 1 the INT1_SLEEP_CHANGE bit of the MD1_CFG register or the INT2_SLEEP_CHANGE bit of the MD2_CFG register. It can also be checked by reading the SLEEP_CHANGE_IA bit of the WAKE_UP_SRC or ALL_INT_SRC register.

The SLEEP_CHANGE_IA bit is by default in pulsed mode. Latched mode can be selected by setting the LIR bit of the INT_CFG0 register to 1 and the INT1_SLEEP_CHANGE bit of the MD1_CFG register or the INT2_SLEEP_CHANGE bit of the MD2_CFG register to 1. The SLEEP_STATE bit of the WAKE_UP_SRC register is not affected by the LIR configuration. It corresponds to the current state of the device when the WAKE_UP_SRC register is read.

By setting the SLEEP_STATUS_ON_INT bit of the INT_CFG0 register to 1, the signal routed to the INT1 or INT2 pins is configured to be the activity/inactivity state (SLEEP_STATE bit of the WAKE_UP_SRC register) instead of the sleep-change signal. It goes high during inactivity state and it goes low during activity state. Latched mode is not supported in this configuration.

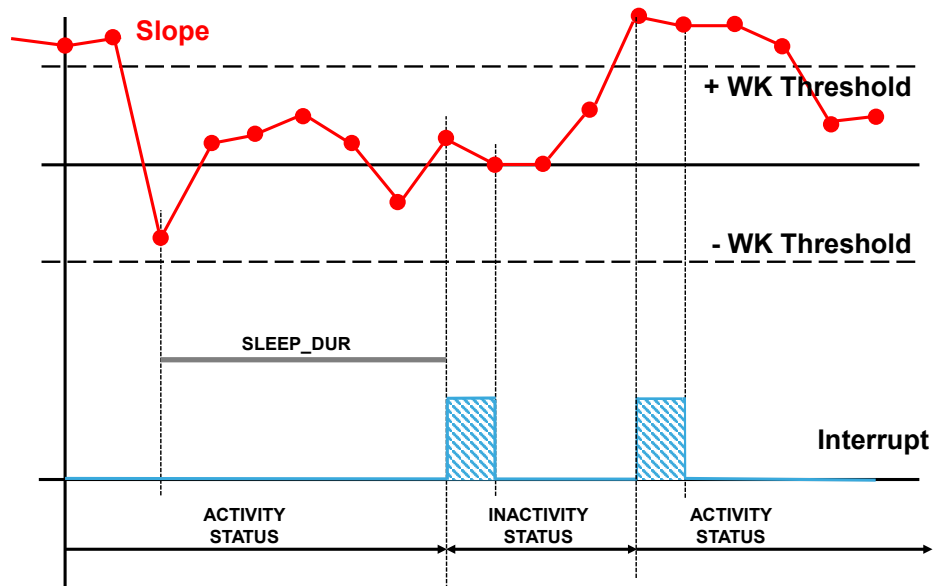
Figure 15. Activity/inactivity recognition (using the slope filter)

A basic software routine for activity/inactivity detection is as follows:

1. Write 50h to CTRL1_XL // Turn on the accelerometer
// ODR_XL = 208 Hz, FS_XL = ± 2 g
2. Write 40h to CTRL2_G // Turn on the gyroscope
// ODR_G = 104 Hz, FS_G = ± 250 dps
3. Write 02h to WAKE_UP_DUR // Set duration for inactivity detection
// Select activity/inactivity threshold resolution and duration
4. Write 02h to WAKE_UP_THS // Set activity/inactivity threshold
5. Write 00h to INT_CFG0 // Select sleep-change notification
// Select slope filter
6. Write E0h to INT_CFG1 // Enable interrupt
// Inactivity configuration: accelerometer to 12.5 Hz (LP mode),
// Gyroscope to power-down mode
7. Write 80h to MD1_CFG // Activity/inactivity interrupt driven to INT1 pin

In this example the WK_THS field of the WAKE_UP_THS register is set to 000010, therefore the Activity/Inactivity threshold is 62.5 mg ($= 2 * FS_{XL} / 2^6$ since the WAKE_THS_W bit of the WAKE_UP_DUR register is set to 0).

Before inactivity detection, the X,Y,Z slope data must be smaller than the configured threshold for a period of time defined by the SLEEP_DUR field of the WAKE_UP_DUR register. This field is set to 0010, corresponding to 4.92 s ($= 2 * 512 / ODR_{XL}$). After this period of time has elapsed, the accelerometer ODR is internally set to 12.5 Hz and the gyroscope is internally set to power-down mode.

The activity status is detected and the CTRL1_XL register settings are immediately restored and the gyroscope is turned on as soon as the slope data of (at least) one axis are bigger than the threshold for one sample, since the WAKE_DUR[1:0] bits of the WAKE_UP_DUR register are configured to 00.

5.5.1 Stationary/motion detection

Stationary/motion detection is a particular case of the activity/inactivity functionality in which no ODR / power mode changes occur when a sleep condition (equivalent to stationary condition) is detected. Stationary/motion detection is activated by setting the INACT_EN[1:0] bits of the INT_CFG1 register to 00.

5.6 Boot status

After the device is powered up, it performs a 10 ms (maximum) boot procedure to load the trimming parameters. After the boot is completed, both the accelerometer and the gyroscope are automatically configured in power-down mode. During the boot time, the registers are not accessible.

After power-up, the trimming parameters can be reloaded by setting the BOOT bit of the CTRL3_C register to 1.

In addition, at every boot / reboot cycle, the value of the embedded CRC (implemented as a warning against memory data corruption) is recalculated and compared with the stored one; the BOOT_CHECK_FAIL bit in STATUS_REG (1Eh) reports the result of this check (0: boot check passed; 1: boot check failed).

No toggle of the device power lines is required and the content of the device control registers is not modified, so the device operating mode does not change after boot. If the reset to the default value of the control registers is required, it can be performed by setting the SW_RESET bit of the CTRL3_C register to 1. When this bit is set to 1, the following registers are reset to their default value:

- FUNC_CFG_ACCESS (01h)
- PIN_CTRL (02h)
- FIFO_CTRL1 (07h) through FIFO_CTRL4 (0Ah)
- COUNTER_BDR_REG1 (0Bh) and COUNTER_BDR_REG2 (0Ch)
- INT1_CTRL (0Dh) and INT2_CTRL (0Eh)
- CTRL1_XL (10h) through CTRL10_C (19h)
- FIFO_STATUS1 (3Ah) and FIFO_STATUS2 (3Bh)
- INT_CFG0 (56h) through MD2_CFG (5Fh)
- I3C_BUS_AVB (62h)
- X_OFS_USR (73h), Y_OFS_USR (74h), and Z_OFS_USR (75h)

The SW_RESET procedure can take 50 μ s. The status of reset is signaled by the status of the SW_RESET bit of the CTRL3_C register. Once the reset is completed, this bit is automatically set low.

The boot status signal is driven to the INT1 interrupt pin by setting the INT1_BOOT bit of the INT1_CTRL register to 1. This signal is set high while the boot is running and it is set low again at the end of the boot procedure.

The reboot flow is as follows:

1. Set both the accelerometer and gyroscope in power-down mode
2. Set the INT1_BOOT bit of the INT1_CTRL register to 1 [optional]
3. Set the BOOT bit of the CTRL3_C register to 1
4. Monitor the reboot status, there are three possibilities:
 - a. Wait 10 ms
 - b. Monitor the INT1 pin until it returns to 0 (step 2. is mandatory in this case)
 - c. Poll the BOOT bit of CTRL3_C until it returns to 0

Reset flow is as follows:

1. Set both the accelerometer and gyroscope in power-down mode
2. Set the SW_RESET bit of CTRL3_C to 1
3. Monitor the software reset status, there are two possibilities:
 - a. Wait 50 μ s
 - b. Poll the SW_RESET bit of CTRL3_C until it returns to 0

In order to avoid conflicts, the reboot and the software reset must not be executed at the same time (do not set both the BOOT bit and the SW_RESET bit of the CTRL3_C register to 1 at the same time). The above flows must be performed serially.

6 Timestamp

Together with sensor data the device can provide timestamp information.

To enable this functionality the `TIMESTAMP_EN` bit of the `CTRL10_C` register has to be set to 1. The time step count is given by the concatenation of the `TIMESTAMP3` & `TIMESTAMP2` & `TIMESTAMP1` & `TIMESTAMP0` registers and is represented as a 32-bit unsigned number.

The nominal timestamp resolution is 25 μ s. It is possible to get the actual timestamp resolution value through the `FREQ_FINE[7:0]` bits of the `INTERNAL_FREQ_FINE` register, which contains the difference in percentage of the actual ODR (and timestamp rate) with respect to the nominal value.

$$t_{actual}[s] = \frac{1}{40000 \cdot (1 + 0.0015 \cdot FREQ_FINE)}$$

Similarly, it is possible to get the actual output data rate by using the following formula:

$$ODR_{actual}[Hz] = \frac{6667 + 0.0015 \cdot FREQ_FINE \cdot 6667}{ODR_{coeff}}$$

where the `ODRcoeff` values are indicated in the table below.

Table 30. ODR_{coeff} values

Selected ODR [Hz]	ODR _{coeff}
12.5	512
26	256
52	128
104	64
208	32
416	16
833	8
1667	4

If both the accelerometer and the gyroscope are in power-down mode, the timestamp counter does not work and the timestamp value is frozen at the last value.

When the maximum value 4294967295 LSB (equal to FFFFFFFFh) is reached corresponding to approximately 30 hours, the counter is automatically reset to 00000000h and continues to count. The timer count can be reset to zero at any time by writing the reset value AAh in the `TIMESTAMP2` register.

The `TIMESTAMP_ENDCOUNT` bit of the `ALL_INT_SRC` goes high 6.4 ms before the occurrence of a timestamp overrun condition. This flag is reset when the `ALL_INT_SRC` register is read. It is also possible to route this signal to the INT2 pin (75 μ s duration pulse) by setting the `INT2_TIMESTAMP` bit of `MD2_CFG` to 1.

The timestamp can be batched in FIFO (see [Section 7: First-in, first-out \(FIFO\) buffer](#) for details).

7 First-in, first-out (FIFO) buffer

In order to limit intervention by the host processor and facilitate post-processing data for event recognition, the ASM330LHBG1 embeds a 3 KB first-in, first-out buffer (FIFO).

The FIFO can be configured to store the following data:

- Gyroscope sensor data
- Accelerometer sensor data
- Timestamp data
- Temperature sensor data

Saving the data in FIFO is based on FIFO words. A FIFO word is composed of:

- Tag, 1 byte
- Data, 6 bytes

Data can be retrieved from the FIFO through six dedicated registers, from address 79h to 7Eh: FIFO_DATA_OUT_X_L, FIFO_DATA_OUT_X_H, FIFO_DATA_OUT_Y_L, FIFO_DATA_OUT_Y_H, FIFO_DATA_OUT_Z_L, FIFO_DATA_OUT_Z_H.

The reconstruction of a FIFO stream is a simple task thanks to the FIFO_TAG field of the FIFO_DATA_OUT_TAG register that allows recognizing the meaning of a word in FIFO. The applications have maximum flexibility in choosing the rate of batching for sensors with dedicated FIFO configurations.

Six different FIFO operating modes can be chosen through the FIFO_MODE[2:0] bits of the FIFO_CTRL4 register:

- Bypass mode
- FIFO mode
- Continuous mode
- Continuous-to-FIFO mode
- Bypass-to-continuous mode
- Bypass-to-FIFO mode

To monitor the FIFO status (full, overrun, number of samples stored, and so forth), two dedicated registers are available: FIFO_STATUS1 and FIFO_STATUS2.

Programmable FIFO threshold can be set in FIFO_CTRL1 and FIFO_CTRL2 using the WTM[8:0] bits.

FIFO full, FIFO threshold, and FIFO overrun events can be enabled to generate dedicated interrupts on the two interrupt pins (INT1 and INT2) through the INT1_FIFO_FULL, INT1_FIFO_FTH and INT1_FIFO_OVR bits of the INT1_CTRL register, and through the INT2_FIFO_FULL, INT2_FIFO_FTH and INT2_FIFO_OVR bits of the INT2_CTRL register.

7.1 FIFO description and batched sensors

FIFO is divided into 512 words of 7 bytes each. A FIFO word contains one byte with TAG information and 6 bytes of data. The overall FIFO buffer dimension is equal to 3584 bytes and can contain 3072 bytes of data. The TAG byte contains the information indicating which data is stored in the FIFO data field and other useful information.

FIFO is runtime configurable. A meta-information tag can be enabled in order to notify the user if batched sensor configurations have changed.

Batched sensors can be classified in two different categories:

1. Main sensors, which are physical sensors:
 - a. Accelerometer sensor
 - b. Gyroscope sensor
2. Auxiliary sensors, which contain information of the status of the device:
 - a. Timestamp sensor
 - b. Configuration-change sensor (CFG-change)
 - c. Temperature sensor

Data can be retrieved from the FIFO through six dedicated registers: FIFO_DATA_OUT_X_L, FIFO_DATA_OUT_X_H, FIFO_DATA_OUT_Y_L, FIFO_DATA_OUT_Y_H, FIFO_DATA_OUT_Z_L, FIFO_DATA_OUT_Z_H.

A write to FIFO is triggered by the internal data-ready signal (fastest sensor between the accelerometer and gyroscope).

7.2 FIFO registers

The FIFO buffer is managed by:

- Six control registers: FIFO_CTRL1, FIFO_CTRL2, FIFO_CTRL3, FIFO_CTRL4, COUNTER_BDR_REG1, COUNTER_BDR_REG2
- Two status registers: FIFO_STATUS1 and FIFO_STATUS2
- Seven output registers (tag + data): FIFO_DATA_OUT_TAG, FIFO_DATA_OUT_X_L, FIFO_DATA_OUT_X_H, FIFO_DATA_OUT_Y_L, FIFO_DATA_OUT_Y_H, FIFO_DATA_OUT_Z_L, FIFO_DATA_OUT_Z_H
- Some additional bits to route FIFO events to the two interrupt lines: INT1_CNT_BDR, INT1_FIFO_FULL, INT1_FIFO_OVR, INT1_FIFO_TH bits of the INT1_CTRL register and INT2_CNT_BDR, INT2_FIFO_FULL, INT2_FIFO_OVR, INT2_FIFO_TH bits of the INT2_CTRL register

7.2.1 FIFO_CTRL1

The FIFO_CTRL1 register contains the lower part of the 9-bit FIFO watermark threshold level. For the complete watermark threshold level configuration, consider also the WTM8 bit of the FIFO_CTRL2 register. 1 LSB value of the FIFO threshold level is referred to as a FIFO word (7 bytes).

The FIFO watermark flag (FIFO_WTM_IA bit in the FIFO_STATUS2 register) rises when the number of bytes stored in the FIFO is equal to or higher than the watermark threshold level.

In order to limit the FIFO depth to the watermark level, the STOP_ON_WTM bit must be set to 1 in the FIFO_CTRL2 register.

Table 31. FIFO_CTRL1 register

Bit 7	Bit 6	Bit 5	Bit 4	Bit 3	Bit 2	Bit 1	Bit 0
WTM7	WTM6	WTM5	WTM4	WTM3	WTM2	WTM1	WTM0

7.2.2 FIFO_CTRL2

Table 32. FIFO_CTRL2 register

Bit 7	Bit 6	Bit 5	Bit 4	Bit 3	Bit 2	Bit 1	Bit 0
STOP_ON_WTM	0	0	ODRCHG_EN	0	0	0	WTM8

The FIFO_CTRL2 register contains the upper part of the 9-bit FIFO watermark threshold level (WTM8 bit). For the complete watermark threshold level configuration, consider also the WTM[7:0] bits of the FIFO_CTRL1 register. The register contains the bit STOP_ON_WTM which allows limiting the FIFO depth to the watermark level.

Moreover, the FIFO_CTRL2 register contains the ODRCHG_EN bit which can be set to 1 in order to enable the CFG-change auxiliary sensor to be batched in FIFO (described in the next sections).

7.2.3 FIFO_CTRL3

Table 33. FIFO_CTRL3 register

Bit 7	Bit 6	Bit 5	Bit 4	Bit 3	Bit 2	Bit 1	Bit 0
BDR_GY_3	BDR_GY_2	BDR_GY_1	BDR_GY_0	BDR_XL_3	BDR_XL_2	BDR_XL_1	BDR_XL_0

The FIFO_CTRL3 register contains the fields to select the write frequency in FIFO for accelerometer and gyroscope sensor data. The selected batch data rate must be equal to or lower than the output data rate configured through the ODR_XL and ODR_G fields of the CTRL1_XL and CTRL2_G registers.

The following tables indicate all the selectable batch data rates.

Table 34. Accelerometer batch data rate

BDR_XL[3:0]	Batch data rate [Hz]
0000	Not batched in FIFO
0001	12.5
0010	26
0011	52
0100	104
0101	208
0110	416
0111	833
1000	1667
1011	1.6

Table 35. Gyroscope batch data rate

BDR_GY[3:0]	Batch data rate [Hz]
0000	Not batched in FIFO
0001	12.5
0010	26
0011	52
0100	104
0101	208
0110	416
0111	833
1000	1667
1011	6.5

7.2.4 FIFO_CTRL4

The FIFO_CTRL4 register contains the fields to select the decimation factor for timestamp batching in FIFO and the batch data rate for the temperature sensor.

The timestamp write rate is configured to the maximum rate between the accelerometer and gyroscope batch data rate divided by the decimation factor specified in the DEC_TS_BATCH_[1:0] field. The programmable decimation factors are indicated in the table below.

Table 36. Timestamp batch data rate

DEC_TS_BATCH[1:0]	Timestamp batch data rate [Hz]
00	Not batched in FIFO
01	$\max(\text{BDR_GY}[\text{Hz}], \text{BDR_XL}[\text{Hz}])$
10	$\max(\text{BDR_GY}[\text{Hz}], \text{BDR_XL}[\text{Hz}]) / 8$
11	$\max(\text{BDR_GY}[\text{Hz}], \text{BDR_XL}[\text{Hz}]) / 32$

The temperature batch data rate is configurable through the ODR_T_BATCH_[1:0] field as shown in the table below.

Table 37. Temperature sensor batch data rate

ODR_T_BATCH[1:0]	Temperature batch data rate [Hz]
00	Not batched in FIFO
01	1.6
10	12.5
11	52

The FIFO_CTRL4 register also contains the FIFO operating modes bits. FIFO operating modes are described in [Section 7.6: FIFO modes](#).

Table 38. FIFO_CTRL4 register

Bit 7	Bit 6	Bit 5	Bit 4	Bit 3	Bit 2	Bit 1	Bit 0
DEC_TS_BATCH_1	DEC_TS_BATCH_0	ODR_T_BATCH_1	ODR_T_BATCH_0	0	FIFO_MODE2	FIFO_MODE1	FIFO_MODE0

7.2.5 COUNTER_BDR_REG1

Since the FIFO might contain meta-information (that is, CFG-change sensor), the FIFO provides a way to synchronize the FIFO reading on the basis of the accelerometer or gyroscope actual number of samples stored in FIFO: the BDR counter.

The BDR counter can be configured through the COUNTER_BDR_REG1 and COUNTER_BDR_REG2 registers.

Table 39. COUNTER_BDR_REG1 register

Bit 7	Bit 6	Bit 5	Bit 4	Bit 3	Bit 2	Bit 1	Bit 0
-	RST_COUNTER_BDR	TRIG_COUNTER_BDR	0	0	CNT_BDR_TH_10	CNT_BDR_TH_9	CNT_BDR_TH_8

RST_COUNTER_BDR can be asserted to reset the BDR counter. It is automatically reset to zero.

TRIG_COUNTER_BDR selects the trigger for the BDR counter. If it is configured to 0, accelerometer sensor is selected, otherwise gyroscope sensor is selected.

The user can select the threshold which generates the COUNTER_BDR_IA event in the FIFO_STATUS2 register. Once the internal BDR counter reaches the threshold, the COUNTER_BDR_IA bit is set to 1. The threshold is configurable through the CNT_BDR_TH_[10:0] bits. The upper part of the field is contained in register COUNTER_BDR_REG1. 1 LSB value of the CNT_BDR_TH threshold level is referred to as one accelerometer/gyroscope sample (X, Y and Z data).

7.2.6 COUNTER_BDR_REG2

The COUNTER_BDR_REG2 register contains the lower part of the BDR-counter threshold.

Table 40. COUNTER_BDR_REG2 register

Bit 7	Bit 6	Bit 5	Bit 4	Bit 3	Bit 2	Bit 1	Bit 0
CNT_BDR_TH_7	CNT_BDR_TH_6	CNT_BDR_TH_5	CNT_BDR_TH_4	CNT_BDR_TH_3	CNT_BDR_TH_2	CNT_BDR_TH_1	CNT_BDR_TH_0

7.2.7 FIFO_STATUS1

The FIFO_STATUS1 register, together with the FIFO_STATUS2 register, provides information about the number of samples stored in the FIFO. 1 LSB value of the DIFF_FIFO level is referred to as a FIFO word (7 bytes).

Table 41. FIFO_STATUS1 register

Bit 7	Bit 6	Bit 5	Bit 4	Bit 3	Bit 2	Bit 1	Bit 0
DIFF_FIFO_7	DIFF_FIFO_6	DIFF_FIFO_5	DIFF_FIFO_4	DIFF_FIFO_3	DIFF_FIFO_2	DIFF_FIFO_1	DIFF_FIFO_0

7.2.8 FIFO_STATUS2

The FIFO_STATUS2 register, together with the FIFO_STATUS1 register, provides information about the number of samples stored in the FIFO and about the current status (watermark, overrun, full, BDR counter) of the FIFO buffer.

Table 42. FIFO_STATUS2 register

Bit 7	Bit 6	Bit 5	Bit 4	Bit 3	Bit 2	Bit 1	Bit 0
FIFO_WTM_IA	FIFO_OVR_IA	FIFO_FULL_IA	COUNTER_BDR_IA	FIFO_OVR_LATCHED	0	DIFF_FIFO_9	DIFF_FIFO_8

- FIFO_WTM_IA represents the watermark status. This bit goes high when the number of FIFO words (7 bytes each) already stored in the FIFO is equal to or higher than the watermark threshold level. The watermark status signal can be driven to the two interrupt pins by setting to 1 the INT1_FIFO_TH bit of the INT1_CTRL register or the INT2_FIFO_TH bit of the INT2_CTRL register.
- FIFO_OVR_IA goes high when the FIFO is completely filled and at least one sample has already been overwritten to store the new data. This signal can be driven to the two interrupt pins by setting to 1 the INT1_FIFO_OVR bit of the INT1_CTRL register or the INT2_FIFO_OVR bit of the INT2_CTRL register.
- FIFO_FULL_IA goes high when the next set of data that is stored in FIFO makes the FIFO completely full (that is, DIFF_FIFO_9 = 1) or generates a FIFO overrun. This signal can be driven to the two interrupt pins by setting to 1 the INT1_FIFO_FULL bit of the INT1_CTRL register or the INT2_FIFO_FULL bit of the INT2_CTRL register.
- COUNTER_BDR_IA represents the BDR-counter status. This bit goes high when the number of accelerometer or gyroscope batched samples (on the base of the selected sensor trigger) reaches the BDR-counter threshold level configured through the CNT_BDR_TH_[10:0] bits of the COUNTER_BDR_REG1 and COUNTER_BDR_REG2 registers. The COUNTER_BDR_IA bit is automatically reset when the FIFO_STATUS2 register is read. The BDR-counter status can be driven to the two interrupt pins by setting to 1 the INT1_CNT_BDR bit of the INT1_CTRL register or the INT2_CNT_BDR bit of the INT2_CTRL register.
- FIFO_OVR_LATCHED, as FIFO_OVR_IA, goes high when the FIFO is completely filled and at least one sample has already been overwritten to store the new data. The difference between the two flags is that FIFO_OVR_LATCHED is reset when the FIFO_STATUS2 register is read, whereas the FIFO_OVR_IA is reset when at least one FIFO word is read. This allows detecting a FIFO overrun condition during reading data from FIFO.
- DIFF_FIFO_[9:8] contains the upper part of the number of unread words stored in the FIFO. The lower part is represented by the DIFF_FIFO_[7:0] bits in FIFO_STATUS1. The value of the DIFF_FIFO_[9:0] field corresponds to the number of 7-byte words in the FIFO.

Register content is updated synchronously to the FIFO write and read operations.

Note: The BDU feature also acts on the FIFO_STATUS1 and FIFO_STATUS2 registers. When the BDU bit is set to 1, it is mandatory to read FIFO_STATUS1 first and then FIFO_STATUS2.

7.2.9 FIFO_DATA_OUT_TAG

By reading the FIFO_DATA_OUT_TAG register, it is possible to understand to which sensor the data of the current reading belongs and to check if data are consistent.

Table 43. FIFO_DATA_OUT_TAG register

Bit 7	Bit 6	Bit 5	Bit 4	Bit 3	Bit 2	Bit 1	Bit 0
TAG_SENSOR_4	TAG_SENSOR_3	TAG_SENSOR_2	TAG_SENSOR_1	TAG_SENSOR_0	TAG_CNT_1	TAG_CNT_0	TAG_PARITY

- TAG_SENSOR_[4:0] field identifies the sensors stored in the 6 data bytes (Table 44).
- TAG_CNT_[1:0] field identifies the FIFO time slot (described in next sections).
- TAG_PARITY bit recognizes if the content of the FIFO_DATA_OUT_TAG register is corrupted.

The table below contains all the possible values and associated type of sensor for the TAG_SENSOR_[4:0] field.

Table 44. TAG_SENSOR field and associated sensor

TAG_SENSOR_[4:0]	Sensor name	Sensor category	Description
0x01	Gyroscope	Main	Gyroscope data
0x02	Accelerometer	Main	Accelerometer data
0x03	Temperature	Auxiliary	Temperature data
0x04	Timestamp	Auxiliary	Timestamp data
0x05	CFG_Change	Auxiliary	Meta-information data

The TAG_PARITY bit can be used to check the content of the FIFO_DATA_OUT_TAG register. In order to do this, the user can implement the following routine:

1. Read the FIFO_DATA_OUT_TAG register.
2. Count the number of bits equal to 1,
3. If the number of bits equal to 1 is even, then the FIFO_DATA_OUT_TAG content is reliable, otherwise it is unreliable.

7.2.10 FIFO_DATA_OUT

Data can be retrieved from the FIFO through six dedicated registers, from address 79h to address 7Eh: FIFO_DATA_OUT_X_L, FIFO_DATA_OUT_X_H, FIFO_DATA_OUT_Y_L, FIFO_DATA_OUT_Y_H, FIFO_DATA_OUT_Z_L, FIFO_DATA_OUT_Z_H.

The FIFO output registers content depends on the sensor category and type, as described in the next section.

7.3 FIFO batched sensors

As previously described, batched sensors can be classified in two different categories:

1. Main sensors
2. Auxiliary sensors

In the following sections, details about each category are presented.

7.4 Main sensors

The main sensors are the ASM330LHBG1 device physical sensors: accelerometer and gyroscope. The batch data rate can be configured through the BDR_XL[3:0] and BDR_GY[3:0] fields of the FIFO_CTRL3 register. The batch data rate must be equal to or lower than the relative sensor output data rate configured through the ODR_XL[3:0] and ODR_G[3:0] field of the CTRL1_XL and CTRL2_G registers.

The main sensors define the FIFO time base. This means that each one of the other sensors can be associated to a time base slot defined by the main sensors. A batch event of the fastest main sensor also increments the TAG counter (TAG_CNT field of the FIFO_DATA_OUT_TAG register). This counter is composed of two bits and its value is continuously incremented (from 00 to 11) to identify different time slots.

An example of a batch data rate event is shown in Figure 16. Main sensors and time slot definitions. The BDR_GY event and BDR_XL event identify the time in which the corresponding sensor data is written to the FIFO. The evolution of the TAG counter identifies different time slots and its frequency is equivalent to the maximum value between BDR_XL and BDR_GY.

Figure 16. Main sensors and time slot definitions

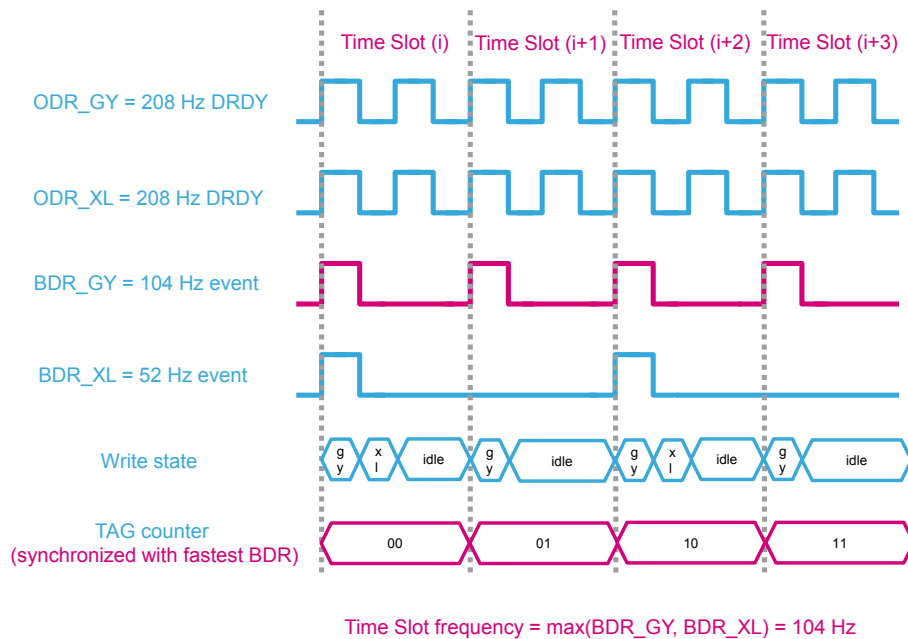

The FIFO word format of the main sensors is presented in the table below, representing the device addresses from 78h to 7Eh.

Table 45. Main sensors output data format in FIFO

TAG	X_L	X_H	Y_L	Y_H	Z_L	Z_H
-----	-----	-----	-----	-----	-----	-----

7.5 Auxiliary sensors

Auxiliary sensors are considered as service sensors for the main sensors. Auxiliary sensors include the:

- Temperature sensor (ODR_T_BATCH_[1:0] bits of the FIFO_CTRL4 register must be configured properly).
- Timestamp sensor: it stores the timestamp corresponding to a FIFO time slot (the TIMESTAMP_EN bit of the CTRL10_C register must be set to 1 and the DEC_TS_BATCH_[1:0] bits of the FIFO_CTRL4 register must be configured properly).
- CFG-change sensor: it identifies a change in some configuration of the device (ODRCHG_EN bit of the FIFO_CTRL2 register must be set to 1).

Auxiliary sensors cannot trigger a write in FIFO. Their registers are written when the first main sensor event occurs (even if they are configured at a higher batch data rate).

The temperature output data format in FIFO is presented in the following table.

Table 46. Temperature output data format in FIFO

Data	FIFO_DATA_OUT registers
TEMPERATURE[7:0]	FIFO_DATA_OUT_X_L
TEMPERATURE[15:8]	FIFO_DATA_OUT_X_H
0	FIFO_DATA_OUT_Y_L
0	FIFO_DATA_OUT_Y_H
0	FIFO_DATA_OUT_Z_L
0	FIFO_DATA_OUT_Z_H

The timestamp output data format in FIFO is presented in the following table.

Table 47. Timestamp output data format in FIFO

Data	FIFO_DATA_OUT registers
TIMESTAMP[7:0]	FIFO_DATA_OUT_X_L
TIMESTAMP[15:8]	FIFO_DATA_OUT_X_H
TIMESTAMP[23:16]	FIFO_DATA_OUT_Y_L
TIMESTAMP[31:24]	FIFO_DATA_OUT_Y_H
0	FIFO_DATA_OUT_Z_L
BDR_XL	FIFO_DATA_OUT_Z_H[3:0]
BDR_GY	FIFO_DATA_OUT_Z_H[7:4]

As shown in [Table 47](#), the timestamp data contain also some meta-information, which can be used to detect a BDR change if the CFG-change sensor is not batched in FIFO: the batch data rate of the main sensors.

CFG-change identifies a runtime change in the output data rate, the batch data rate, or other configurations of the main sensors. When a supported runtime change is applied, this sensor is written at the first new main sensor event followed by a timestamp sensor (also if the timestamp sensor is not batched).

This sensor can be used to correlate data from the sensors to the device timestamp without storing the timestamp each time. It could be used also to notify the user to discard data due to embedded filters settling or to other configuration changes (that is, switching mode, output data rate, and so forth).

CFG-change output data format in FIFO is presented in the following table.

Table 48. CFG-change output data format in FIFO

Data	FIFO_DATA_OUT registers
LPF1_SEL_G	FIFO_DATA_OUT_X_H[0]
FTYPE[2:0]	FIFO_DATA_OUT_X_H[3:1]
G_HM_MODE	FIFO_DATA_OUT_X_H[4]
FS_125	FIFO_DATA_OUT_X_H[5]
FS[1:0]_G	FIFO_DATA_OUT_X_H[7:6]
LPF2_XL_EN	FIFO_DATA_OUT_Y_L[0]
HPCF_XL[2:0]	FIFO_DATA_OUT_Y_L[3:1]
XL_HM_MODE	FIFO_DATA_OUT_Y_L[4]
0	FIFO_DATA_OUT_Y_L[5]
FS[1:0]_XL	FIFO_DATA_OUT_Y_L[7:6]
0	FIFO_DATA_OUT_Y_H[5:0]
Gyroscope startup ⁽¹⁾	FIFO_DATA_OUT_Y_H[6]
0	FIFO_DATA_OUT_Y_H[7]
ODR_XL	FIFO_DATA_OUT_Z_L[3:0]
ODR_GY	FIFO_DATA_OUT_Z_L[7:4]
BDR_XL	FIFO_DATA_OUT_Z_H[3:0]
BDR_GY	FIFO_DATA_OUT_Z_H[7:4]

1. Internal signal that is deasserted when the gyroscope finishes the startup phase (max startup time is 70 ms).

7.6 FIFO modes

The ASM330LHBG1 FIFO buffer can be configured to operate in six different modes, selectable through the FIFO_MODE_[2:0] field of the FIFO_CTRL4 register. The available configurations ensure a high level of flexibility and extend the number of functions usable in application development.

Bypass, FIFO, continuous, continuous-to-FIFO, bypass-to-continuous, and bypass-to-FIFO modes are described in the following paragraphs.

7.6.1 Bypass mode

When bypass mode is enabled, the FIFO is not used, the buffer content is cleared, and it remains empty until another mode is selected. Bypass mode is selected when the FIFO_MODE_[2:0] bits are set to 000. Bypass mode must be used in order to stop and reset the FIFO buffer when a different mode is intended to be used. Note that by placing the FIFO buffer into bypass mode, the whole buffer content is cleared.

7.6.2 FIFO mode

In FIFO mode, the buffer continues filling until it becomes full. Then it stops collecting data and the FIFO content remains unchanged until a different mode is selected.

Follow these steps for FIFO mode configuration:

1. Enable the sensor data to be stored in FIFO with the corresponding batch data rate (if configurable).
2. Set the FIFO_MODE_[2:0] bits in the FIFO_CTRL4 register to 001 to enable FIFO mode.

When this mode is selected, the FIFO starts collecting data. The FIFO_STATUS1 and FIFO_STATUS2 registers are updated according to the number of samples stored.

When the FIFO is full, the DIFF_FIFO_9 bit of the FIFO_STATUS2 register is set to 1 and no more data are stored in the FIFO buffer. Data can be retrieved by reading all the FIFO_DATA_OUT (from 78h to 7Eh) registers for the number of times specified by the DIFF_FIFO_[9:0] bits of the FIFO_STATUS1 and FIFO_STATUS2 registers.

Using the FIFO_WTM_IA bit of the FIFO_STATUS2 register, data can also be retrieved when a threshold level (WTM[8:0] in FIFO_CTRL1 and FIFO_CTRL2 registers) is reached if the application requires a lower number of samples in the FIFO.

If the STOP_ON_WTM bit of the FIFO_CTRL2 register is set to 1, the FIFO size is limited to the value of the WTM[8:0] bits in the FIFO_CTRL1 and FIFO_CTRL2 registers. In this case, the FIFO_FULL_IA bit of the FIFO_STATUS2 register is set high when the number of samples in FIFO reaches or exceeds the WTM[8:0] value at the next FIFO write operation.

Communication speed is not very important in FIFO mode because the data collection is stopped and there is no risk of overwriting data already acquired. Before restarting the FIFO mode, it is necessary to set to bypass mode first in order to completely clear the FIFO content.

Figure 17. FIFO mode (STOP_ON_WTM = 0) shows an example of FIFO mode usage. The data from just one sensor are stored in the FIFO. In these conditions, the number of samples that can be stored in the FIFO buffer is 512. The FIFO_FULL_IA bit of the FIFO_STATUS2 register goes high just after the level labeled as 510 to notify that the FIFO buffer will be completely filled at the next FIFO write operation. After the FIFO is full (FIFO_DIFF_9 = 1), the data collection stops.

Figure 17. FIFO mode (STOP_ON_WTM = 0)

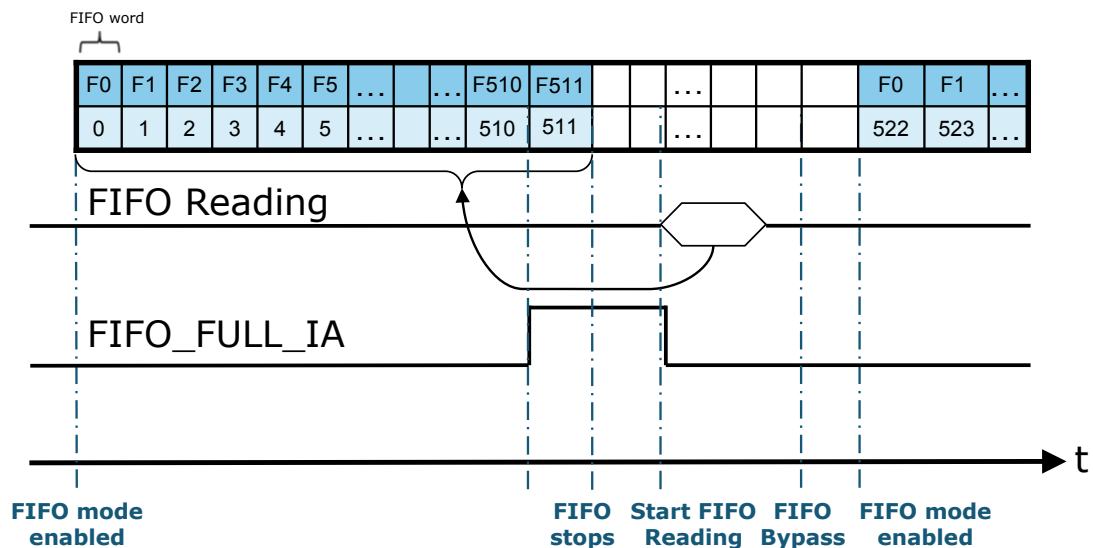

7.6.4 Continuous-to-FIFO mode

This mode is a combination of the continuous and FIFO modes previously described. In continuous-to-FIFO mode, the FIFO buffer starts operating in continuous mode and switches to FIFO mode when an event condition occurs.

The event condition can be one of the following:

- Free-fall: event detection has to be configured and the INT2_FF bit of the MD2_CFG register has to be set to 1.
- Wake-up: event detection has to be configured and the INT2_WU bit of the MD2_CFG register has to be set to 1.
- 6D: event detection has to be configured and the INT2_6D bit of the MD2_CFG register has to be set to 1.

Continuous-to-FIFO mode is sensitive to the edge of the interrupt signal. At the first interrupt event, FIFO changes from continuous mode to FIFO mode and maintains it until bypass mode is set.

Figure 19. Continuous-to-FIFO mode

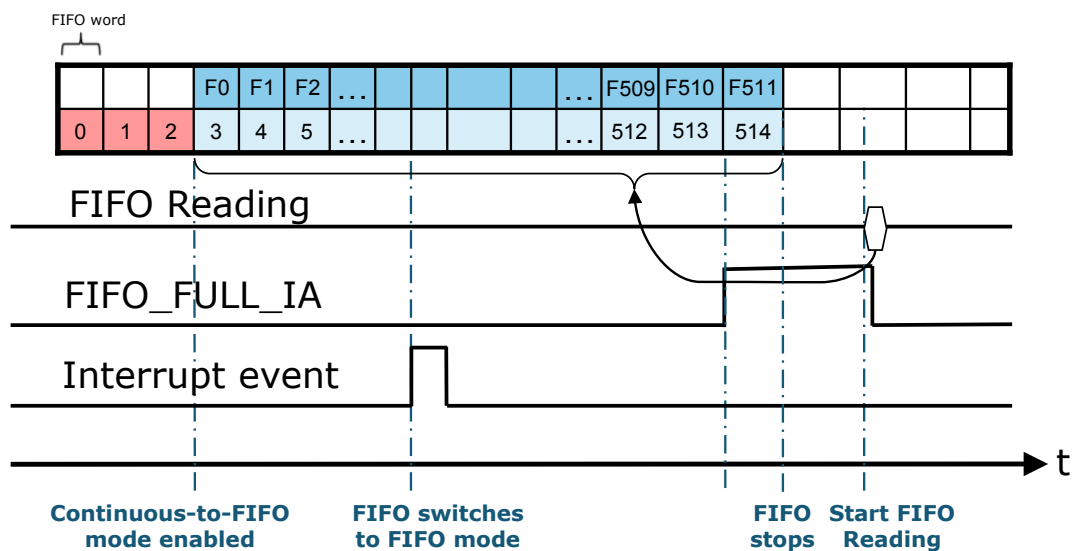

Follow these steps for continuous-to-FIFO mode configuration (if the accelerometer/gyroscope data-ready is used as the FIFO trigger):

1. Configure one of the events as previously described.
2. Enable the sensor data to be stored in FIFO with the corresponding batch data rate (if configurable).
3. Set the FIFO_MODE_[2:0] bits in the FIFO_CTRL4 register to 011 to enable FIFO continuous-to-FIFO mode.

In continuous-to-FIFO mode the FIFO buffer continues filling. When the FIFO is full or overruns at the next FIFO write operation, the FIFO_FULL_IA bit goes high.

If the STOP_ON_WTM bit of the FIFO_CTRL2 register is set to 1, the FIFO size is limited to the value of the WTM[8:0] bits in the FIFO_CTRL1 and FIFO_CTRL2 registers. In this case, the FIFO_FULL_IA bit of the FIFO_STATUS2 register goes high when the number of samples in FIFO reaches or exceeds the WTM[8:0] value on the next FIFO write operation.

When the trigger event occurs, two different cases can be observed:

1. If the FIFO buffer is already full, it stops collecting data at the first sample after the event trigger. The FIFO content is composed of the samples collected before the event.
2. If FIFO buffer is not full yet, it continues filling until it becomes full and then it stops collecting data.

Continuous-to-FIFO can be used in order to analyze the history of the samples which have generated an interrupt. The standard operation is to read the FIFO content when the FIFO mode is triggered and the FIFO buffer is full and stopped.

7.6.5 Bypass-to-continuous mode

This mode is a combination of the bypass and continuous modes previously described. In bypass-to-continuous mode, the FIFO buffer starts operating in bypass mode and switches to continuous mode when an event condition occurs.

The event condition can be one of the following:

- Free-fall: event detection has to be configured and the INT2_FF bit of the MD2_CFG register has to be set to 1.
- Wake-up: event detection has to be configured and the INT2_WU bit of the MD2_CFG register has to be set to 1.
- 6D: event detection has to be configured and the INT2_6D bit of the MD2_CFG register has to be set to 1.

Bypass-to-continuous mode is sensitive to the edge of the interrupt signal: at the first interrupt event, FIFO changes from bypass mode to continuous mode and maintains it until bypass mode is set.

Follow these steps for bypass-to-continuous mode configuration (if the accelerometer / gyroscope data-ready is used as the FIFO trigger):

1. Configure one of the events as previously described.
2. Enable the sensor data to be stored in FIFO with the corresponding batch data rate (if configurable).
3. Set the FIFO_MODE[2:0] bits in the FIFO_CTRL4 register to 100 to enable FIFO bypass-to-continuous mode.

Once the trigger condition appears and the buffer switches to continuous mode, the FIFO buffer continues filling. When the next stored set of data makes the FIFO full or overrun, the FIFO_FULL_IA bit is set high.

Bypass-to-continuous can be used in order to start the acquisition when the configured interrupt is generated.

Figure 20. Bypass-to-continuous mode

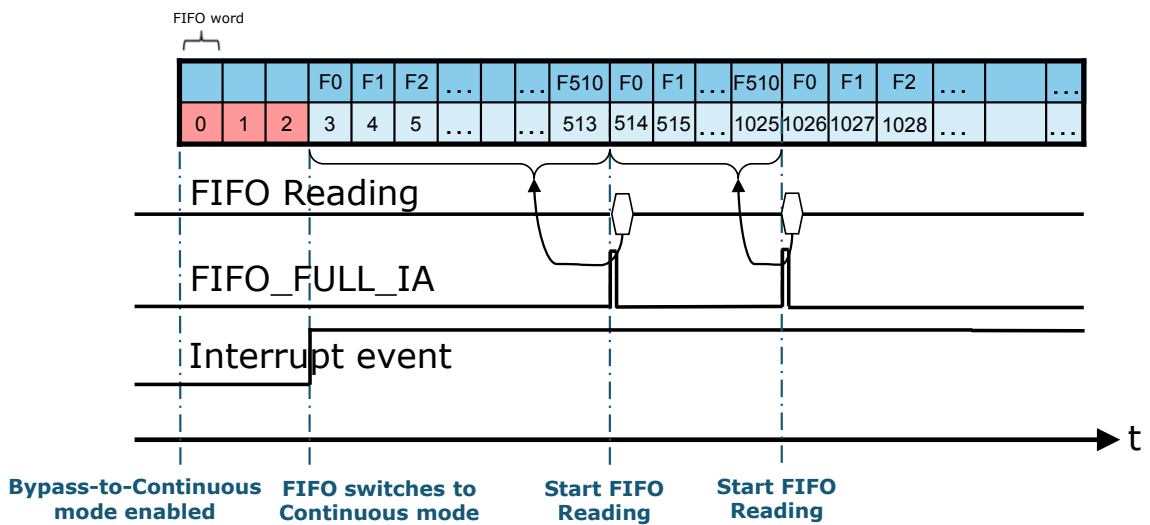

7.6.6 Bypass-to-FIFO mode

This mode is a combination of the bypass and FIFO modes previously described. In bypass-to-FIFO mode, the FIFO buffer starts operating in bypass mode and switches to FIFO mode when an event condition occurs.

The event condition can be one of the following:

- Free-fall: event detection has to be configured and the INT2_FF bit of the MD2_CFG register has to be set to 1.
- Wake-up: event detection has to be configured and the INT2_WU bit of the MD2_CFG register has to be set to 1.
- 6D: event detection has to be configured and the INT2_6D bit of the MD2_CFG register has to be set to 1.

Bypass-to-FIFO mode is sensitive to the edge of the interrupt signal. At the first interrupt event, FIFO changes from bypass mode to FIFO mode and maintains it until bypass mode is set.

Follow these steps for bypass-to-FIFO mode configuration (if the accelerometer / gyroscope data-ready is used as the FIFO trigger):

1. Configure one of the events as previously described.
2. Enable the sensor data to be stored in FIFO with the corresponding batch data rate (if configurable).
3. Set the FIFO_MODE_[2:0] bits in the FIFO_CTRL4 register to 111 to enable FIFO bypass-to-FIFO mode.

Once the trigger condition appears and the buffer switches to FIFO mode, the FIFO buffer starts filling. When the next stored set of data makes the FIFO full or overrun, the FIFO_FULL_IA bit is set high and the FIFO stops.

Bypass-to-FIFO can be used in order to analyze the history of the samples which have generated an interrupt.

Figure 21. Bypass-to-FIFO mode

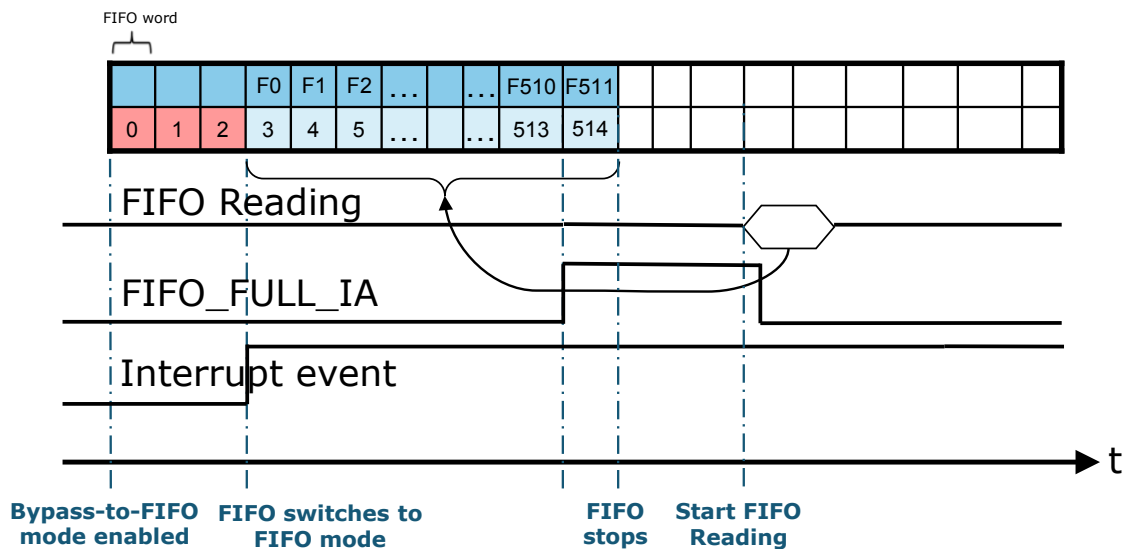

7.7 Retrieving data from the FIFO

When FIFO is enabled and the mode is different from bypass, reading the FIFO output registers return the oldest FIFO sample set. Whenever these registers are read, their content is moved to the SPI/I²C/MIPI I3CSM output buffer.

FIFO slots are ideally shifted up one level in order to release room for a new sample, and the FIFO output registers load the current oldest value stored in the FIFO buffer.

The recommended way to retrieve data from the FIFO is the following:

1. Read the FIFO_STATUS1 and FIFO_STATUS2 registers to check how many words are stored in the FIFO. This information is contained in the DIFF_FIFO_[9:0] bits.
2. For each word in FIFO, read the FIFO word (tag and output data) and interpret it on the basis of the FIFO tag.
3. Go to step 1.

The entire FIFO content is retrieved by performing a certain number of read operations from the FIFO output registers until the buffer becomes empty (DIFF_FIFO_[9:0] bits of the FIFO_STATUS1 and FIFO_STATUS2 register are equal to 0).

It is recommended to avoid reading from FIFO when it is empty.

FIFO output data must be read with multiple of 7 bytes reads starting from the FIFO_DATA_OUT_TAG register. The wraparound function from address FIFO_DATA_OUT_Z_H to FIFO_DATA_OUT_TAG is done automatically in the device, in order to allow reading many words with a unique multiple read operation.

Figure 23. FIFO threshold (STOP_ON_WTM = 1) in FIFO mode

WTM[8:0] = 21
STOP_ON_WTM = 1

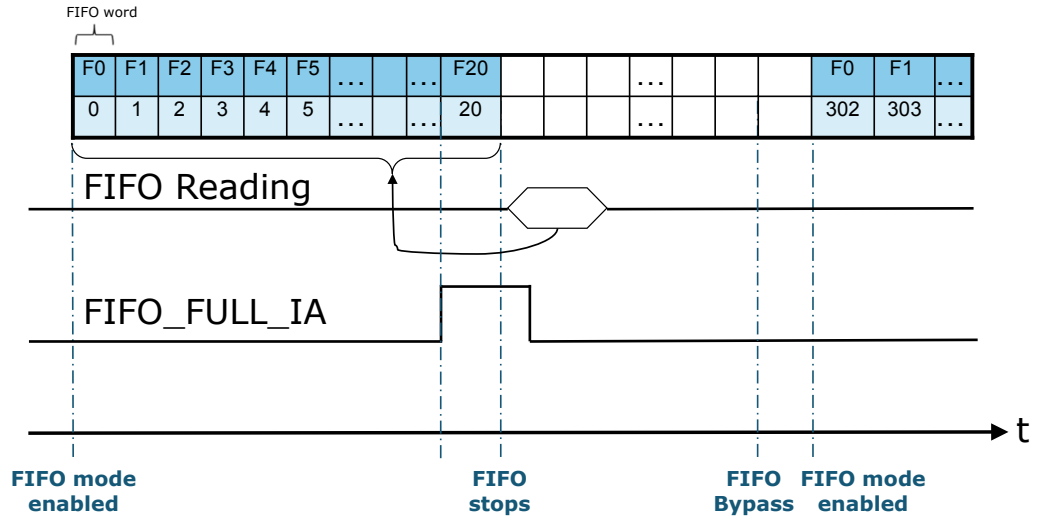

Figure 23. FIFO threshold (STOP_ON_WTM = 1) in FIFO mode shows an example of FIFO threshold level usage in FIFO mode with the STOP_ON_WTM bit set to 1 in the FIFO_CTRL2 register. Just accelerometer (or gyroscope) data are stored in this example. The threshold level is set to 21 through the WTM[8:0] bits and defines the current FIFO size. In FIFO mode, data are stored in the FIFO buffer until the FIFO is full. The FIFO_FULL_IA bit of the FIFO_STATUS2 register rises when the next data stored in the FIFO generates the FIFO full or overrun condition. The FIFO_WTM_IA bit of the FIFO_STATUS2 register goes high when the FIFO is full.

Figure 24. FIFO threshold (STOP_ON_WTM = 1) in Continuous mode

WTM[8:0] = 21
STOP_ON_WTM = 1

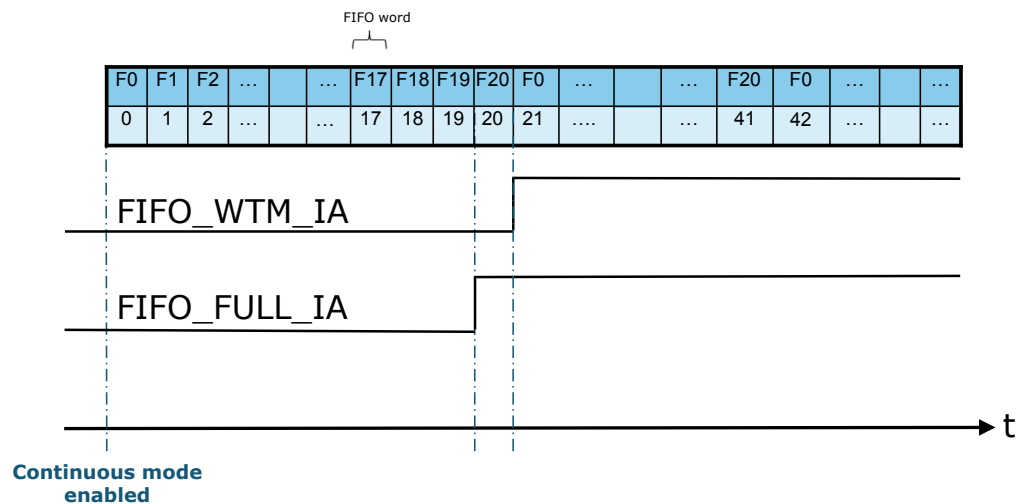

Figure 24. FIFO threshold (STOP_ON_WTM = 1) in Continuous mode shows an example of FIFO threshold level usage in continuous mode with the STOP_ON_WTM bit set to 1 in the FIFO_CTRL2 register. Just accelerometer (or gyroscope) data are stored in this example. The threshold level is set to 21 through the WTM[8:0] bits. The FIFO_FULL_IA bit of the FIFO_STATUS2 register rises when the next data stored in the FIFO makes the FIFO full. The FIFO_WTM_IA bit of the FIFO_STATUS2 goes high when the FIFO is full. If data are not retrieved from FIFO, new data (labeled as sample 21) override the older data stored in FIFO (labeled as sample F0).

7.9 Timestamp correlation

It is possible to reconstruct the timestamp of FIFO stream with three different approaches:

1. Basic, using only timestamp sensor information
2. Memory-saving, based on the TAG_CNT field in FIFO_DATA_OUT_TAG
3. Hybrid, based on combined usage of the TAG_CNT field and decimated timestamp sensor

The basic approach guarantees the highest precision in timestamp reconstruction but wastes a lot of memory space available in FIFO. The timestamp sensor is written in FIFO at each time slot. If the overrun condition occurs, the correct procedure to retrieve the data from FIFO is to discard each data read before a new timestamp sensor.

The memory-saving approach uses only the TAG_CNT information and, when the TAG_CNT value increases, the timestamp stored at the software layer should be updated as follows:

$$timestamp = timestamp(i - 1) + \frac{1}{\max(BDR_{XL}, BDR_{GY})}$$

The memory-saving approach allows the user to maximize the data stored in FIFO. With this method all the timestamp correlation is forwarded to the application processor.

This approach is not recommended when the overrun condition can occur.

The hybrid approach is a trade-off and a combination of the two previous solutions. The timestamp is configured to be written in FIFO with decimation. When the TAG_CNT value increases, the timestamp stored at the software layer should be updated as in the memory-saving approach, while when the timestamp sensor is read, the timestamp stored at the software layer should be realigned with the correct value from the sensor.

8 Temperature sensor

The device is provided with an internal temperature sensor that is suitable for ambient temperature measurement. If both the accelerometer and the gyroscope sensors are in power-down mode, the temperature sensor is off.

The maximum output data rate of the temperature sensor is 52 Hz and its value depends on how the accelerometer and gyroscope sensors are configured:

- If the gyroscope is in power-down mode:
 - If the accelerometer is configured in low-power mode and its ODR is lower than 52 Hz, the temperature data rate is equal to the configured accelerometer ODR.
 - The temperature data rate is equal to 52 Hz for all other accelerometer configurations.
- If the gyroscope is not in power-down mode, the temperature data rate is equal to 52 Hz, regardless of the accelerometer and gyroscope configuration.

For the temperature sensor, the data-ready signal is represented by the TDA bit of the STATUS_REG register. The signal can be driven to the INT2 pin by setting the INT2_DRDY_TEMP bit of the INT2_CTRL register to 1.

The temperature data is given by the concatenation of the OUT_TEMP_H and OUT_TEMP_L registers and it is represented as a number of 16 bits in two's complement format with a sensitivity of 256 LSB/°C. The output zero level corresponds to 25°C.

Temperature sensor data can also be stored in FIFO with a configurable batch data rate (see [Section 7: First-in, first-out \(FIFO\) buffer](#) for details).

8.1 Example of temperature data calculation

The following table provides a few basic examples of the data that is read from the temperature data registers at different ambient temperature values. The values listed in this table are given under the hypothesis of perfect device calibration (that is, no offset, no gain error, and so forth).

Table 49. Content of output data registers vs. temperature

Temperature values	Register address	
	OUT_TEMP_H (21h)	OUT_TEMP_L (20h)
0°C	E7h	00h
25°C	00h	00h
50°C	19h	00h

9 Self-test

The embedded self-test functions allow checking the device functionality without moving it.

9.1 Accelerometer self-test

When the accelerometer self-test is enabled, an actuation force is applied to the sensor, simulating a definite input acceleration. In this case, the sensor outputs exhibit a change in their DC levels which are related to the selected full scale through the sensitivity value.

The accelerometer self-test function is off when the ST[1:0]_XL bits of the CTRL5_C register are programmed to 00. It is enabled when the ST[1:0]_XL bits are set to 01 (positive sign self-test) or 10 (negative sign self-test).

When the accelerometer self-test is activated, the sensor output level is given by the algebraic sum of the signals produced by the acceleration acting on the sensor and by the electrostatic test-force.

The complete accelerometer self-test procedure is indicated in [Figure 25. Accelerometer self-test procedure](#).

Figure 25. Accelerometer self-test procedure

Accelerometer self-test

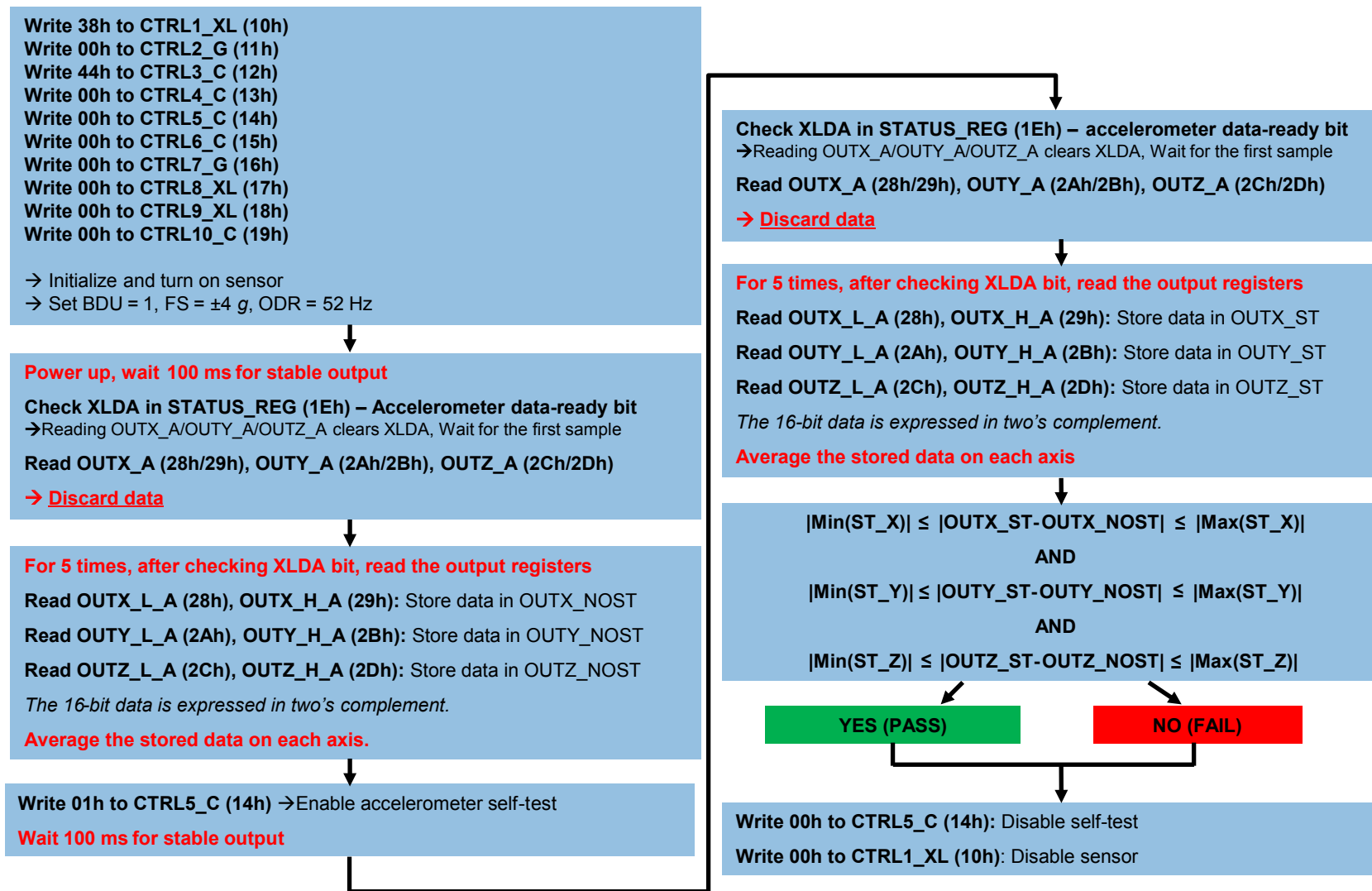

9.2 Gyroscope self-test

The gyroscope self-test allows testing the mechanical and electrical parts of the gyroscope sensor. When it is activated, an equivalent Coriolis signal is emulated at the input of the ASIC front-end and the sensor output exhibits an output change.

The gyroscope self-test function is off when the ST[1:0]_G bits of the CTRL5_C register are programmed to 00. It is enabled when the ST[1:0]_G bits are set to 01 (positive sign self-test) or 11 (negative sign self-test).

When the gyroscope self-test is active, the sensor output level is given by the algebraic sum of the signals produced by the angular rate acting on the sensor and by the electrostatic test-force.

The complete gyroscope self-test procedure is indicated in [Figure 26. Gyroscope self-test procedure](#).

Figure 26. Gyroscope self-test procedure

Gyroscope self-test

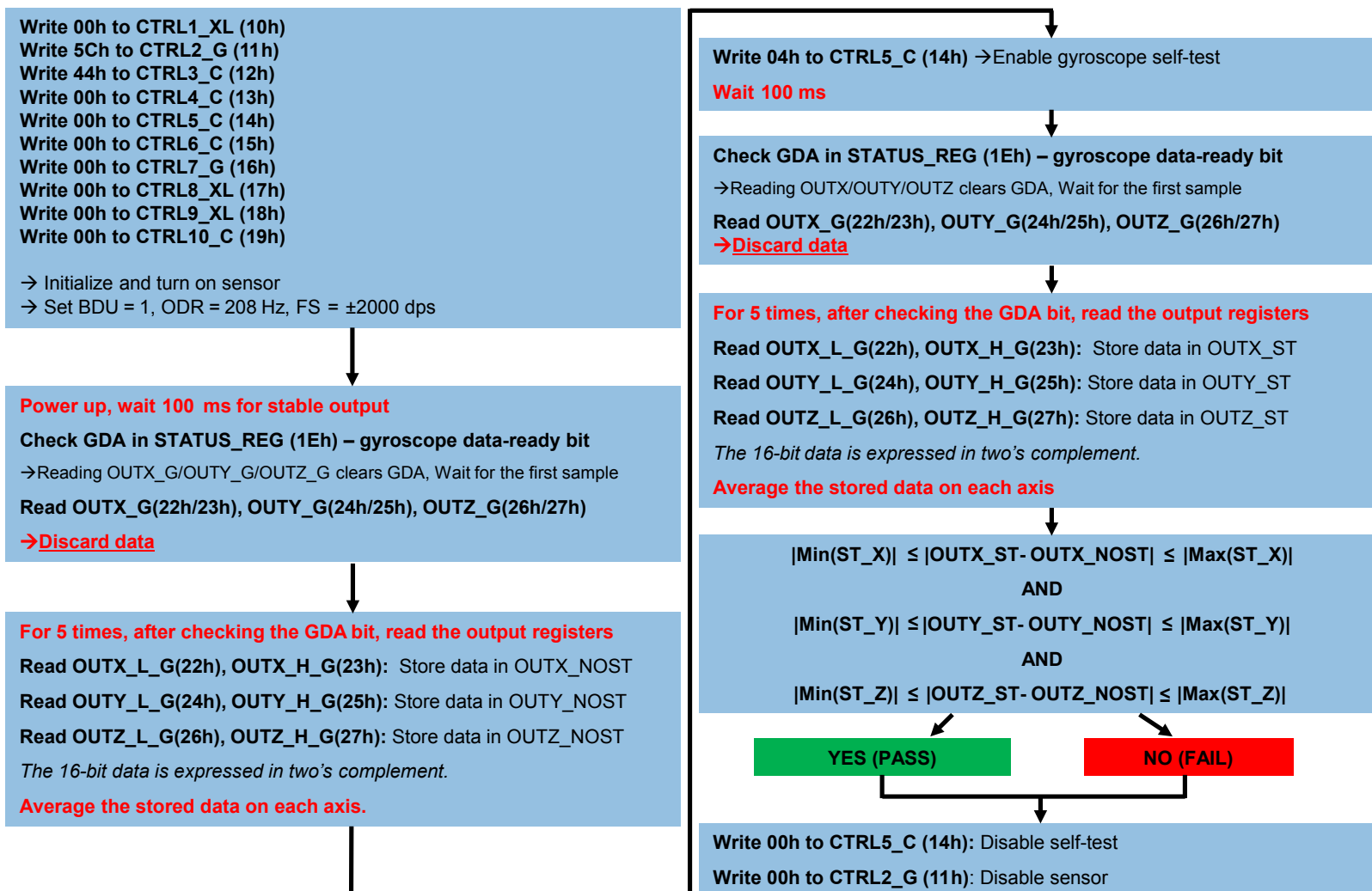

Revision history

Table 50. Document revision history

Date	Version	Changes
09-Feb-2024	1	Initial release

Contents

1	Pin description	2
2	Registers	4
2.1	Embedded functions registers	7
2.2	Embedded advanced features pages	9
3	Operating modes	10
3.1	Power-down mode	13
3.2	High-performance mode	13
3.3	Low-power mode	13
3.4	Gyroscope sleep mode	13
3.5	Accelerometer bandwidth	14
3.5.1	Accelerometer slope filter	16
3.6	Accelerometer turn-on/off time	16
3.7	Gyroscope bandwidth	18
3.8	Gyroscope turn-on/off time	21
4	Reading output data	23
4.1	Startup sequence	23
4.2	Using the status register	23
4.3	Using the data-ready signal	24
4.3.1	DRDY mask functionality	24
4.4	Using the block data update (BDU) feature	24
4.5	Understanding output data	25
4.5.1	Examples of output data	25
4.6	Accelerometer offset registers	26
4.7	Wraparound functions	26
4.7.1	FIFO output registers	26
4.7.2	Sensor output registers	26
4.8	DEN (data enable)	27
4.8.1	Edge-sensitive trigger mode	28
4.8.2	Level-sensitive trigger mode	30
4.8.3	Level-sensitive latched mode	31
4.8.4	Level-sensitive FIFO enable mode	32
4.8.5	LSB selection for DEN stamping	32
5	Interrupt generation	33
5.1	Interrupt pin configuration	33
5.2	Free-fall interrupt	36

5.3	Wake-up interrupt	37
5.4	6D/4D orientation detection	39
5.4.1	6D orientation detection	39
5.4.2	4D orientation detection	41
5.5	Activity/inactivity and motion/stationary recognition	41
5.5.1	Stationary/motion detection	43
5.6	Boot status	44
6	Timestamp	45
7	First-in, first-out (FIFO) buffer	46
7.1	FIFO description and batched sensors	47
7.2	FIFO registers	47
7.2.1	FIFO_CTRL1	48
7.2.2	FIFO_CTRL2	48
7.2.3	FIFO_CTRL3	49
7.2.4	FIFO_CTRL4	50
7.2.5	COUNTER_BDR_REG1	51
7.2.6	COUNTER_BDR_REG2	51
7.2.7	FIFO_STATUS1	51
7.2.8	FIFO_STATUS2	52
7.2.9	FIFO_DATA_OUT_TAG	53
7.2.10	FIFO_DATA_OUT	53
7.3	FIFO batched sensors	54
7.4	Main sensors	54
7.5	Auxiliary sensors	55
7.6	FIFO modes	57
7.6.1	Bypass mode	57
7.6.2	FIFO mode	58
7.6.3	Continuous mode	59
7.6.4	Continuous-to-FIFO mode	60
7.6.5	Bypass-to-continuous mode	61
7.6.6	Bypass-to-FIFO mode	62
7.7	Retrieving data from the FIFO	63
7.8	FIFO watermark threshold	64
7.9	Timestamp correlation	67
8	Temperature sensor	68
8.1	Example of temperature data calculation	68
9	Self-test	69

9.1	Accelerometer self-test.....	69
9.2	Gyroscope self-test.....	71
	Revision history.....	73
	List of tables.....	77
	List of figures.....	78

List of tables

Table 1.	Pin status	3
Table 2.	Registers	4
Table 3.	Embedded functions registers	7
Table 4.	Embedded advanced features registers - page 1	9
Table 5.	Accelerometer ODR and power mode selection	11
Table 6.	Gyroscope ODR and power mode selection	11
Table 7.	Power consumption at Vdd = 3.0 V, T = 25°C	12
Table 8.	Power consumption at Vdd = 1.8 V, T = 25°C	12
Table 9.	Accelerometer bandwidth selection	15
Table 10.	Accelerometer turn-on/off time (LPF2 and HP disabled)	17
Table 11.	Accelerometer samples to be discarded	17
Table 12.	Gyroscope digital HP filter cutoff selection	18
Table 13.	Gyroscope overall bandwidth selection	18
Table 14.	Gyroscope turn-on/off time (HP disabled)	21
Table 15.	Gyroscope samples to be discarded (LPF1 disabled)	21
Table 16.	Gyroscope chain settling time (LPF1 enabled)	22
Table 17.	Content of output data registers vs. acceleration (FS_XL = ±2 g)	25
Table 18.	Content of output data registers vs. angular rate (FS_G = ±250 dps)	25
Table 19.	Output register wraparound pattern	26
Table 20.	DEN configurations	27
Table 21.	INT1_CTRL register	33
Table 22.	MD1_CFG register	34
Table 23.	INT2_CTRL register	34
Table 24.	MD2_CFG register	34
Table 25.	Free-fall threshold LSB value	36
Table 26.	D6D_SRC register	39
Table 27.	Threshold for 4D/6D function	40
Table 28.	D6D_SRC register in 6D positions	41
Table 29.	Inactivity event configuration	42
Table 30.	ODR _{coeff} values	45
Table 31.	FIFO_CTRL1 register	48
Table 32.	FIFO_CTRL2 register	48
Table 33.	FIFO_CTRL3 register	49
Table 34.	Accelerometer batch data rate	49
Table 35.	Gyroscope batch data rate	49
Table 36.	Timestamp batch data rate	50
Table 37.	Temperature sensor batch data rate	50
Table 38.	FIFO_CTRL4 register	50
Table 39.	COUNTER_BDR_REG1 register	51
Table 40.	COUNTER_BDR_REG2 register	51
Table 41.	FIFO_STATUS1 register	51
Table 42.	FIFO_STATUS2 register	52
Table 43.	FIFO_DATA_OUT_TAG register	53
Table 44.	TAG_SENSOR field and associated sensor	53
Table 45.	Main sensors output data format in FIFO	54
Table 46.	Temperature output data format in FIFO	55
Table 47.	Timestamp output data format in FIFO	55
Table 48.	CFG-change output data format in FIFO	56
Table 49.	Content of output data registers vs. temperature	68
Table 50.	Document revision history	73

List of figures

Figure 1.	Pin connections	2
Figure 2.	Accelerometer filtering chain	14
Figure 3.	Accelerometer slope filter.	16
Figure 4.	Gyroscope digital chain	18
Figure 5.	Data-ready signal	24
Figure 6.	Edge-sensitive trigger mode, DEN active-low	28
Figure 7.	Level-sensitive trigger mode, DEN active-low	30
Figure 8.	Level-sensitive trigger mode, DEN active-low, DEN_DRDY on INT1	30
Figure 9.	Level-sensitive latched mode, DEN active-low	31
Figure 10.	Level-sensitive latched mode, DEN active-low, DEN_DRDY on INT1.	31
Figure 11.	Level-sensitive FIFO enable mode, DEN active-low.	32
Figure 12.	Free-fall interrupt	36
Figure 13.	Wake-up interrupt (using the slope filter)	38
Figure 14.	6D recognized orientations.	40
Figure 15.	Activity/inactivity recognition (using the slope filter)	43
Figure 16.	Main sensors and time slot definitions	54
Figure 17.	FIFO mode (STOP_ON_WTM = 0)	58
Figure 18.	Continuous mode	59
Figure 19.	Continuous-to-FIFO mode	60
Figure 20.	Bypass-to-continuous mode	61
Figure 21.	Bypass-to-FIFO mode	62
Figure 22.	FIFO threshold (STOP_ON_WTM = 0)	64
Figure 23.	FIFO threshold (STOP_ON_WTM = 1) in FIFO mode	65
Figure 24.	FIFO threshold (STOP_ON_WTM = 1) in Continuous mode	65
Figure 25.	Accelerometer self-test procedure.	70
Figure 26.	Gyroscope self-test procedure	72

IMPORTANT NOTICE – READ CAREFULLY

STMicroelectronics NV and its subsidiaries (“ST”) reserve the right to make changes, corrections, enhancements, modifications, and improvements to ST products and/or to this document at any time without notice. Purchasers should obtain the latest relevant information on ST products before placing orders. ST products are sold pursuant to ST’s terms and conditions of sale in place at the time of order acknowledgment.

Purchasers are solely responsible for the choice, selection, and use of ST products and ST assumes no liability for application assistance or the design of purchasers’ products.

No license, express or implied, to any intellectual property right is granted by ST herein.

Resale of ST products with provisions different from the information set forth herein shall void any warranty granted by ST for such product.

ST and the ST logo are trademarks of ST. For additional information about ST trademarks, refer to www.st.com/trademarks. All other product or service names are the property of their respective owners.

Information in this document supersedes and replaces information previously supplied in any prior versions of this document.

© 2024 STMicroelectronics – All rights reserved