

# STACF01 non-complementary Active Clamp Flyback controller demonstration board

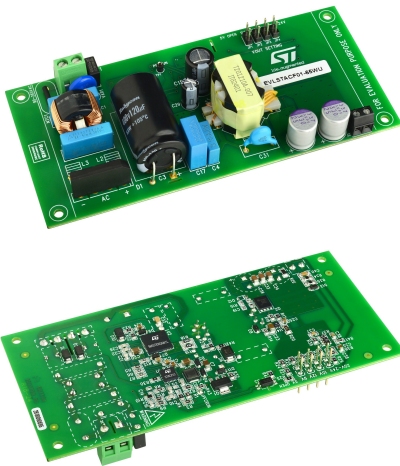

## Features

- Universal AC input voltage: 90~264 VAC, 47~63 Hz
- Maximum output power: 65 W
- Selectable output voltage: 5-9-12-15-20 VDC
- Peak efficiency: 93.7% full load @230 VAC
- Standby power consumption:
  - 46 mW@115 VAC
  - 62 mW@230 VAC
- Key products: STACF01, MasterGaN1L, SRK1004

## Applications

- AC-DC adapters for smartphones, laptops, and other handheld devices
- Offline SMPS

## Description

The **EVLSTACF01-65WU** is a 65 W Active Clamp Flyback (ACF) converter designed to evaluate the STACF01, ACF controller. The board can receive a universal AC input voltage and provides a selectable output voltage based on the USB PD specifications, from 5 V to 20 V.

At the primary side, the STACF01 is paired with the MasterGaN1L, a 600 V half-bridge enhancement mode GaN HEMT with high-voltage drivers.

The STACF01 integrates a buck boost that allows to achieve low standby power consumption with a single transformer's auxiliary winding.

A synchronous rectification based on the SRK1004 is employed at the secondary side to enhance the efficiency.

The STACF01 integrates an 800 V rated high-voltage startup, and offers a full set of protections and features, such as AC-brownout, X-CAP discharge, overload and short-circuit protection, output overvoltage protection.

### Product status link

[EVLSTACF01-65WU](#)

### Product summary

65 W ACF converter	EVLSTACF01-65WU
ACF controller	STACF01
MasterGaN1L	600 V half-bridge enhancement mode GaN HEMT with high-voltage driver
SRK1004	Synchronous rectifier controller for ACF

# 1 Schematic

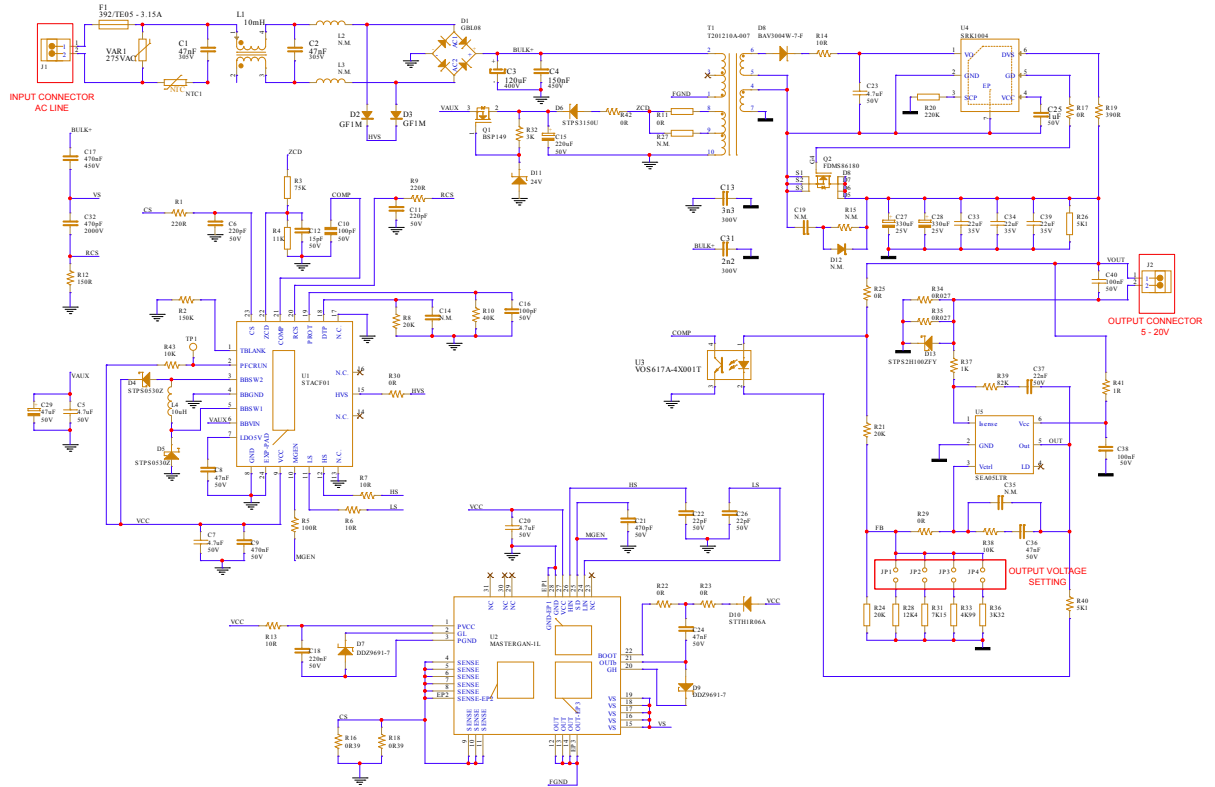
**Figure 1. EVLSTACF01-65WU - schematic**

**Table 1. EVLSTACF01-65WU - bill of material**

Part reference	Part description	Manufacturer	Part number	Value
C1,C2	X2 film cap	Epcos	B32932A3473K000	47nF
C3	400V aluminum cap	Rubycon	400KXW120MEFC 18X30	120µF
C4	450V film cap	TDK	MKP B32671P4154K000	150nF
C5,C7,C20,C23	50V MLCC X7R	Murata	GRM31CR71H475K A12L	4.7µF
C6,C11	50V MLCC X7R	Kemet	C0805C221J5GACTU	220pF
C8,C24,C36	50V MLCC X7R	Kemet	C0805C473K5RACTU	47nF
C9	50V MLCC X7R	Kemet	C0805C474K5RACTU	470nF
C10	MLCC ±5%	Walsin	0805N101J500CT	100pF
C12	50V MLCC X7R	Samsung	CL21C150JB61PNC	15pF
C13	300V Y1 safety cap	Murata	DE1E3RA332MN4AP01F	3.3nF
C14,C35	0805	-	-	N.M.
C15	50V electrolytic cap	Panasonic	EEUFR1H221	220µF
C16	50V MLCC X7R	Walsin	0805N101J500CT	100pF
C17	450V PPC	Epcos	B32671P4474K000	470nF

Part reference	Part description	Manufacturer	Part number	Value
C18	50V MLCC X7R	Samsung	CL21B224KBFSFNE	220nF
C19	1206	-	-	N.M.
C21	50V MLCC X7R	Kemet	C0805C471J5GACTU	470pF
C22,C26	50V MLCC X7R	AVX	08051A220KAT2A	22pF
C25	50V MLCC X7R	Taiyo Yuden	UMK212B7105KG-T	1µF
C27,C28	25V OSCON	Panasonic	25SEPF330M	330µF
C29	50V electrolytic cap	Rubycon	50YXF47MEFC6.3X11	47µF
C31	300V Y1 safety cap	Murata	DE1E3KX222MN4AP01F	2.2nF
C32	2kV MLCC X7R	Johanson	202R18W471KV4E	470pF
C33,C34 C39	35V MLCC X5R	C3216X5R1V226M	C3216X5R1V226M 160AC	22µF
C37	50V MLCC X7R	Multicomp	MC0805B223K500CT	22nF
C38	50V MLCC X7R	Kemet	C0805C104K5RACTU	100nF
C40	50V MLCC X7R	Kemet	C1206C104K5RAC7800	100nF
D1	800V bridge rectifier	GeneSiC Semiconductor	GBL08	-
D2,D3	1kV 1A	ON Semiconductor	GF1M	-
D4,D5	30V 0.5A	STMicroelectronics	STPS0530Z	-
D6	150V 3A	STMicroelectronics	STPS3150U	-
D7,D9	6V2 Zener	Diodes Incorporated	DDZ9691-7	-
D8	350V 0.225A	Diodes Incorporated	BAV3004W-7-F	-
D10	600V 1A	STMicroelectronics	STTH1R06A	-
D11	24V Zener	ON Semiconductor	MMSZ4709T1G	-
D12	SOT-123	-	-	N.M.
D13	100V 2A	STMicroelectronics	STPS2H100ZFY	-
L1	Common mode choke	ITG Electronics	C201517BQ-103	10mH
L2,L3	Inductor	Würth	7447051	N.M.
L4	Inductor	Würth	74406042100	10µH
T1	Transformer	ITG Electronics	T201210A-007	RM8
F1	250V 3.15A fuse	Littelfuse	39213150000	-
J1	5.08mm pitch	Phoenix	MKDS 1,5/ 2-5,08	-
J2	3.81mm pitch	Phoenix	MKDS 1/2-3,81 HT BK	-
NTC1	7.5mm pitch	Epcos	B57237S0109M	Shorted
VAR1	7.5mm pitch	TDK	B72210S0271K101	-
Q1	Depletion N-channel MOSFET	Infineon Technologies	BSP149	-
Q2	100V 151A MOSFET	ON Semiconductor	FDMS86180	-
R1,R9	0805	Yageo	RC0805FR-07220RL	220R
R2	0805	Multicomp	MC01W08051150K	150K
R3	0805	Vishay	CRCW080575K0FKEA	75K
R4	0805	Yageo	RC0805FR-0711KL	11K
R5	0805	Yageo	RC0805FR-07100RL	100R
R6,R7,R13R14	0805	-	-	10R

Part reference	Part description	Manufacturer	Part number	Value
R8,R21,R24	0805	Yageo	RC0805FR-0720KL	20K
R10	0805	Vishay	CRCW080540K0FKEA	40K
R11,R17 R22,R23 R25,R29 R30,R42	0805	Yageo	RC0805JR-070RL	0R
R12	0805	Walsin	WR08X1500FTL	150R
R15	1206	-	-	N.M.
R16,R18	1206	Panasonic	ERJ-8RQFR39V	0R39
R19	0805	-	-	390R
R20	1206	ROHM Semiconductor	ESR18EZPJ224	220K
R26	1206	Vishay	CRCW12065K10FKEA	5K1
R27	0805	-	-	N.M.
R28	0805	Yageo	RC0805FR-0712K4L	12K4
R31	0805	Yageo	RC0805FR-077K15L	7K15
R32	0805	Yageo	RC0805FR-073KL	3K
R33	0805	Yageo	RC0805FR-074K99L	4K99
R34,R35	1206	Panasonic	ERJ-8BWFR027V	0R027
R36	0805	Yageo	RC0805FR-073K32L	3K32
R37	0805	Yageo	RC0805FR-071KL	1K
R38,R43	0805	Yageo	RC0805FR-0710KL	10K
R39	0805	Yageo	RC0805FR-0782KL	82K
R40	0805	Vishay	CRCW08055K10FKEA	5K1
R41	0805	Walsin	WR08W1R00FTL	1R
U1	ACF controller	STMicroelectronics	STACF01	QFN 5x5
U2	600V GaN + driver	STMicroelectronics	MASTERGAN1L	VFQFPN31L9x9x1-34P
U3	Optocoupler	Vishay	VOS617A-4X001T	SSOP-4
U4	SR controller	STMicroelectronics	SRK1004	DFN6
U5	CC/CV controller	STMicroelectronics	SEA05L	SOT23

---

## 2 Waste and recycling

---

**The evaluation board is not to be disposed of as an urban waste. At the end of its life cycle, differentiated waste collection must be followed.** Consult the local authorities for more information on the proper disposal channels and recycling centers. It is mandatory to collect separately the Evaluation Board and make sure it is delivered to the appropriate waste management and recycling centers. As of 15 August 2018, in all countries belonging to the European Union, the Evaluation Board is subject to the requirements of WEEE Directive **2012/19/EU**, and therefore it is forbidden to dispose of the Evaluation Board as undifferentiated waste or with other domestic waste. Incorrect disposal of the Evaluation Board may cause damage to the environment and may incur fines based on specific countries' rules, regulations, and laws.

## Revision history

**Table 2. Document revision history**

Date	Version	Changes
05-Dec-2024	1	Initial release.



## Contents

<b>1</b>	<b>Schematic</b> .....	<b>2</b>
<b>2</b>	<b>Waste and recycling</b> .....	<b>5</b>
	<b>Revision history</b> .....	<b>6</b>
	<b>List of tables</b> .....	<b>8</b>
	<b>List of figures</b> .....	<b>9</b>



## List of tables

<b>Table 1.</b>	EVLSTACF01-65WU - bill of material . . . . .	2
<b>Table 2.</b>	Document revision history . . . . .	6





## List of figures

Figure 1. EVLSTACF01-65WU - schematic ..... 2

**IMPORTANT NOTICE – READ CAREFULLY**

STMicroelectronics NV and its subsidiaries (“ST”) reserve the right to make changes, corrections, enhancements, modifications, and improvements to ST products and/or to this document at any time without notice. Purchasers should obtain the latest relevant information on ST products before placing orders. ST products are sold pursuant to ST’s terms and conditions of sale in place at the time of order acknowledgment.

Purchasers are solely responsible for the choice, selection, and use of ST products and ST assumes no liability for application assistance or the design of purchasers’ products.

No license, express or implied, to any intellectual property right is granted by ST herein.

Resale of ST products with provisions different from the information set forth herein shall void any warranty granted by ST for such product.

ST and the ST logo are trademarks of ST. For additional information about ST trademarks, refer to [www.st.com/trademarks](http://www.st.com/trademarks). All other product or service names are the property of their respective owners.

Information in this document supersedes and replaces information previously supplied in any prior versions of this document.

© 2024 STMicroelectronics – All rights reserved