

Half-bridge evaluation board for STGAP3SXS SiC MOSFETs isolated gate driver with protections

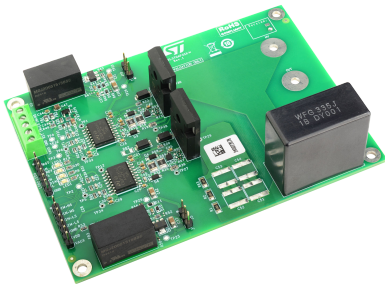

Product status link

[EVLSTGAP3SXS-H](#)

Features

- **Board**
 - Half-bridge configuration
 - High-voltage rail up to 520 V (limited by the MOSFET's and capacitor's rating)
 - SCTWA70N120G2V-4 SiC MOSFETs: 1200 V, 30 mΩ, 91 A
 - Compatible with 5 V and 3.3 V MCUs
 - VDD logic supplied by onboard-generated 3.3 V or VAUX = 5 V
 - Onboard isolated DC-DC converters to supply high-side and low-side gate drivers, fed by VAUX = 5 V, with 5.2 kV_{pk} maximum isolation
 - Easy jumper selection of driving voltage configuration: +19/0 V; +19/-4.7 V; +17/0 V; +17/-4.7 V
 - Fault LED indicators
 - Maximum working voltage across isolation: 1200 V
 - RoHS compliant
- **STGAP3SXS device**
 - Driver current capability: 10 A source/sink @ 25 °C
 - 75 ns input-output propagation delay
 - Miller CLAMP driver for external N-channel MOSFET
 - Adjustable soft turn-off function
 - UVLO function
 - Desaturation protection
 - Gate driving voltage up to 32 V
 - Negative gate driving voltage
 - 3.3 V, 5 V TTL/CMOS inputs with hysteresis
 - Temperature shutdown protection
 - Reinforced galvanic isolation:
 - Isolation voltage $V_{ISO} = 5.7 \text{ kV}_{RMS}$ (UL 1577)
 - Transient overvoltage $V_{IOTM} = 8 \text{ kV}_{PEAK}$ (IEC 60747-17)
 - Max. repetitive isolation voltage $V_{IORM} = 1.2 \text{ kV}_{PEAK}$ (IEC 60747-17)

Description

The EVLSTGAP3SXS-H is a half-bridge evaluation board designed to evaluate the STGAP3SXS isolated single gate driver.

The STGAP3SXS is characterized by 10 A current capability, rail-to-rail outputs and optimized UVLO and DESAT protection thresholds for SiC MOSFETs, which makes the device optimal for high-power motor drivers in industrial applications.

The gate driver has a single output pin and a driver line for an external Miller CLAMP N-channel MOSFET, which optimizes positive and negative gate spikes' suppression during fast commutations in half-bridge topologies.

The board is supplied by the 5 V VAUX connection, which fed the isolated DC-DC converters for the low-side and high-side driving sections. The gate drivers can be directly supplied by VAUX if a 5 V MCU is used, or by the onboard linear regulator if a 3.3 V MCU is used. The PWM and Reset inputs can be easily controlled through dedicated connectors while diagnostic outputs are connected to an onboard LED.

Device protection features (Desaturation, Soft turn-off, and Miller clamp) are connected to the recommended network on the board and can be easily evaluated through the board test points.

Dual input pins allow the selection of signal polarity control and implementation of HW interlocking protection to avoid cross-conduction in case of controller malfunction.

The device allows implementing negative gate driving, and the onboard isolated DC-DC converters allow working with optimized driving voltage for SiC MOSFETs.

The EVLSTGAP3SXS-H board allows evaluating all of the STGAP3SXS features while operating with a bus voltage up to 520 V. It is possible to increase the bus voltage up to 1200 V by replacing the two SiC MOSFETs with appropriate devices in a HiP247-4 package and the C4 capacitance if needed.

1 Safety and operating instructions



1.1 General terms

Warning: *During assembly, testing, and operation, the evaluation board poses several inherent hazards, including bare wires, moving or rotating parts, and hot surfaces.*

Danger: *There is a danger of serious personal injury, property damage, or death due to electrical shock and burn hazards if the kit or components are improperly used or installed incorrectly.*

Attention: *The kit is not electrically isolated from the high-voltage supply DC input. No insulation is ensured between the accessible parts and the high voltage. All measuring equipment must use adequately insulated probes, clamps, and connecting wires. Never touch the evaluation board while it is energized as it is capable of causing an electrical shock hazard.*

Important: *All operations involving transportation, installation and use, and maintenance must be performed by skilled technical personnel able to understand and implement national accident prevention regulations. For the purposes of these basic safety instructions, "skilled technical personnel" are suitably qualified people who are familiar with the installation, use, and maintenance of power electronic systems.*

1.2 Intended use of evaluation board

The evaluation board is designed for demonstration purposes only, and must not be used for electrical installations or machinery. Technical data and information concerning the power supply conditions are detailed in the documentation and should be strictly observed.

1.3 Installing the evaluation board

- The installation and cooling of the evaluation board must be in accordance with the specifications and target application.
- The board must be protected against excessive strain. In particular, components should not be bent nor should isolating distances be altered during transportation or handling.
- No contact must be made with other electronic components and contacts.
- The board contains electrostatically sensitive components that are prone to damage if used incorrectly. Do not mechanically damage or destroy the electrical components (potential health risks).

1.4 Operating the evaluation board

To properly operate the board, follow these safety rules.

1. Work area safety:
 - The work area must be clean and tidy.
 - Do not work alone when boards are energized.
 - Protect against inadvertent access to the area where the board is energized using suitable barriers and signs.
 - A system architecture that supplies power to the evaluation board must be equipped with additional control and protective devices in accordance with the applicable safety requirements (that is, compliance with technical equipment and accident prevention rules).
 - Use a non-conductive and stable work surface.
 - Use adequately insulated clamps and wires to attach measurement probes and instruments.
2. Electrical safety:
 - Remove the power supply from the board and electrical loads before taking any electrical measurements.
 - Proceed with the arrangement of measurement setup, wiring, or configuration paying attention to high-voltage sections.
 - Once the setup is complete, energize the board.

Danger: *Do not touch the board when it is energized or immediately after it has been disconnected from the voltage supply as several parts and power terminals containing potentially energized capacitors need time to discharge.
Do not touch the board after disconnection from the voltage supply as several parts, including the PCB, may still be very hot.
The kit is not electrically isolated from DC input.*

3. Personal safety:
 - Always wear suitable personal protective equipment such as insulating gloves and safety glasses.
 - Take adequate precautions and install the board in such a way to prevent accidental touch. Use protective shields such as, for example, an insulating box with interlocks if necessary.

2 Schematic diagrams

Figure 1. EVLSTGAP3SXS-H schematic diagram - gate driver stage

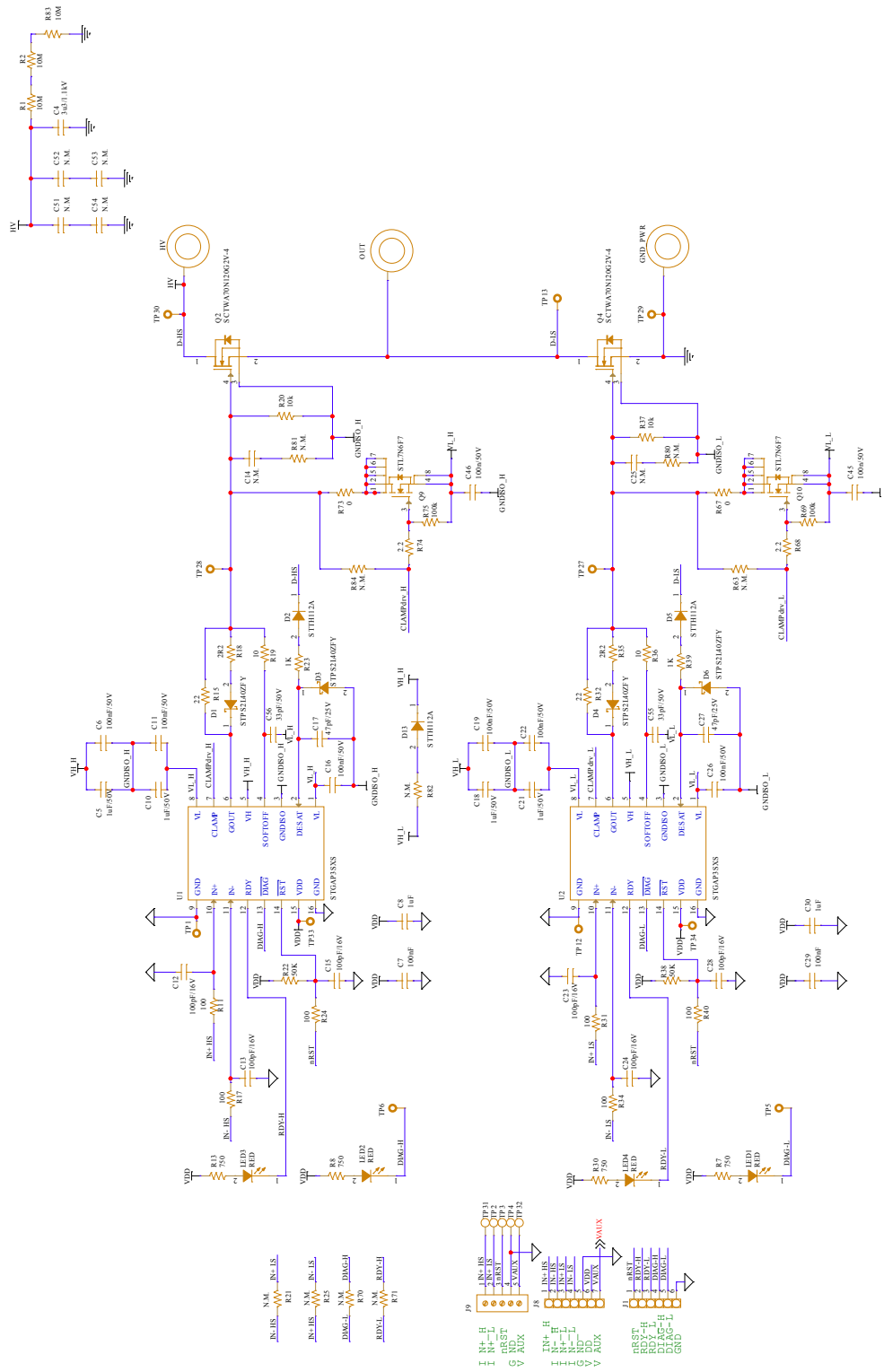
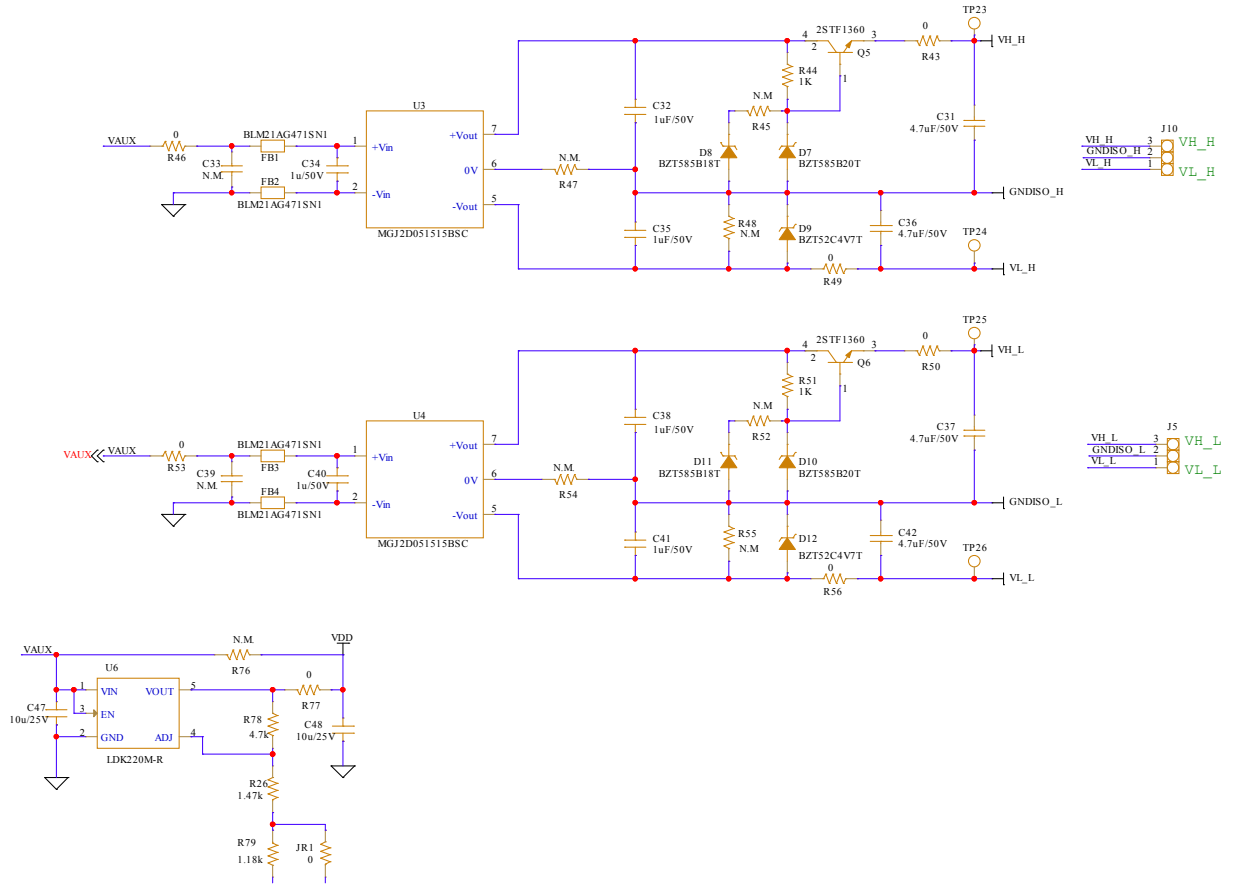

Figure 2. EVLSTGAP3SXS-H schematic diagram - power supplies



3 Bill of materials

Table 1. EVLSTGAP3SXS-H bill of materials

Part reference	Part description	Part value	Package / manufacturer' code
C4	Film capacitor	3.3 μ F / 1.1 kV	Pitch 27.5 mm Panasonic ECWFG1B335J
C5, C10, C18, C21	SMT ceramic capacitor	1 μ F / 50 V	Size 0603
C6, C11, C16, C19, C22, C26	SMT ceramic capacitor	100 nF / 50 V	Size 0603
C7, C29	SMT ceramic capacitor	100 nF	Size 0603
C8, C30	SMT ceramic capacitor	1 μ F	Size 0603
C12, C13, C15, C23, C24, C28	SMT ceramic capacitor	100 pF / 16 V	Size 0603
C14, C25	SMT ceramic capacitor	N.M.	Size 0603
C17, C27	SMT ceramic capacitor	47 pF / 25 V	Size 0603
C31, C36, C37, C42	SMT ceramic capacitor	4.7 μ F / 50 V	Size 1206
C32, C35, C38, C41	SMT ceramic capacitor	1 μ F / 50 V	Size 0603
C33, C39	SMT ceramic capacitor	N.M.	Size 0603
C34, C40	SMT ceramic capacitor	1 μ F / 50 V	Size 0603
C45, C46	SMT ceramic capacitor	100 nF / 50 V	Size 0603
C47, C48	SMT ceramic capacitor	10 μ F / 25 V	Size 0805
C51, C52, C53, C54	SMT ceramic capacitor	N.M.	Size 2225
C55, C56	SMT ceramic capacitor	33 pF / 50 V	Size 0402
D1, D3, D4, D6	Automotive low drop power Schottky rectifier	STPS2L40ZFY	SOD123Flat STMicroelectronics STPS2L40ZFY or equivalent
D2, D5, D13	Diode Ultrafast 1200 V, 1 A	STTH112A	SMA STMicroelectronics STTH112A or equivalent
D7, D10	Surface mount precision Zener diode	BZT585B20T	SOD523 Diodes Incorporated BZT585B20T or equivalent
D8, D11	Surface mount precision Zener diode	BZT585B18T	SOD523 Diodes Incorporated BZT585B18T or equivalent
D9, D12	200 mW Zener diode 4.7 V	BZT52C4V7T	SOD523 MCC BZT52C4V7T-TP or equivalent
FB1, FB2, FB3, FB4	Ferrite beads	BLM21AG471SN1	Size 0805 Murata BLM21AG471SN1 or equivalent
JR1, R46, R53	SMT resistor	0 Ω	Size 0603
J1	Strip connector	1x6 pins	Pitch 2.54 mm Würth Elektronik 61300611121 or equivalent

Part reference	Part description	Part value	Package / manufacturer' code
J5, J10	Strip connector	1x3 pins	Pitch 2.54 mm Würth Elektronik 61300311121 or equivalent
J8	Strip connector	1x7 pins	Pitch 2.54 mm Amphenol FCI 68000-407HLF or equivalent
J9	Terminal block T.H.	5 poles	Pitch 3.5 mm Würth Elektronik 691243110005 or equivalent
LED1, LED2, LED3, LED4	WL-SMCW SMT mono-color chip LED waterclear	RED	Size 0805 Würth Elektronik 150080RS75000 or equivalent
Q2, Q4	Silicon carbide power MOSFET 1200 V, 21 mΩ typ., 91 A	SCTWA70N120G2V-4	HiP247-4 STMicroelectronics SCTWA50N120-4 or equivalent
Q5, Q6	Low-voltage fast-switching NPN power transistors	2STF1360	SOT-89 STMicroelectronics 2STF1360 or equivalent
Q9, Q10	N-channel 60 V, 21 mΩ typ., 7 A STripFET F7 power MOSFET	STL7N6F7	PowerFLAT 2x2 mm STMicroelectronics STL7N6F7 or equivalent
R1, R2, R83	SMT resistor	10 MΩ	Size 1206
R7, R8, R13, R30	SMT resistor	750 Ω	Size 0603
R11, R17, R24, R31, R34, R40	SMT resistor	100 Ω	Size 0603
R15, R32	SMT resistor	22 Ω	Size 1210
R18, R35	SMT resistor	2.2 Ω	Size 1210
R19, R36	SMT resistor	10 Ω	Size 0805
R20, R37	SMT resistor	10 kΩ	Size 0402
R21, R25, R47, R54, R63, R70, R71, R76, R80, R81, R84	SMT resistor	N.M.	Size 0402
R22, R38	SMT resistor	50 kΩ	Size 0603
R23, R39	SMT resistor	1 kΩ	Size 0603
R26	SMT resistor	1.47 kΩ	Size 0603
R43, R49, R50, R56, R67, R73, R77	SMT resistor	0 Ω	Size 0402
R44, R51	SMT resistor	1 kΩ	Size 0603
R45, R52	SMT resistor	N.M.	Size 0402
R48, R55	SMT resistor	N.M.	Size 0603
R68, R74	SMT resistor	2.2 Ω	Size 0402
R69, R75	SMT resistor	100 kΩ	Size 0402
R78	SMT resistor	4.7 kΩ	Size 0603
R79	SMT resistor	1.18 kΩ	Size 0603
R82	SMT resistor	N.M.	Size 1206

Part reference	Part description	Part value	Package / manufacturer' code
TP1, TP5, TP6, TP12, TP13, TP27, TP28, TP29, TP30, TP33, TP34	Test point for probe	-	Metalized hole 0.8 mm, diameter 1.27 mm
TP2, TP3, TP4, TP23, TP24, TP25, TP26, TP31, TP32	Test point for probe	-	Copper pad diameter 1.5 mm
U1, U2	Galvanically isolated 10 A single gate driver	STGAP3SXS	SO-16W STMicroelectronics
U3, U4	5.4 kVDC isolated 2 W gate drive DC-DC converter	MGJ2D051515BSC	Murata MGJ2D051515BSC or equivalent
U6	200 mA low quiescent current and low noise LDO	LDK220M-R	SOT23-5L STMicroelectronics LDK220M-R or equivalent

4 Layout and component placements

Figure 3. Layout - top layer

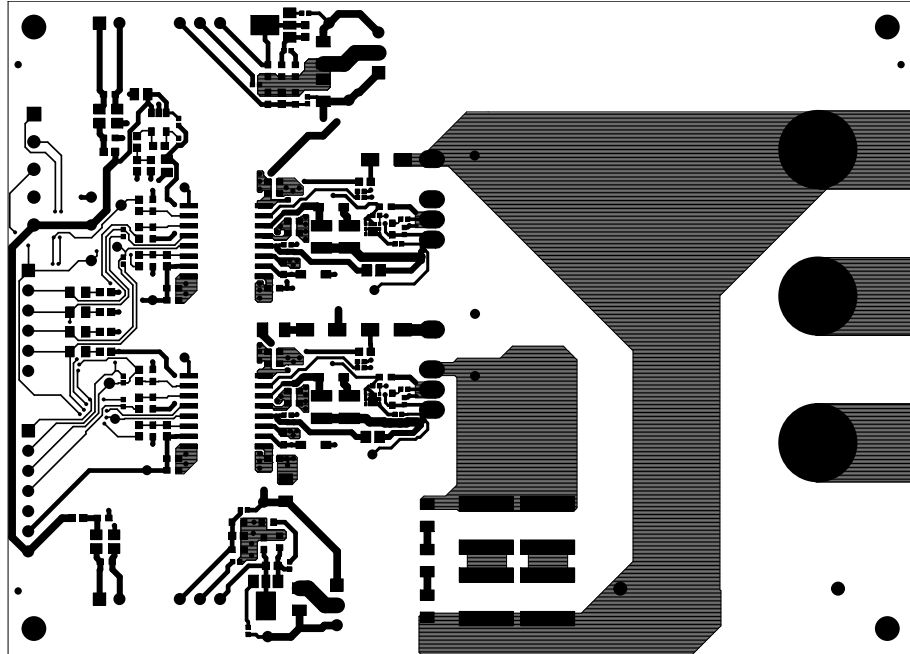

Figure 4. Layout - bottom layer

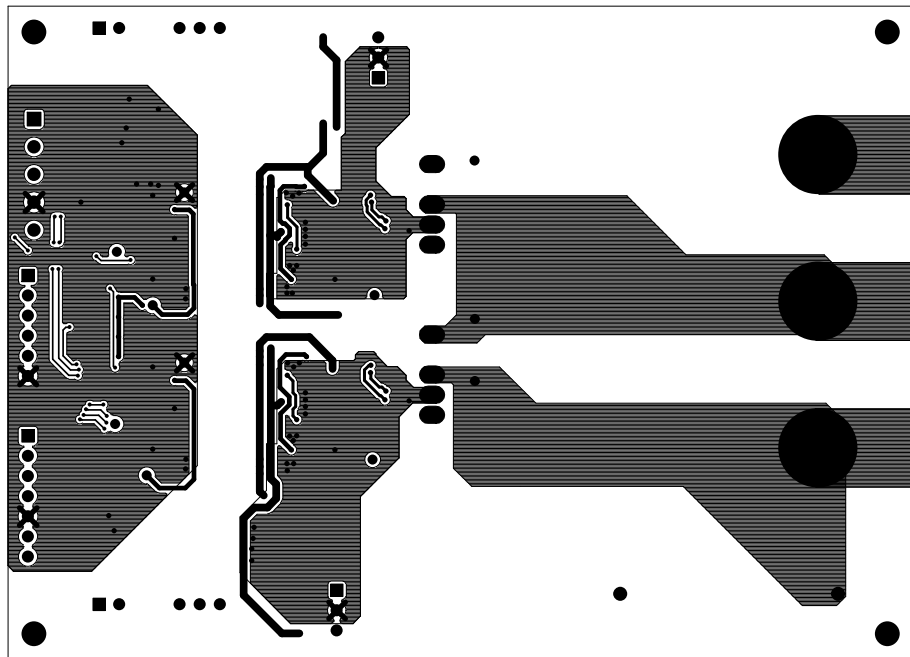
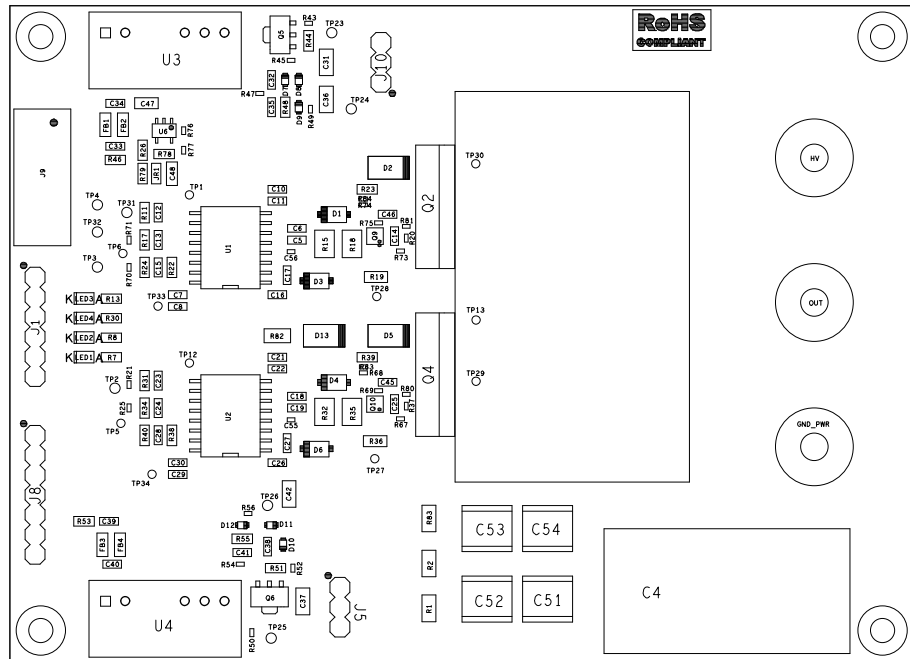

Figure 5. Layout - components placement top view



Revision history

Table 2. Document revision history

Date	Version	Changes
25-Oct-2024	1	Initial release.

Contents

1	Safety and operating instructions	3
1.1	General terms	3
1.2	Intended use of evaluation board	3
1.3	Installing the evaluation board	3
1.4	Operating the evaluation board	4
2	Schematic diagrams	5
3	Bill of materials	7
4	Layout and component placements	10
	Revision history	12
	List of tables	14
	List of figures	15



List of tables

Table 1.	EVLSTGAP3SXS-H bill of materials	7
Table 2.	Document revision history	12

List of figures

Figure 1.	EVLSTGAP3SXS-H schematic diagram - gate driver stage	5
Figure 2.	EVLSTGAP3SXS-H schematic diagram - power supplies.	6
Figure 3.	Layout - top layer	10
Figure 4.	Layout - bottom layer.	10
Figure 5.	Layout - components placement top view.	11

IMPORTANT NOTICE – READ CAREFULLY

STMicroelectronics NV and its subsidiaries (“ST”) reserve the right to make changes, corrections, enhancements, modifications, and improvements to ST products and/or to this document at any time without notice. Purchasers should obtain the latest relevant information on ST products before placing orders. ST products are sold pursuant to ST’s terms and conditions of sale in place at the time of order acknowledgment.

Purchasers are solely responsible for the choice, selection, and use of ST products and ST assumes no liability for application assistance or the design of purchasers’ products.

No license, express or implied, to any intellectual property right is granted by ST herein.

Resale of ST products with provisions different from the information set forth herein shall void any warranty granted by ST for such product.

ST and the ST logo are trademarks of ST. For additional information about ST trademarks, refer to www.st.com/trademarks. All other product or service names are the property of their respective owners.

Information in this document supersedes and replaces information previously supplied in any prior versions of this document.

© 2024 STMicroelectronics – All rights reserved