

3300 W CCM boost PFC based on M5 MOSFET and L4985A



The picture shown is for illustration purpose only.
Actual product may vary depending on buyer's selection and availability.

Features

- Universal input voltage range: 90 to 265 Vac, 45 to 65 Hz
- Regulated output voltage: 415 Vdc
- Rated output power: up to 3300 W
- Total harmonic distortion (THD): <6% at full load and <10% down to 20% load
- Switching frequency: 65 kHz
- Efficiency peak: 97.8%
- Harmonics and compliance as per IEC61000 norms

Description

The **STEVAL-3KW3PFCCB** board is the practical implementation of a 3.3 kW PFC boost module which is the major front end building block for any mains fed power conversion system.

It may be an EV charger, telecom power supplies, air-conditioners, or general high-power SMPS applications.

It has a compact form-factor: 125 x 180 x 60 mm³ and is intended to deliver full power under forced convection cooling at the EU voltage range.

It may be run in the universal range as well but, the output power must be derated accordingly to limit the current drawn from the mains and temperature rise of the heatsink.

The electrical specifications have been derived keeping in mind standard applications.

This board allows the engineer to evaluate a wide range of power output options.

Anything from sub 1000 till about 3300 W may be evaluated using this board by replacing the power MOSFETs with suitable types and optimizing the gate drive resistors.

STW57N65M5 and **STW69N65M5** have both been tested to be very suitable for targeting the 3000 to 3300 W power levels with no other changes required in this board and consistent performance figures.

Product summary	
3300 W CCM boost PFC based on M5 MOSFET and L4985A	STEVAL-3KW3PFCCB
Continuous conduction mode (CCM) PFC controller with high voltage startup	L4985A
N-channel 650 V, 56 mOhm typ., 42 A MDmesh M5 Power MOSFET in a TO-247 package	STW57N65M5
Applications	Residential climate control and HVAC Air conditioner (window/wall/portable)

1 Schematic diagrams

Notice: These schematics are for illustration purpose only. Actual product may vary depending on buyer's selection and availability.

Figure 1. STEVAL-3KW3PFCCB circuit schematic

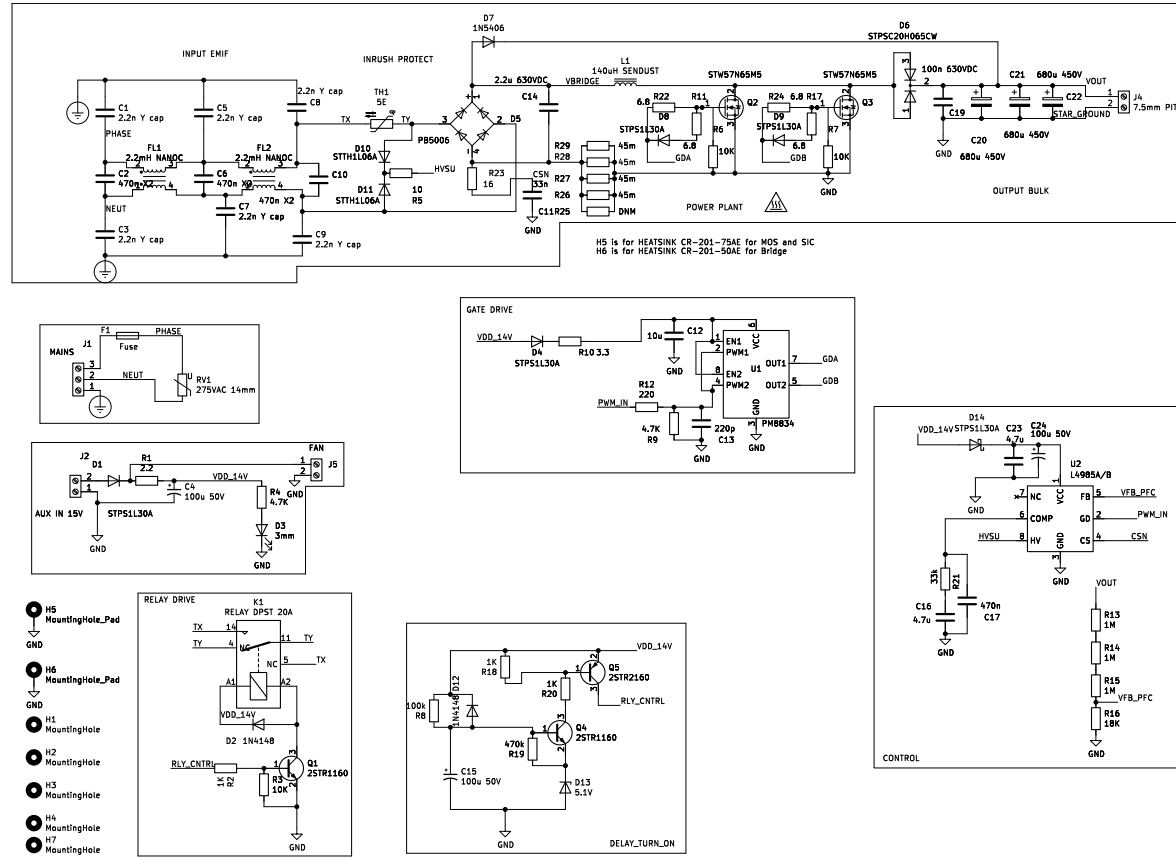



2 Custom evaluation boards information

Notice: These evaluation boards are custom designed and built, in small quantities, according to specific requests from customers and are destined for evaluation and testing of ST products in a research and development setting. Please contact ST to provide your specific requests and get your custom built board(s).

Revision history

Table 1. Document revision history

Date	Revision	Changes
05-Dec-2024	1	Initial release.

IMPORTANT NOTICE – READ CAREFULLY

STMicroelectronics NV and its subsidiaries (“ST”) reserve the right to make changes, corrections, enhancements, modifications, and improvements to ST products and/or to this document at any time without notice. Purchasers should obtain the latest relevant information on ST products before placing orders. ST products are sold pursuant to ST’s terms and conditions of sale in place at the time of order acknowledgment.

Purchasers are solely responsible for the choice, selection, and use of ST products and ST assumes no liability for application assistance or the design of purchasers’ products.

No license, express or implied, to any intellectual property right is granted by ST herein.

Resale of ST products with provisions different from the information set forth herein shall void any warranty granted by ST for such product.

ST and the ST logo are trademarks of ST. For additional information about ST trademarks, refer to www.st.com/trademarks. All other product or service names are the property of their respective owners.

Information in this document supersedes and replaces information previously supplied in any prior versions of this document.

© 2024 STMicroelectronics – All rights reserved