

IO-Link device with 8 digital output channels based on L6364



The picture shown is for illustration purpose only.
Actual product may vary depending on buyer's selection and availability.

Features

- Standard M12-A 5 Pin Male connector can be configured as IO-Link Class-B interface or Class-A interface (need external power supply)
- IO-Link communication supported by [L6364](#) and software stack inside [STM32G071CB](#)
- Input DC voltage range: 19-32V (IO-Link VBus)
- Isolated 8 digital output channels support by [ISO8200AQ](#)
- Standard M12-A 4 Pin Female Connectors used for each digital output channel
- Each connector provides VBus, output channel pin and ground pin, which supports both 2-wire or 3-wire actuator
- ESD protection provided by [SMBJ30CA](#)
- Reset button
- SWD connector for debugging and programming capability
- UART connector for debugging and serial data transmission
- Protections against surge pulse (up to $\pm 3\text{APK}$ with $500\ \Omega$ coupling) and reverse polarity
- RoHS compliant

Product summary

IO-Link device with 8 digital output channels based on L6364Q	STEVAL-IOL8DOCB
Applications	Factory automation

Description

The [STEVAL-IOL8DOCB](#) is an IO-Link device that features 8 digital channels. This device is designed to provide a turnkey solution for industrialization, making it an ideal choice for industrial applications and an easy way to evaluate all chips.

With its IO-Link communication (supported by [L6364](#) and software stack inside [STM32G071CB](#)) and standard M12-A 5 pin Male connector meeting IO-Link Class-B interface specifications, or IO-Link class-a interface if using the external power supply connector, the [STEVAL-IOL8DOCB](#) allows for easy integration with existing industrial IO-Link systems. Additionally, the input voltage range of 19-32 V (IO-Link VBUS) ensures reliable and stable performance in various industrial environments.

The isolated 8 digital output channels supported by [ISO8200AQ](#) and standard M12-A 4 pin female connectors for each channel make the [STEVAL-IOL8DOCB](#) a reliable and practical solution for digital output applications. Each connector provides VBUS, output channel pin, and ground pin, supporting both 2-wire or 3-wire high-side actuator.

Furthermore, the [STEVAL-IOL8DOCB](#) has considered ESD protection provided [SMBJ30CA](#), ensuring the safety and longevity of the device.

Overall, the [STEVAL-IOL8DOCB](#) is a reliable and efficient IO-Link device that offers isolated output channels and easy integration with existing industrial systems, helping industrial module makers evaluate all chips easier and speed up their prototype development.

1 Block diagram

Figure 1. Block diagram

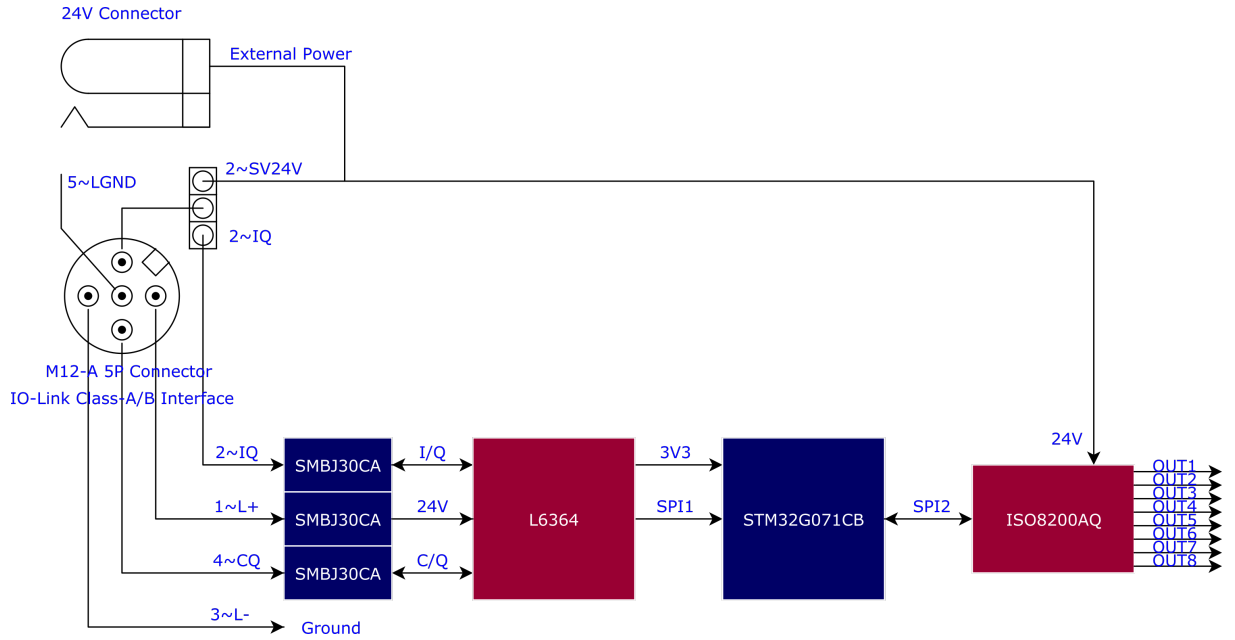

2 Schematic diagrams

Notice: These schematics are for illustration purpose only. Actual product may vary depending on buyer's selection and availability.

Figure 2. STEVAL-IOL8DOCB circuit schematic (1 of 4)

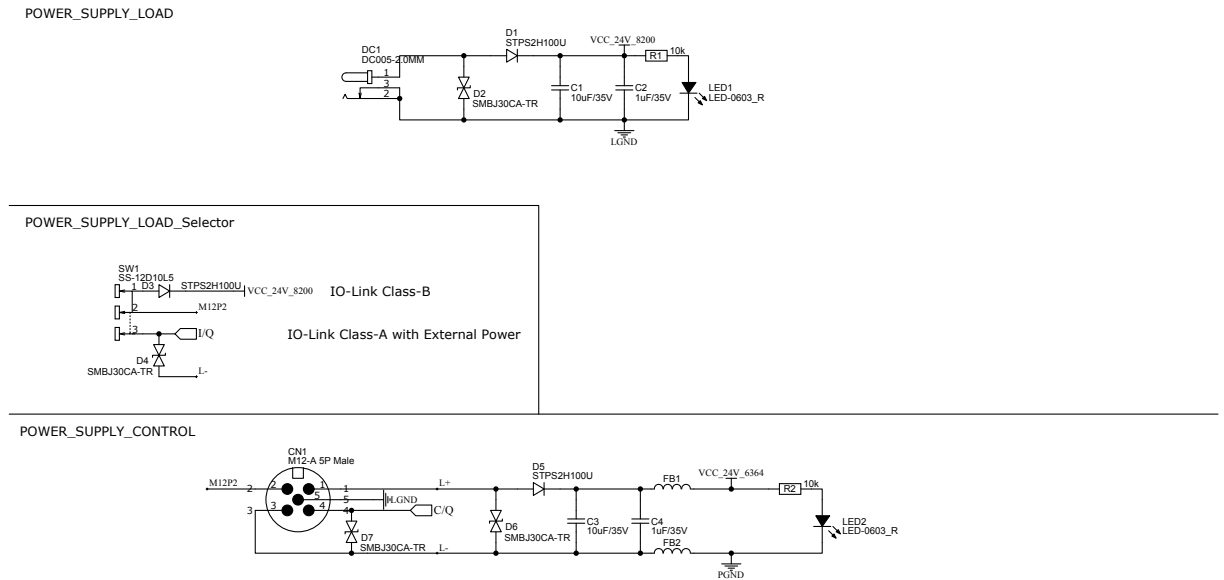

Figure 3. STEVAL-IOL8DOCB circuit schematic (2 of 4)

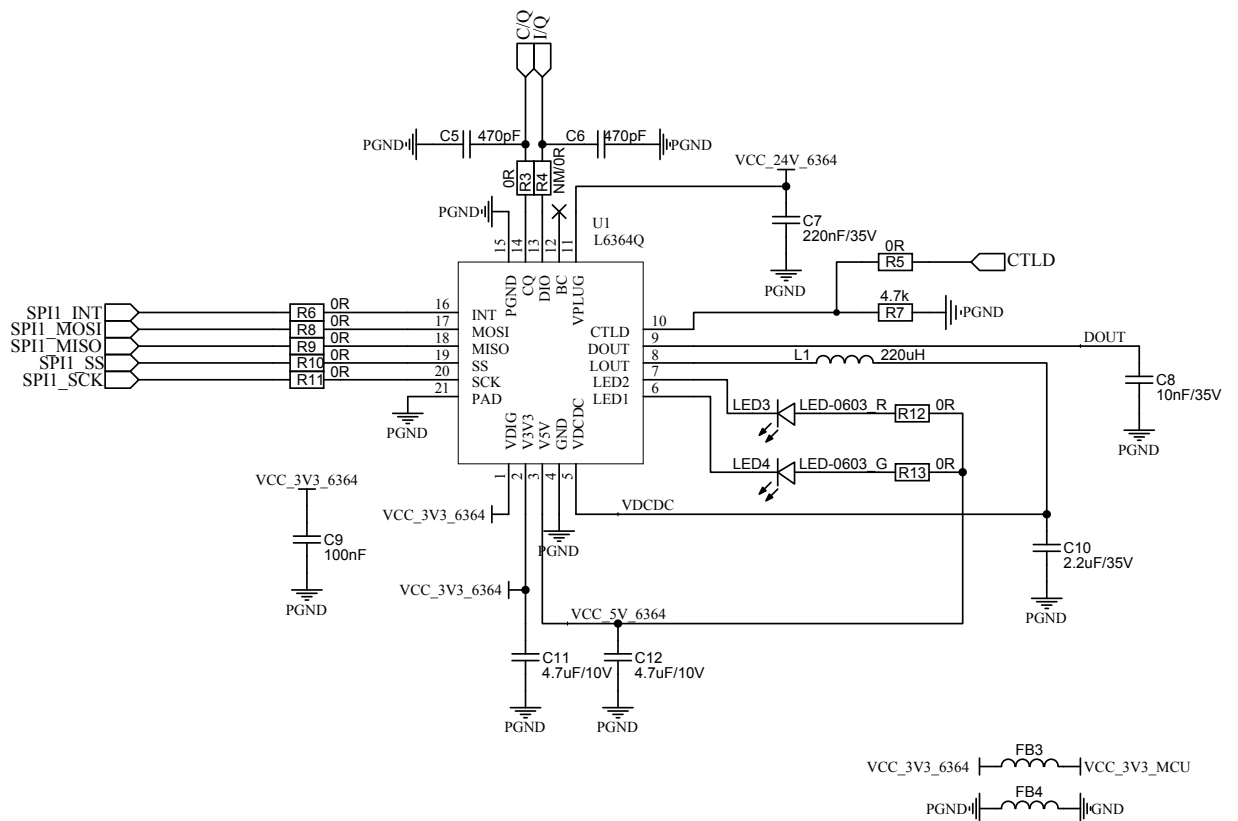

Figure 4. STEVAL-IOL8DOCB circuit schematic (3 of 4)

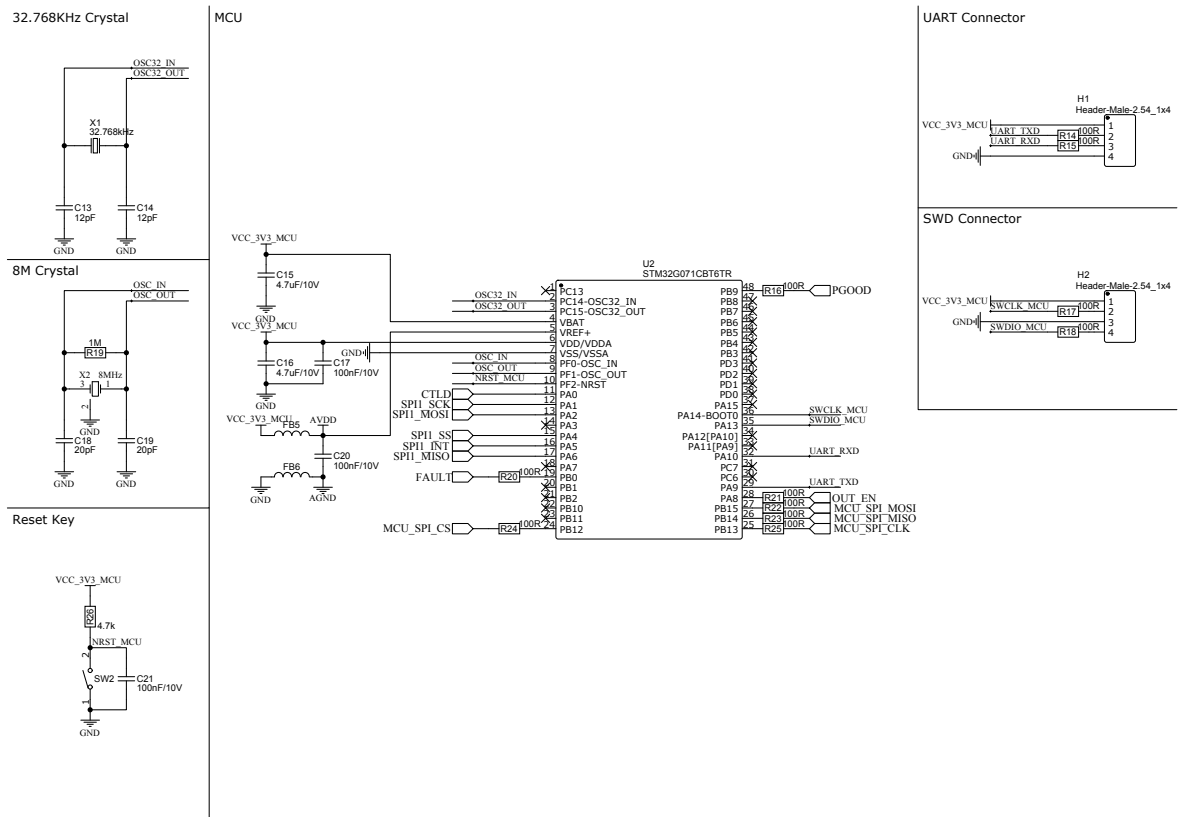
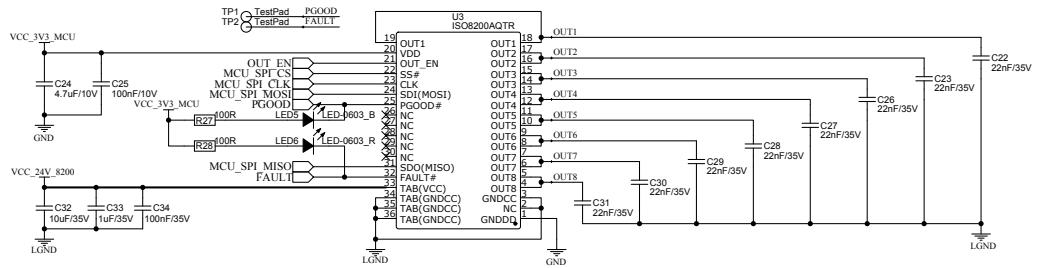
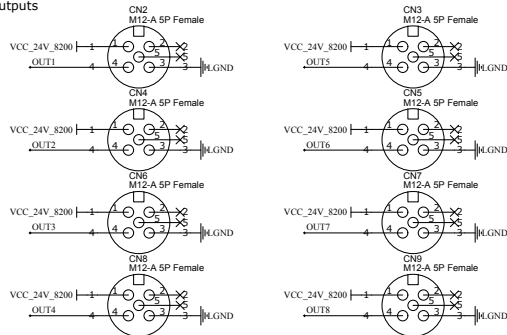

Figure 5. STEVAL-IOL8DOCB circuit schematic (4 of 4)

ISO8200AQ



Outputs



Output Indicator

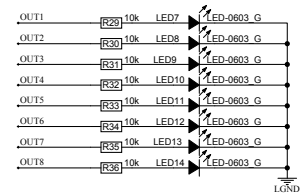

3 Custom evaluation boards information

Notice: These evaluation boards are custom designed and built, in small quantities, according to specific requests from customers and are destined for evaluation and testing of ST products in a research and development setting. Please contact ST to provide your specific requests and get your custom built board(s).

Revision history

Table 1. Document revision history

Date	Revision	Changes
06-May-2024	1	Initial release.

IMPORTANT NOTICE – READ CAREFULLY

STMicroelectronics NV and its subsidiaries (“ST”) reserve the right to make changes, corrections, enhancements, modifications, and improvements to ST products and/or to this document at any time without notice. Purchasers should obtain the latest relevant information on ST products before placing orders. ST products are sold pursuant to ST’s terms and conditions of sale in place at the time of order acknowledgment.

Purchasers are solely responsible for the choice, selection, and use of ST products and ST assumes no liability for application assistance or the design of purchasers’ products.

No license, express or implied, to any intellectual property right is granted by ST herein.

Resale of ST products with provisions different from the information set forth herein shall void any warranty granted by ST for such product.

ST and the ST logo are trademarks of ST. For additional information about ST trademarks, refer to www.st.com/trademarks. All other product or service names are the property of their respective owners.

Information in this document supersedes and replaces information previously supplied in any prior versions of this document.

© 2024 STMicroelectronics – All rights reserved