

Laser pico projection specific image-processor

Data brief –preliminary data

Features

- Supports TTL/CMOS video input
 - 24-bit RGB/YUV raster video input up to 80 MHz pixel clock
 - ITU-R BT.656 input
- Supports MIPI DSI video input
 - Up to four lanes, up to 800 Mb/s per lane
- Supports video formats up to 720p (1280 x 720) in 16/9 format or XGA (1024 x 768) in 4/3 format
- Integrated video processor
 - Image scaler
 - Color space conversion
 - Image color adjustment
 - Geometrical compensation
- ARM® Cortex™ M3 integrated MCU
- 100% brightness uniformity support
- Integrated mirror control
- Integrated laser driver interface
- Hardware laser safety mechanism
- Specific interface for Opto Electronic Integrated Circuits (OEIC)
- Dual DACs for vertical ST MEMS (Micro-electro mechanical systems) mirror control
- Four input ADC used for mirror control
- Peripherals: UART, JTAG, SPI, GPIO, I2C master, I2C slave
- Low power operation
 - Less than 375 mW @ 720p
- Low power MIPI sleep mode
- Package: TFBGA (8 x 8 mm, 242 balls, 0.4 mm pitch)

Applications

Consumer applications: Phones, tablets, PMP integrating HD or non-HD laser based pico projector, standalone HD laser pico-projector, digital camera (still and video), user interfaces

Automotive applications: Cars head up display, navigation systems, and instrumentation displays

Professional applications: Video conferencing systems, medical, emergency interfaces.

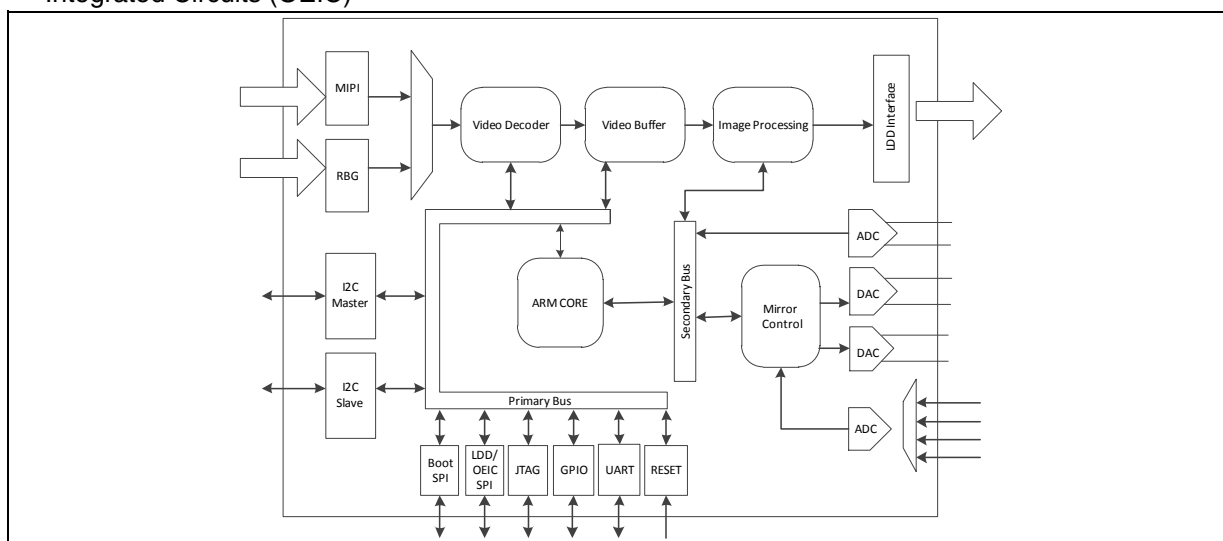

1 Description

The STPP0100 and STPP0101 chips are innovative, integrated video processor and application controllers designed for laser pico-projection systems and HD laser pico-projection systems. They support video inputs of up to XGA (1024 x 768) in 4/3 format or 720p HD (1280 x 720) in 16/9 format.

The STPP0100 and STPP0101 ICs support a MIPI DSI video interface. They allow seamless integration into mobile equipment such as phones, tablets, digital still camera or video camera, gaming consoles, and MP3 players amongst others. The MIPI DSI interface supports DPI mode, four lanes 800 Mb/sec bit rate to support up to 720p video or picture resolution. It also supports TTL/CMOS input for standalone pico-projector type applications.

The STPP0100 and STPP0101 chip series takes a video input stream, renders it to modulate the lasers with the correct color/timing, outputs the results on a laser diode driver interface, and generates the ST MEMS mirror driver commands.

2 Benefits

The STPP0100 and STPP0101 ICs include a feature called dynamic white balance to compensate for temperature induced color shift in the tri-laser projector. These SoCs enable the HD pico-projection to have close to 100% brightness uniformity.

Also, available is an integrated set of communication interfaces to interconnect with the rest of the application. The communication interfaces count as 1x SPI bootable, I2C (1 slave and 1 master), UART, and GPIO. In addition to the communication interfaces, STPP0100 and STPP0101 includes a selectable quad input 10-bit ADC for additional control of the application.

Other benefits include:

- Seamless integration in mobile devices
- Fully dedicated and integrated SoC
- Integrated eye safety mechanism
- HD video input support
- Arm Cortex M3
- Low power in mission mode (<375 mW typical for 720p)
- Low power MIPI standby mode (<650 μ W)

3 Main features

- Resolution 4/3 up to XGA, 16/9 up to 720p @ 60 FPS. Any lower resolution is supported natively—no scaling is required
- Video input support
 - up to XGA 60 Hz max in 4/3 format
 - up to 720p 60 Hz max in 16/9 format
 - 24 bit RGB/YUV raster scan video up to 80 MHz pixel clock
 - MIPI DSI
 - ITU-R BT656
- MIPI DSI/DPI and parallel video input supporting ITU-R BT.656 with configurable color depth up to 24 bits
- Supporting MEMS mirrors
- Integrated mirror/lasers Analog Front End (AFE)
- Integrated ARM Cortex-M3 microcontroller and peripherals for autonomous operation
- Package TFBGA- 8 x 8 mm, 242 balls, 0.4 mm pitch
- Low power (375 mW typical for 720p)
- Deep sleep (no data retention) (<650 μ W)

3.1 ARM Cortex-M3 microcontroller subsystem

- ARM Cortex-M3 standard core with bootstrap ROM
- Software loaded from external SEEP or application processor by high speed SPI
- IIC / SPI control interface
- GPIO user interface

3.2 Video pre-processing

- Color space/video format conversion
- Color inversion/complementary color transform

3.3 Laser modulation

- Geometrical interpolation engine supporting MEMS mirrors ensures full cancellation of any barrel or pin cushion distortion effects
- Digital keystone correction
- Configurable brightness uniformity compensation, up to 100% uniformity
- Color temperature (white balance) control
- Laser linearity compensation
- Brightness/contrast and gamma corrections

3.4 MEMS mirror interface

- Supporting MEMS resonance mode horizontal mirror, and linear mode vertical mirror
- Mirror control interface including:
 - Dual channel DAC with differential output
 - Quad input DAC for mirror control feedback
- Vertical mirror drive LUT
- Horizontal mirror pulse generator

3.5 Laser interface

- Support of RGB direct laser diodes
- Lasers are controlled by software running on ARM MCU
- Integrated AFE with differential input to interface with external optical power detector

3.6 Eye safety monitor

- Built-in mirror movement monitoring
- External proximity detection support
- System watchdog monitor

3.7 Additional digital interfaces

- Multiple configurations supported
- Dedicated laser driver interface up to 150 MHz
- 2 x I²C
- SPI + 1 proprietary SPI
- UART
- GPIO (8 bits)
- JTAG

4 Application overview

Figure 1. STPP0100 and STPP0101 application overview

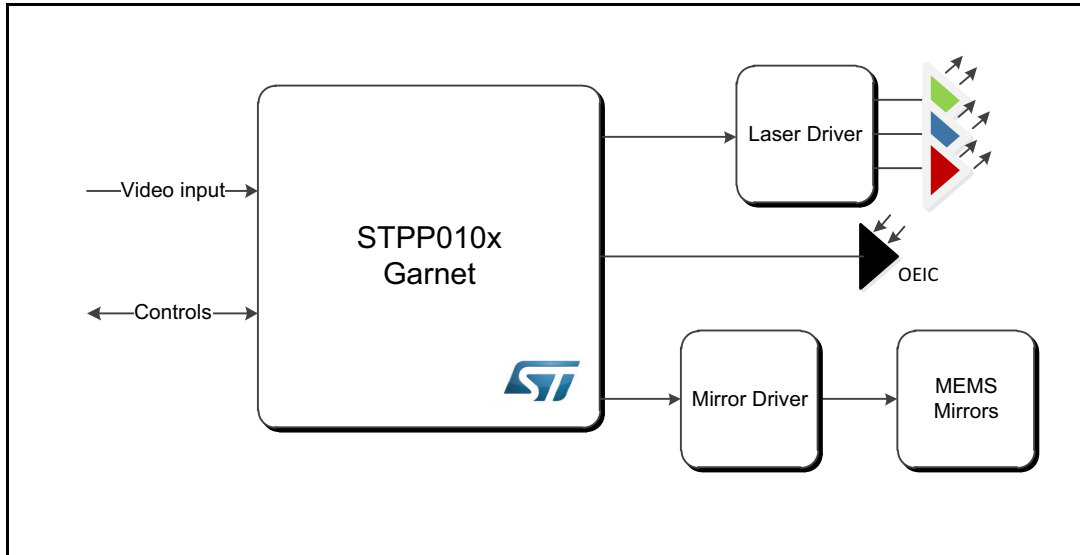

5 Ordering information

Table 1. Order codes

Part number	Description
STPP0101-AA (Generic)	TFBGA 8 x 8 mm
STPP0100-AA (Reserved)	TFBGA 8 x 8 mm

5.1 ECOPACK®

In order to meet environmental requirements, ST offers these devices in different grades of ECOPACK® packages, depending on their level of environmental compliance. ECOPACK® specifications, grade definitions and product status are available at: www.st.com. ECOPACK® is an ST trademark.

6 Revision history

Table 2. Document revision history

Date	Revision	Changes
21-Nov-2012	1	Initial release.

Please Read Carefully:

Information in this document is provided solely in connection with ST products. STMicroelectronics NV and its subsidiaries ("ST") reserve the right to make changes, corrections, modifications or improvements, to this document, and the products and services described herein at any time, without notice.

All ST products are sold pursuant to ST's terms and conditions of sale.

Purchasers are solely responsible for the choice, selection and use of the ST products and services described herein, and ST assumes no liability whatsoever relating to the choice, selection or use of the ST products and services described herein.

No license, express or implied, by estoppel or otherwise, to any intellectual property rights is granted under this document. If any part of this document refers to any third party products or services it shall not be deemed a license grant by ST for the use of such third party products or services, or any intellectual property contained therein or considered as a warranty covering the use in any manner whatsoever of such third party products or services or any intellectual property contained therein.

UNLESS OTHERWISE SET FORTH IN ST'S TERMS AND CONDITIONS OF SALE ST DISCLAIMS ANY EXPRESS OR IMPLIED WARRANTY WITH RESPECT TO THE USE AND/OR SALE OF ST PRODUCTS INCLUDING WITHOUT LIMITATION IMPLIED WARRANTIES OF MERCHANTABILITY, FITNESS FOR A PARTICULAR PURPOSE (AND THEIR EQUIVALENTS UNDER THE LAWS OF ANY JURISDICTION), OR INFRINGEMENT OF ANY PATENT, COPYRIGHT OR OTHER INTELLECTUAL PROPERTY RIGHT.

UNLESS EXPRESSLY APPROVED IN WRITING BY TWO AUTHORIZED ST REPRESENTATIVES, ST PRODUCTS ARE NOT RECOMMENDED, AUTHORIZED OR WARRANTED FOR USE IN MILITARY, AIR CRAFT, SPACE, LIFE SAVING, OR LIFE SUSTAINING APPLICATIONS, NOR IN PRODUCTS OR SYSTEMS WHERE FAILURE OR MALFUNCTION MAY RESULT IN PERSONAL INJURY, DEATH, OR SEVERE PROPERTY OR ENVIRONMENTAL DAMAGE. ST PRODUCTS WHICH ARE NOT SPECIFIED AS "AUTOMOTIVE GRADE" MAY ONLY BE USED IN AUTOMOTIVE APPLICATIONS AT USER'S OWN RISK.

Resale of ST products with provisions different from the statements and/or technical features set forth in this document shall immediately void any warranty granted by ST for the ST product or service described herein and shall not create or extend in any manner whatsoever, any liability of ST.

ST and the ST logo are trademarks or registered trademarks of ST in various countries.

Information in this document supersedes and replaces all information previously supplied.

The ST logo is a registered trademark of STMicroelectronics. All other names are the property of their respective owners.

© 2012 STMicroelectronics - All rights reserved

STMicroelectronics group of companies

Australia - Belgium - Brazil - Canada - China - Czech Republic - Finland - France - Germany - Hong Kong - India - Israel - Italy - Japan - Malaysia - Malta - Morocco - Philippines - Singapore - Spain - Sweden - Switzerland - United Kingdom - United States of America

www.st.com

