

LIV Evaluation Board revC

Schematics

SHEET NAME

PAGE 01 : Cover	REF DES: 100 - 199
PAGE 02 : Bloc diagram	REF DES: 200 - 299
PAGE 03 : LIV	REF DES: 300 - 399
PAGE 04 : Front end	REF DES: 400 - 499
PAGE 05 : Power & Miscelianous	REF DES: 500 - 599

THE INFORMATION CONTAINED IN THESE SCHEMATIC SHEETS IS PRELIMINARY AND SUBJECT TO CHANGE WITHOUT NOTICE. STMicroelectronics BEARS NO RESPONSABILITY FOR ANY ERRORS IN THESE SCHEMATIC SHEETS.

 life.augmented	Board Title	LIV EVB EVALUATION BOARD REVC LIV4F		CONFIDENTIAL AND PROPRIETARY INFORMATION This drawing and the information herein, is not to be used or copied without the prior written permission of STMicroelectronics.
	Sheet Title	PAGE 01: Cover		
Doc No	Date	Rev	Sheet	
	Thursday, March 24, 2022	C	1 / 5	

Bloc diagram

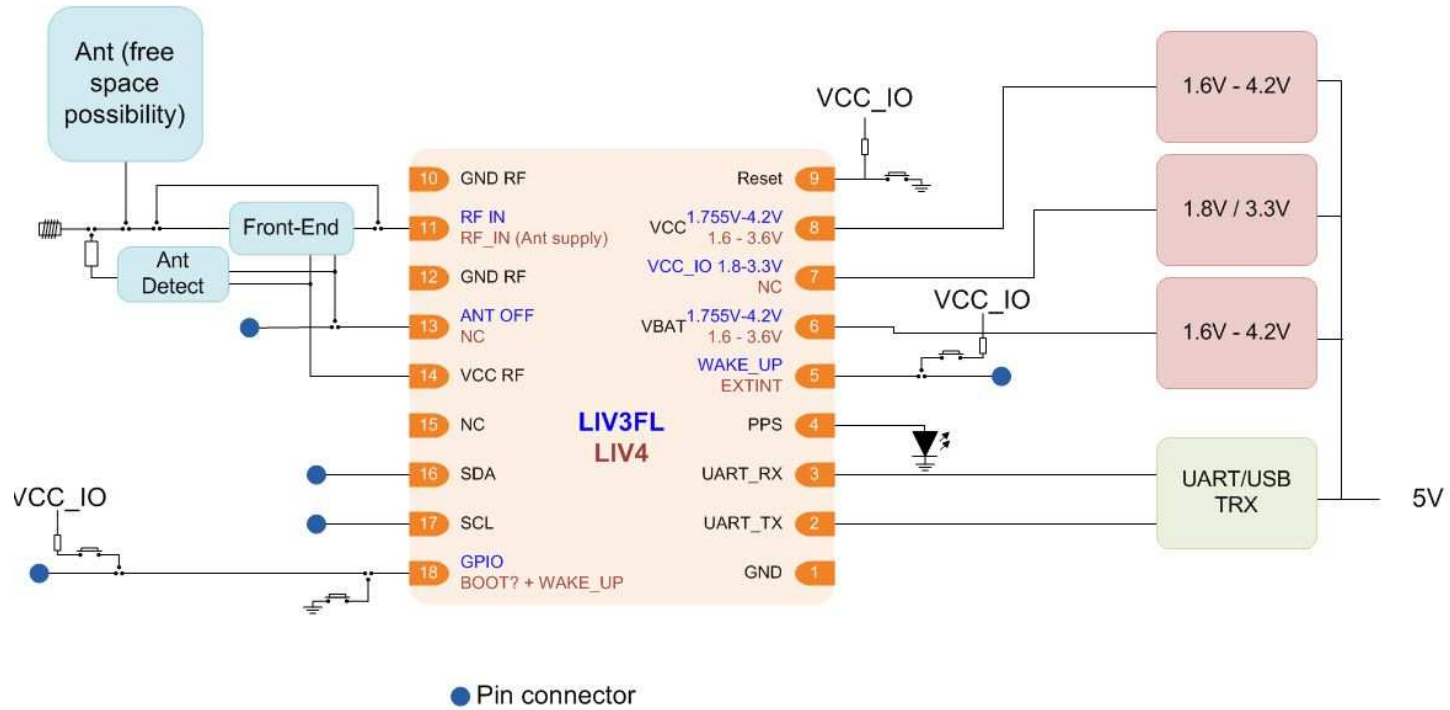

UART BY USB

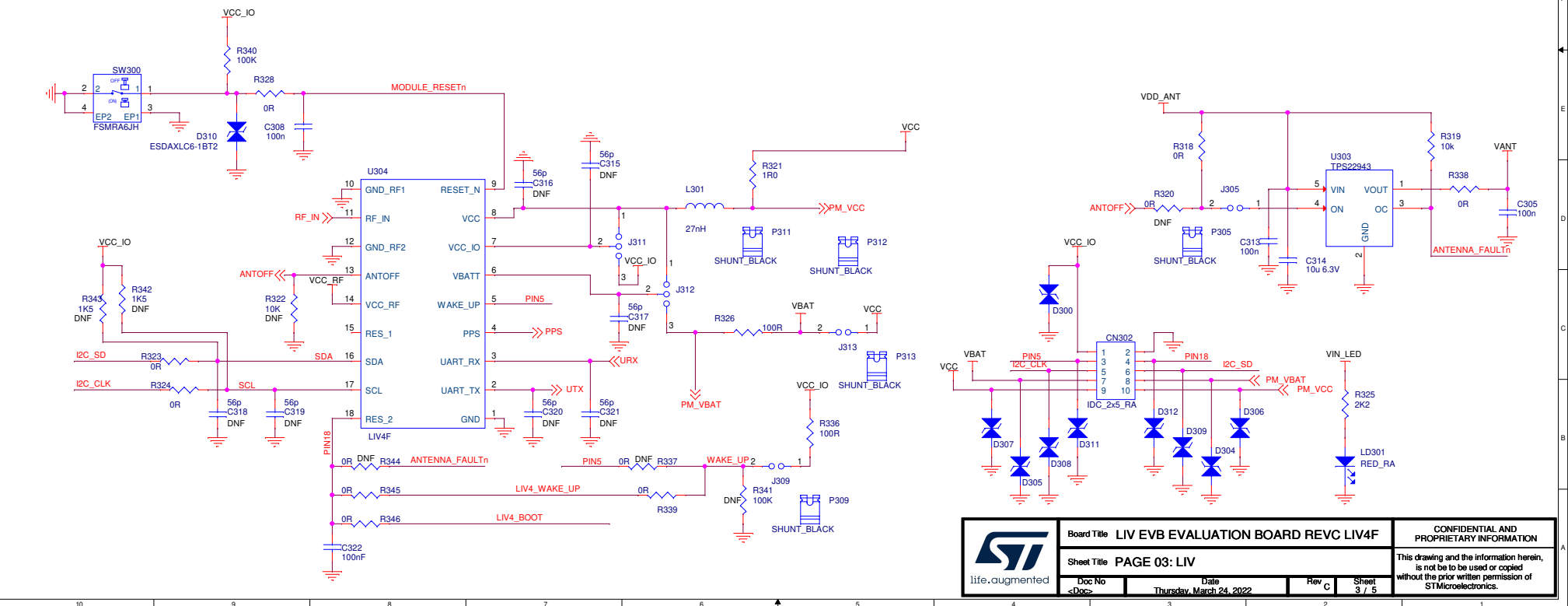
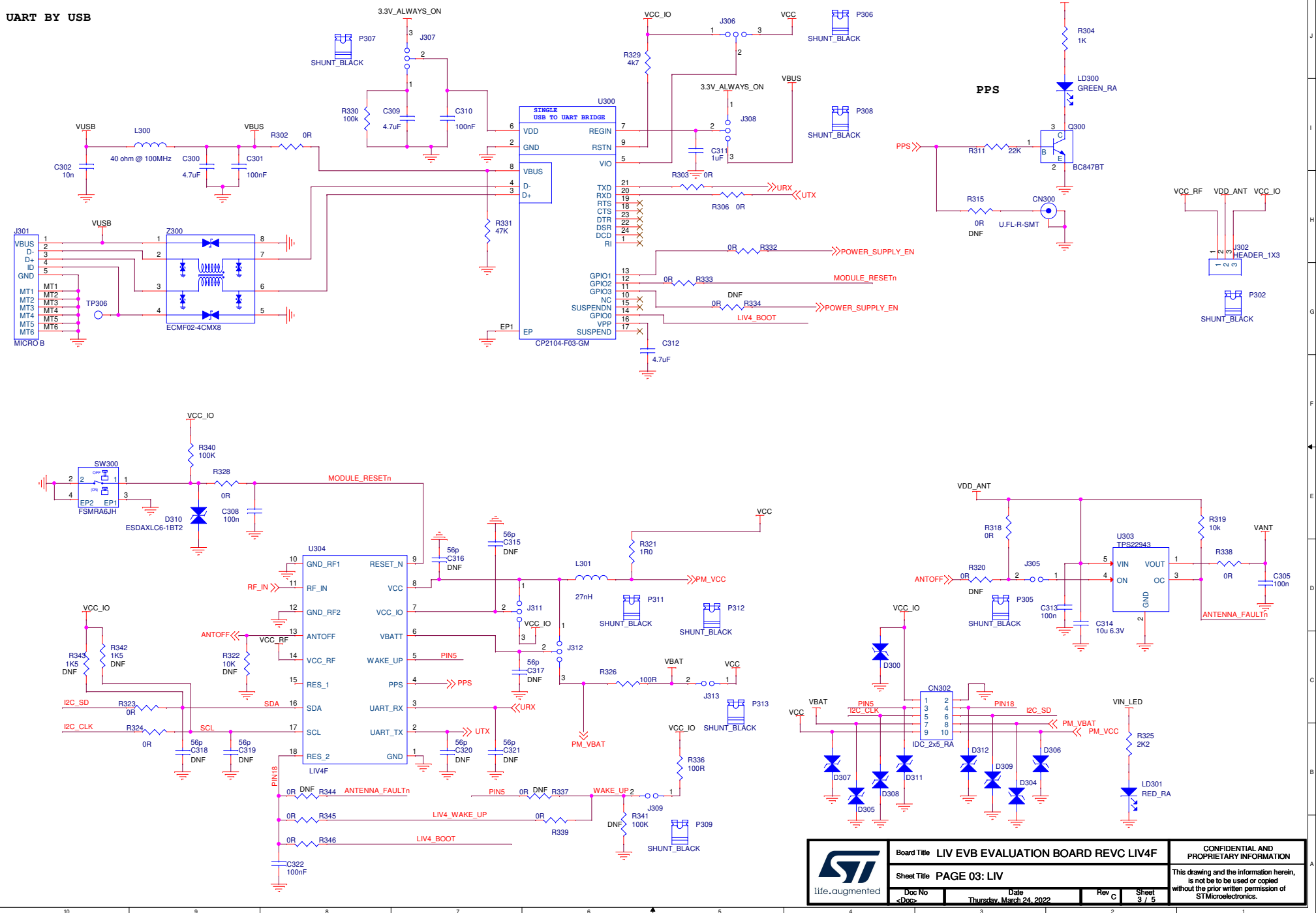

POWER

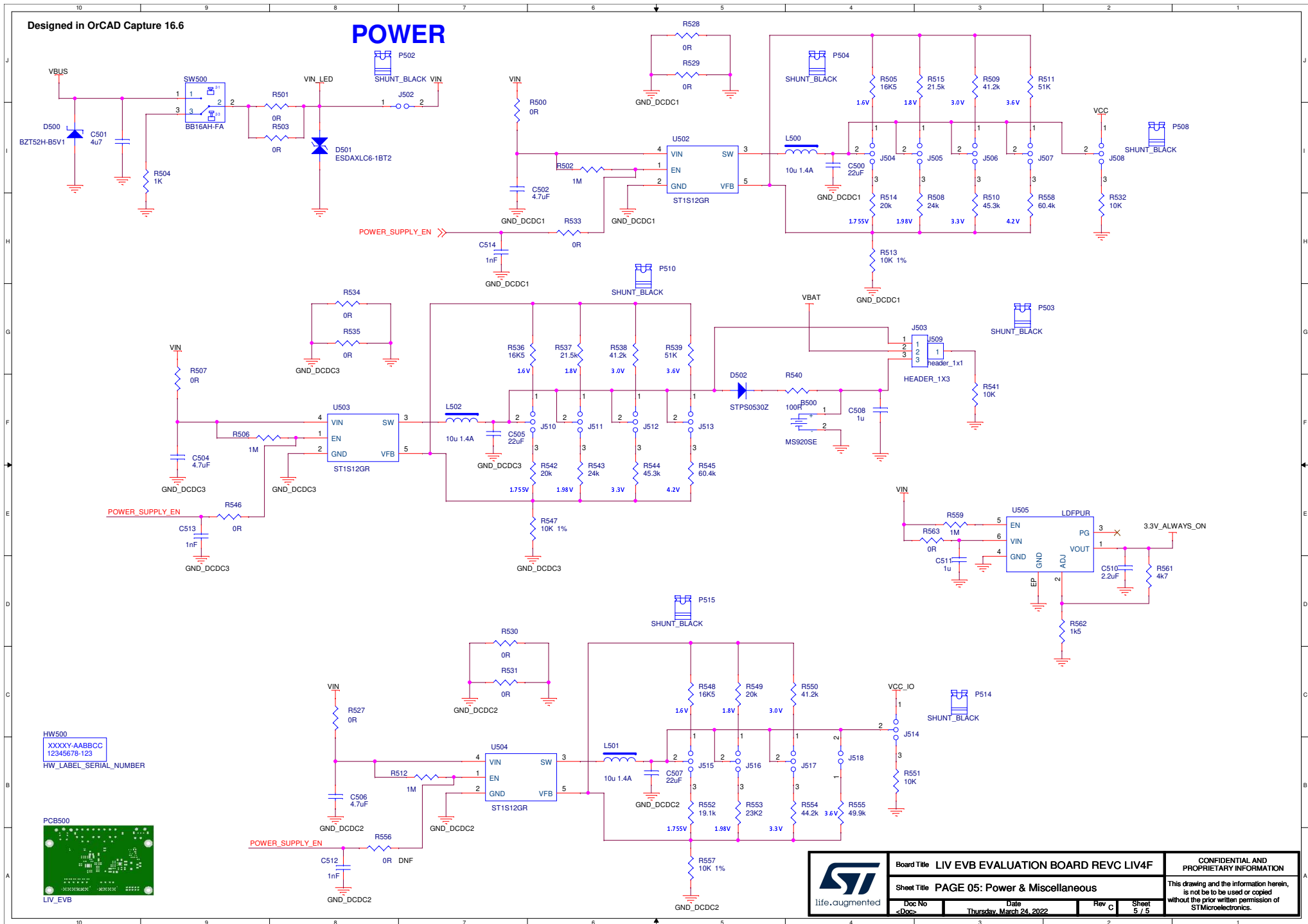

HW500
 XXXXY-AABBCC
 12345678-123
 HW_LABEL_SERIAL_NUMBER

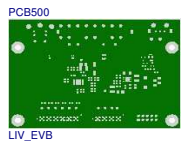

 life.augmented	Board Title	LIV EVB EVALUATION BOARD REV C LIV4F	CONFIDENTIAL AND PROPRIETARY INFORMATION	
	Sheet Title	PAGE 05: Power & Miscellaneous	This drawing and the information herein, is not to be used or copied without the prior written permission of STMicroelectronics.	
	Doc No	<Doc>	Date	Thursday, March 24, 2022
				Sheet 5 / 5