

Getting started with the NFC card reader expansion board based on ST25R100 for STM32 Nucleos

Introduction

The X-NUCLEO-NFC09A1 NFC card reader expansion board is based on the ST25R100 device.

The expansion board supports ISO14443A/B and ISO15693.

The ST25R100 manages frame coding and decoding in reader mode for standard applications, such as NFC, proximity, and vicinity HF RFID standards. It supports ISO/IEC 14443 type A/B and ISO/IEC 15693 RF communication protocols as well as the detection, reading and writing of NFC Forum type 1, 2, 4, and 5 tags.

It embeds a low power wake-up system capable of detecting an approaching tag. It also features a low power RC oscillator and wake-up timer to wake up the device automatically after a selected time period and check for a tag presence.

Figure 1. X-NUCLEO-NFC09A1 expansion board

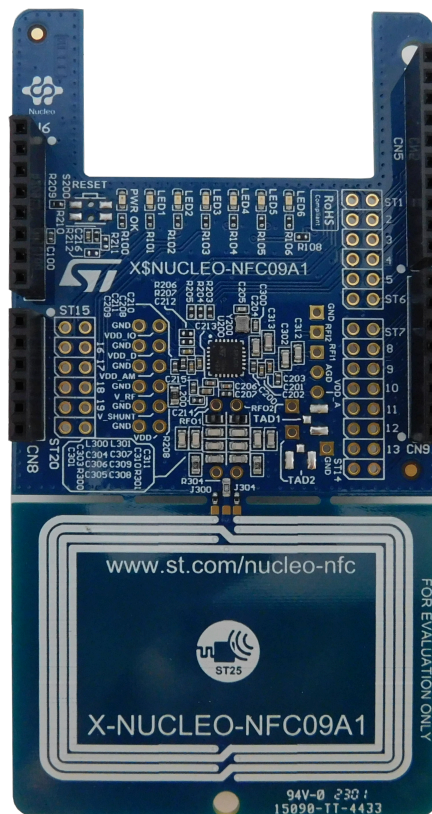

Notice: For dedicated assistance, please submit a request through our online support portal at www.st.com/support.

1 Getting started

1.1 Overview

The X-NUCLEO-NFC09A1 expansion board features:

- On-board NFC card reader IC: [ST25R100](#)
- 47 mm x 34 mm, four-turn 13.56 MHz inductive antenna etched on PCB with a maximum emitted RF magnetic field of 42 dB μ A/m @10 m, and associated tuning circuit
- RC low power wake-up
- Equipped with Arduino® UNO R3 connector
- Free comprehensive development firmware library compatible with [STM32Cube](#) and samples for [ST25R100](#)
- Scalable solution for multiple board cascade
- Six general-purpose LEDs
- CE, UKCA, FCC, ISED certified
- RoHS and WEEE compliant

1.2 Board connection

Connect the X-NUCLEO-NFC09A1 to an [STM32 Nucleo-64](#) development board via Arduino® UNO R3 connectors.

The PC USB port has to be capable of delivering at least 300 mA at 5 V supply.

A green LED indicates whether the 5 V supply is present, while the six status LEDs are controlled via MCU.

Provision for unpopulated jumpers enable alternative connections of all lines (except the SPI) to the STM32 MCU.

The board is connected to a power supply or a PC. It should be used on a clean and non-flammable surface.

1.3 Hardware requirements

The X-NUCLEO-NFC09A1 expansion board is designed to be used with any [STM32 Nucleo](#) board, although complete testing has been performed using the [NUCLEO-G071RB](#) hosting the [STM32G071RB](#) microcontroller.

The STM32 Nucleo firmware and the related documentation are available at <http://www.st.com/stm32nucleo>.

1.4 System requirements

To use [STM32 Nucleo](#) boards with the X-NUCLEO-NFC09A1 expansion board the following software and hardware are required:

- an STM32 Nucleo-64 development board
- a Windows® PC to install the firmware package
- a USB type A to Micro-B USB cable to connect the STM32 Nucleo board to the PC
- the unit must be supplied by a safety extra low voltage with falling characteristics (<5 V, <15 W), according to EN60950-1. This power supply has to be classified as ES1 (Electrical Source1), PS1 according to EN62368-1

To install the board firmware package (order code: [X-CUBE-NFC9](#)) the PC must have:

- 128 MB of RAM
- 40 MB of free hard disk space

The [X-CUBE-NFC9](#) firmware and the related documentation are available at www.st.com.

2 Board setup

To set up the board:

- Step 1.** Connect the [X-NUCLEO-NFC09A1](#) expansion board to the [STM32 Nucleo](#) board from the top through the [Arduino® UNO R3](#) connectors
- Step 2.** Power the [STM32 Nucleo](#) board using a Micro-B USB cable
- Step 3.** Program the firmware on the [STM32 Nucleo](#) board using the provided example
- Step 4.** Reset the MCU using the reset button available on the [STM32 Nucleo](#) board.
The evaluation kit is ready to be used.

3 Hardware

The X-NUCLEO-NFC09A1 expansion board allows the user to test the functionality of the ST25R100, which supports the reader/writer modes.

The ST25R100 IC module and the STM32 Nucleo board are connected through CN5, CN6, CN8 and CN9 connectors (see the tables below).

Table 1. Interconnections between the X-NUCLEO-NFC09A1 expansion board and the NUCLEO-G071RB board (left side)

Signal	Connector	Pin number	NUCLEO-G071RB	X-NUCLEO-NFC09A1
NC	CN6 Power	1	PD1	-
IOREF		2	IOREF	(NC)
RESET		3	NRST	-
3V3		4	3V3	3V3 (VDD_IO)
5V		5	5V	5V (VDD)
GND		6	GND	GND
GND		7	GND	GND
VIN		8	VIN	-
A0	CN8 Power	1	PA0	IRQ_MCU
A1		2	PA1	MCU_LED1
A2		3	PA4	MCU_LED2
A3		4	PB1	MCU_LED3

Table 2. Interconnections between the X-NUCLEO-NFC09A1 expansion board and the NUCLEO-G071RB board (right side)

Signal	Connector	Pin number	NUCLEO-G071RB	X-NUCLEO-NFC09A1
GND	CN5 Digital	7	GND	GND
D13		6	PA5	SCLK_MCU
D12		5	PA6	MISO_MCU
D11		4	PA7	MOSI_MCU
D10		3	PB0	/SS_MCU
D8		1	PA9	RESET
D7	CN9 Digital	8	PA8	MCU_LED4
D6		7	PB10	MCU_LED5
D5		6	PB4	MCU_LED6

3.1 Host interface and GPIO connection

The X-NUCLEO-NFC09A1 expansion board contains the ST25R100-CMET chip and is powered by the STM32 Nucleo board.

The ST25R100 is driven by the microcontroller via SPI interface.

The six LEDs indicate the detected RFID technology.

3.2 X-NUCLEO-NFC09A1 expansion board component placement

Figure 2. X-NUCLEO-NFC09A1 component placement

1. General purpose LEDs
2. ST25R100
3. Matching circuit
4. 47x34 mm four-turn antenna

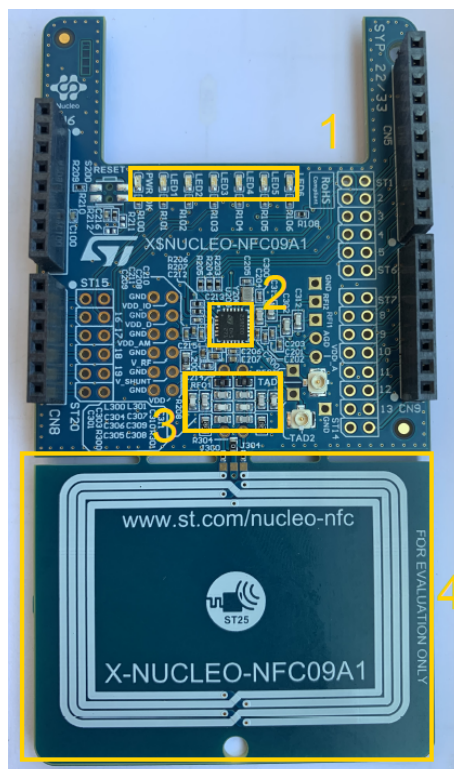

3.3 ST25R100 device

The **ST25R100** is a high performance NFC device that includes an advanced analog front end (AFE) and a highly integrated data framing system for:

- NFC-A/B (ISO 14443A/B) reader
- NFC-V (ISO 15693) reader up to 53 kbps

Special mode of the AFE and framing system can be used to implement other custom protocols such as MIFARE® classic.

4 Schematic diagrams

Figure 3. X-NUCLEO-NFC09A1 circuit schematic (1 of 3)

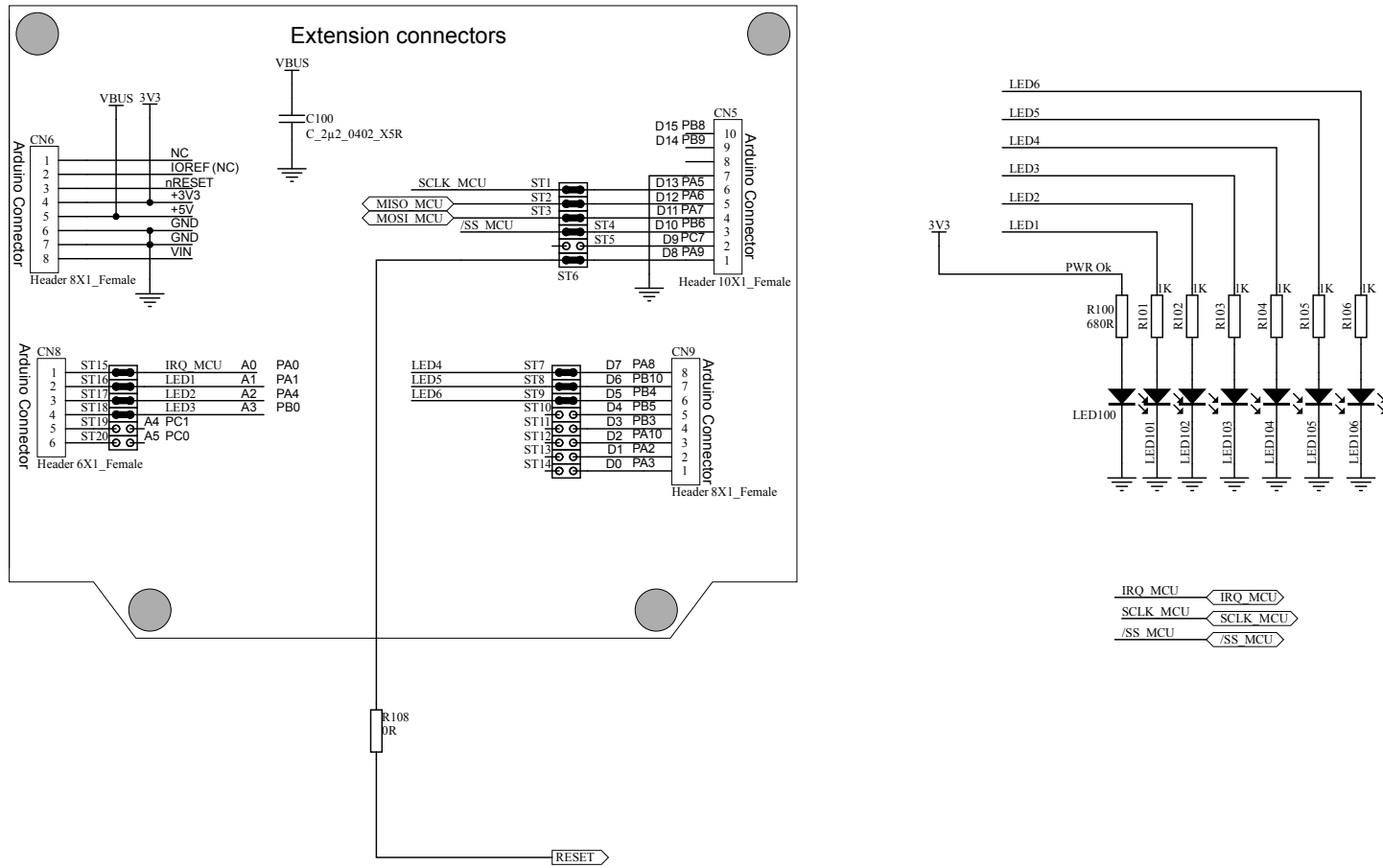

Figure 4. X-NUCLEO-NFC09A1 circuit schematic (2 of 3)

ST25R100 HF Reader

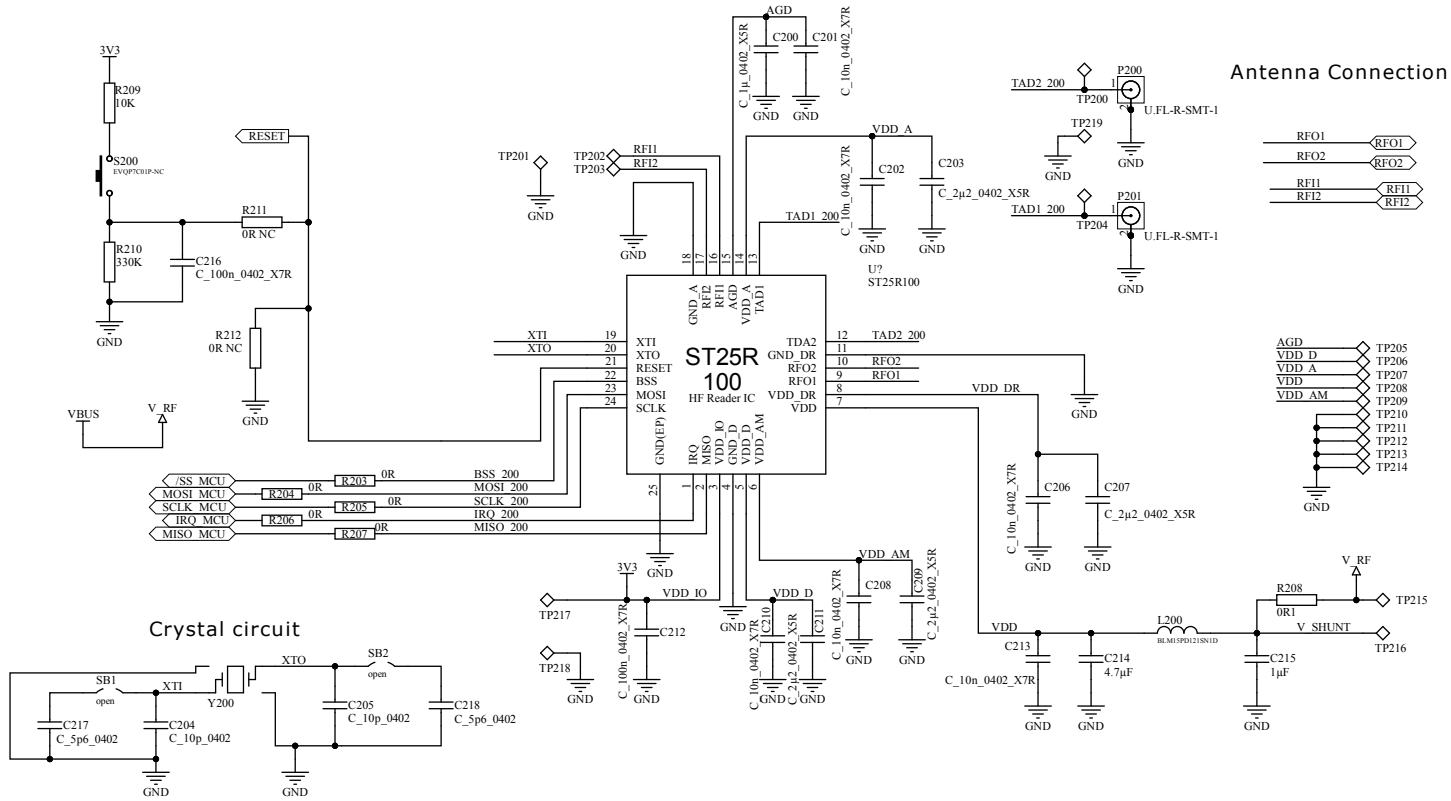
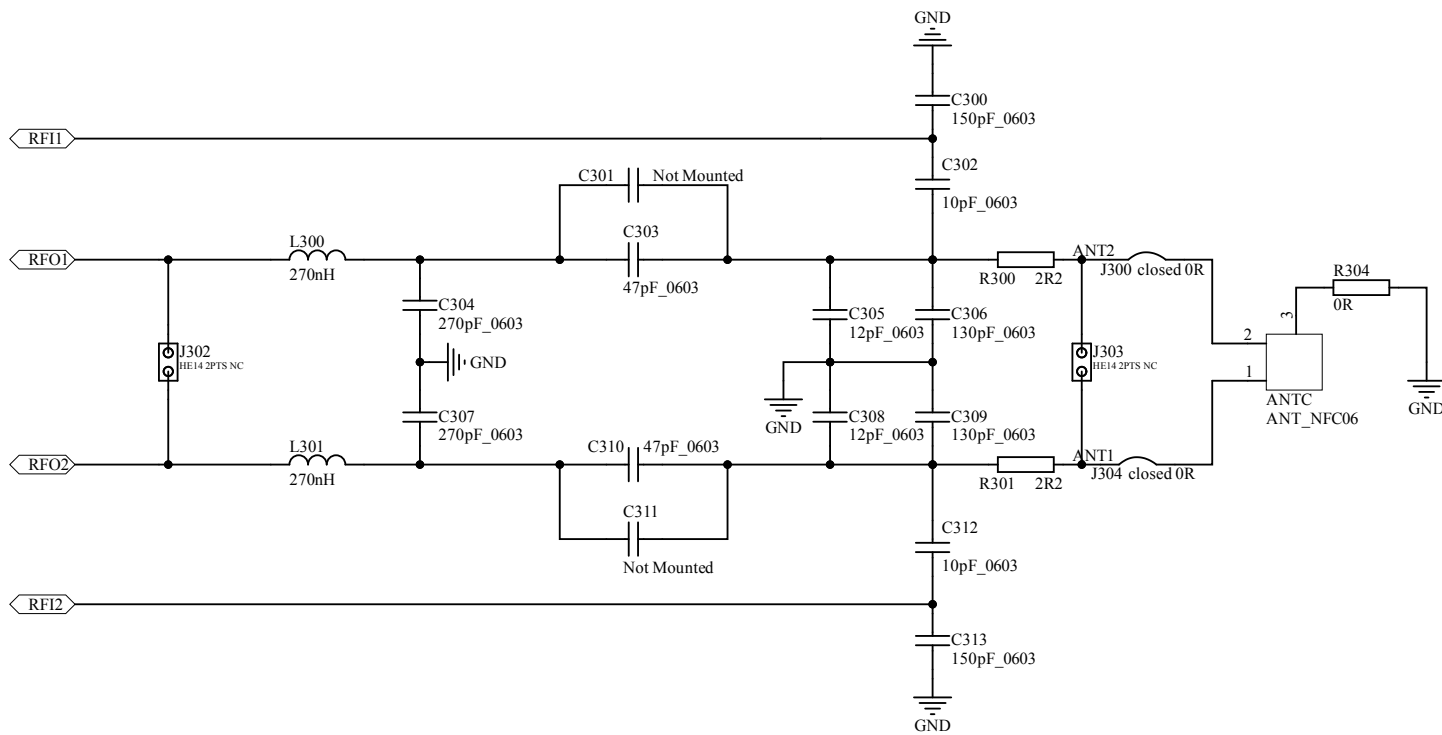

Figure 5. X-NUCLEO-NFC09A1 circuit schematic (3 of 3)

Antenna Circuit incl. EMI Filter and Matching



5 Bill of materials

Table 3. X-NUCLEO-NFC09A1 bill of materials

Item	Q.ty	Ref.	Part/Value	Description	Manufacturer	Order code
1	5	C100, C203, C207, C209, C211	2.2 uF 0402 6.3 V 20 %	Multilayer Ceramic Capacitors MLCC - SMD/SMT 2.2UF 6.3V 20% 0402	MURATA	GRM155R60J225ME15D
2	2	C200, C215	1.0 uF 0402 16 V 10 %	Multilayer Ceramic Capacitors MLCC - SMD/SMT 1.0UF 16V 10% 0402	MURATA	GRM155R61C105KA12D
3	6	C201, C202, C206, C208, C210, C213	0.01 uF 0402 25 V 10 %	Multilayer Ceramic Capacitors MLCC - SMD/SMT 25V 0.01uF X7R 0402 10%	AVX	04023C103KAT2A
4	2	C204, C205	10 p COG 0402 50 V 1 %	Multilayer Ceramic Capacitors MLCC - SMD/SMT 10 p 50 V COG 0402	MURATA	GRM1555C1H100GA01D
5	2	C212, C216	0.1 uF 0402 10 V 10 %	Multilayer Ceramic Capacitors MLCC - SMD/SMT 0.1 uF 10 V X5R 0402	MULTICOMP	MC0402X104K100CT
6	1	C214	4.7 uF 0402 10 V 20 %	Multilayer Ceramic Capacitors MLCC - SMD/SMT 4.7 uF 10 V X5R 0402	MURATA	GRM155R61A475MEAA
7	2	C217, C218	5.6 pF COG 0402 0.25 pF	Multilayer Ceramic Capacitors MLCC - SMD/SMT 5.6 PF 50V COG 0.25pF 0402	MURATA	GRM1555C1H5R6BA01D
8	2	C300, C313	150 pF 0603 50 V 2 %	Multilayer Ceramic Capacitors MLCC - SMD/SMT 150 pF 50 V COG 0402	MURATA	GRM1885C1H151GA01D

Item	Q.ty	Ref.	Part/Value	Description	Manufacturer	Order code
9	2	C301, C311	12 pF 0603 50 V 2 %	Multilayer Ceramic Capacitors MLCC - SMD/SMT 12 pF 50 V C0G 0603 (not mounted)	YAGEO	CQ0603GRNPO9BN120
10	2	C302, C312	10 pF 0603 50 V 1 %	CERAMIC CAPACITOR 10PF 50V, C0G, 1%, 0603,	MULTICOMP	MC0603N100F500CT
11	2	C303, C310	47 pF 0603 50 V 2 %	Multilayer Ceramic Capacitors MLCC - SMD/SMT 47PF 50V 1% 0603	MURATA	GCM1555C1H47FA16D
12	2	C304, C307	270 pF 0603 50 V 2 %	Multilayer Ceramic Capacitors MLCC - SMD/SMT 270 PF 50V C0G 2% 0603	MURATA	GCM1555C1H271FA01D
13	2	C305, C308	12 pF 0603 50 V 2 %	Multilayer Ceramic Capacitors MLCC - SMD/SMT 12 PF 50V NP0 2% 0603	MURATA	GRM1555C1H120GA01D
14	2	C306, C309	130 pF 0603 50 V 1 %	Multilayer Ceramic Capacitors MLCC - SMD/SMT 130 PF 50V NP0 1% 0603	MURATA	GCM1555C1H131FA16D
15	1	CN5		Header, 10-Pin, Single row,female	SAMTEC	SSQ-110-03-L-S
16	2	CN6, CN9		Header, 8-Pin, Single row,female	SAMTEC	SSQ-108-03-L-S
17	1	CN8		Header, 6-Pin, Single row,female	SAMTEC	SSQ-106-03-L-S
18	2	J300, J304	0 Ohm 0402 0.1 %	Thin Film Resistors 100mW ZEROohm Jumper	VISHAY	MCS04020Z0000ZE000
19	2	J302, J303		HE14 Male Vertical Single Row 2 pin 2.54MM (NOT MOUNTED)	MOLEX	22-28-5020
20	1	L200	120 Ohm 0402	Ferrite Beads 120 OHM 25%	MURATA	BLM15PD121SN1D

Item	Q.ty	Ref.	Part/Value	Description	Manufacturer	Order code
21	2	L300, L301	270 nH 0603 2 %	Fixed Inductors 0603 270nH Unshld 2% 300mOhms AEC-Q200	COILCRAFT	0603LS-271XGLB
22	1	LED100	0603 2V	Standard LEDs - SMD Green Clear 571nm	LITE-ON	LTST-C190KGKT
23	6	LED101, LED102, LED103, LED104, LED105, LED106	0603 2V	Standard LEDs - SMD Blue Clear 470nm	LITE-ON	LTST-C190TBKT
24	2	P200, P201		RF Connectors / Coaxial Connectors U.FL RECEPTACLE SMT GLD M CONT REEL (NOT MOUNTED)	HIROSE(HRS)	U.FL-R-SMT(10)
25	1	R100	680 Ohm 0402 5 %	Thick Film Resistors - SMD 680 Ohms 62.5mW 0402 5%	YAGEO	RC0402JR-07680RL
26	6	R101, R102, R103, R104, R105, R106	1K Ohm 0402 5 %	Thick Film Resistors - SMD 0402 1Kohms 5% AEC-Q200	PANASONIC	ERJ2GEJ102X
27	6	R108, R203, R204, R205, R206, R207	0 Ohm 0402 5 %	Thin Film Resistors 100mW ZERO ohm	VISHAY	MCS04020Z0000ZE000
28	1	R208	0.1 Ohm 0603 0.5 %	Current Sense Resistors - SMD 0.1 ohm 0603 0.5% 0.20W	OHMITE	KDV06DR100ET
29	1	R209	10k Ohm 0402 1%	Thick Film Resistors - SMD 10 kOhms 62.5 mW 0402 1% AEC-Q200	YAGEO	AC0402FR-7W10KL
30	1	R210	330k Ohm 0402 1 %	Thin Film Resistors - SMD .1W 330kohms .1% 0402 25ppm	VISHAY	CRCW0402330KFKEDC
31	2	R211, R212	0 Ohm 0402 0.1 %	Thin Film Resistors 100mW ZERO ohm (NOT MOUNTED)	VISHAY	MCS04020Z0000ZE000
32	2	R300, R301	2.2 Ohm 0603 1 %	Thick Film Resistors - SMD 2.2 Ohms 100 mW 0603 1% AEC-Q200	YAGEO	AC0603FR-072R2L

Item	Q.ty	Ref.	Part/Value	Description	Manufacturer	Order code
33	1	R304	0 Ohm 0603 1 %	Thick Film Resistors - SMD 0 Ohms 100mW 0603 1% AEC-Q200	YAGEO	AC0603FR-070RL
34	1	S200		Tactile Switches 3.5x2.9mm Right Ang Light Touch Switch (NOT MOUNTED)	PANASONIC	EVQ-P7C01P
35	11	ST1, ST2, ST3, ST4, ST7, ST8, ST9, ST15, ST16, ST17, ST18		CONN HE14 2PTS MALE VERTICAL (NOT MOUNTED)	TEST POINT	
36	6	ST5, ST10, ST11, ST12, ST13, ST14		CONN HE14 2PTS MALE VERTICAL (NOT MOUNTED)	TEST POINT	
37	1	ST6		CONN HE14 2PTS MALE VERTICAL (NOT MOUNTED)	TEST POINT	
38	2	ST19, ST20		CONN HE14 2PTS MALE VERTICAL (NOT MOUNTED)	TEST POINT	
39	1	U200		HF READER ST25R200 QFN24	ST	ST25R100
40	1	Y200		CRYSTAL 27.1200MHZ 10PF SMD	NDK AMERICA	NX2016SA-27.12MHZ- EXS00A-CS01188

6 Board versions

Table 4. X-NUCLEO-NFC09A1 versions

PCB version	Schematic diagrams	Bill of materials
X\$NUCLEO-NFC09A1 ⁽¹⁾	X\$NUCLEO-NFC09A1 schematic diagrams	X\$NUCLEO-NFC09A1 bill of materials

1. This code identifies the X-NUCLEO-NFC09A1 expansion board first version. It is printed on the board PCB.

7 Regulatory compliance information

Note: The evaluation kit with order code X-NUCLEO-NFC09A1 contains the board X\$NUCLEO-NFC09A1
 FCC certified, with FCC ID: YCPNFC09A1
 IC certified, with IC: 8976A-NFC09A1; PMN: X-NUCLEO-NFC09A1; HVIN: X-NUCLEO-NFC09A1

Notice for US Federal Communication Commission (FCC)

Part 15.19

This device complies with part 15 of the FCC Rules. Operation is subject to the following two conditions: (1) This device may not cause harmful interference, and (2) this device must accept any interference received, including interference that may cause undesired operation.

Part 15.21

Any changes or modifications to this equipment not expressly approved by STMicroelectronics may cause harmful interference and void the user's authority to operate this equipment.

Part 15.105

This equipment has been tested and found to comply with the limits for a Class B digital device, pursuant to part 15 of the FCC Rules. These limits are designed to provide reasonable protection against harmful interference in a residential installation. This equipment generates, uses and can radiate radio frequency energy and, if not installed and used in accordance with the instructions, may cause harmful interference to radio communications. However, there is no guarantee that interference will not occur in a particular installation. If this equipment does cause harmful interference to radio or television reception, which can be determined by turning the equipment off and on, the user is encouraged to try to correct the interference by one or more of the following measures:

- Reorient or relocate the receiving antenna.
- Increase the separation between the equipment and receiver.
- Connect the equipment into an outlet on a circuit different from that to which the receiver is connected.
- Consult the dealer or an experienced radio/TV technician for help

Notice for Innovation, Science and Economic Development Canada (ISED)

This device contains licence-exempt transmitter(s)/receiver(s) that comply with Innovation, Science and Economic Development Canada's licence exempt RSS(s). Operation is subject to the following two conditions: (1) This device may not cause interference. (2) This device must accept any interference, including interference that may cause undesired operation of the device. Changes or modifications not expressly approved by the party responsible for compliance could void the user's authority to operate the equipment.

This class B device complies with Canadian Interference-Causing Equipment Standard ICES-003: CAN ICES-003(B) / NMB-003(B)

Conformité à Innovation, Sciences et Développement Économique Canada (ISDE)

L'émetteur/recepteur exempt de licence contenu dans le présent appareil est conforme aux CNR d'Innovation, Sciences et Développement économique Canada applicables aux appareils radio exempts de licence. L'exploitation est autorisée aux deux conditions suivantes: (1) L'appareil ne doit pas produire de brouillage; (2) L'appareil doit accepter tout brouillage radioélectrique subi, même si le brouillage est susceptible d'en compromettre le fonctionnement. Les changements ou modifications non expressément approuvés par la partie responsable de la conformité pourraient annuler l'autorité de l'utilisateur à faire fonctionner l'équipement.

Cet appareil numérique de classe B est conforme à la Norme sur le Matériel Brouilleur NMB-003 du Canada: CAN ICES-003(B) / NMB-003(B)

Notice for the European Union

The kit X-NUCLEO-NFC09A1 is in conformity with the essential requirements of the Directive 2014/53/EU (RED) and of the Directive 2015/863/EU (RoHS). Applied harmonized standards are listed in the EU Declaration of Conformity.

Notice for the United Kingdom

The kit X-NUCLEO-NFC09A1 is in compliance with the UK Radio Equipment Regulations 2017 (UK SI 2017 No. 1206 and amendments) and with the Restriction of the Use of Certain Hazardous Substances in Electrical and Electronic Equipment Regulations 2012 (UK SI 2012 No. 3032 and amendments). Applied standards are listed in the UK Declaration of Conformity.

Revision history

Table 5. Document revision history

Date	Revision	Changes
01-Oct-2024	1	Initial release.
25-Oct-2024	2	Updated Section 1.1: Overview .

Contents

1	Getting started	2
1.1	Overview	2
1.2	Board connection	2
1.3	Hardware requirements	2
1.4	System requirements	2
2	Board setup	3
3	Hardware	4
3.1	Host interface and GPIO connection	4
3.2	X-NUCLEO-NFC09A1 expansion board component placement	5
3.3	ST25R100 device	5
4	Schematic diagrams	6
5	Bill of materials	9
6	Board versions	13
7	Regulatory compliance information	14
	Revision history	15
	List of tables	17
	List of figures	18

List of tables

Table 1.	Interconnections between the X-NUCLEO-NFC09A1 expansion board and the NUCLEO-G071RB board (left side)	4
Table 2.	Interconnections between the X-NUCLEO-NFC09A1 expansion board and the NUCLEO-G071RB board (right side)	4
Table 3.	X-NUCLEO-NFC09A1 bill of materials	9
Table 4.	X-NUCLEO-NFC09A1 versions	13
Table 5.	Document revision history	15

List of figures

Figure 1.	X-NUCLEO-NFC09A1 expansion board	1
Figure 2.	X-NUCLEO-NFC09A1 component placement	5
Figure 3.	X-NUCLEO-NFC09A1 circuit schematic (1 of 3)	6
Figure 4.	X-NUCLEO-NFC09A1 circuit schematic (2 of 3)	7
Figure 5.	X-NUCLEO-NFC09A1 circuit schematic (3 of 3)	8

IMPORTANT NOTICE – READ CAREFULLY

STMicroelectronics NV and its subsidiaries (“ST”) reserve the right to make changes, corrections, enhancements, modifications, and improvements to ST products and/or to this document at any time without notice. Purchasers should obtain the latest relevant information on ST products before placing orders. ST products are sold pursuant to ST’s terms and conditions of sale in place at the time of order acknowledgment.

Purchasers are solely responsible for the choice, selection, and use of ST products and ST assumes no liability for application assistance or the design of purchasers’ products.

No license, express or implied, to any intellectual property right is granted by ST herein.

Resale of ST products with provisions different from the information set forth herein shall void any warranty granted by ST for such product.

ST and the ST logo are trademarks of ST. For additional information about ST trademarks, refer to www.st.com/trademarks. All other product or service names are the property of their respective owners.

Information in this document supersedes and replaces information previously supplied in any prior versions of this document.

© 2024 STMicroelectronics – All rights reserved