

## Getting started with the STEVAL-C34KAT2, iNemo inertial module with embedded ISPU and temperature sensor expansion kit

### Introduction

The **STEVAL-C34KAT2** is a multisensing expansion kit that includes the STEVAL-C34AT02 expansion board and a flex cable.

The **ISM330IS** sensor is soldered at the center of the small 25 x 25 mm board. The **STTS22H** temperature sensor is placed on the PCB side and is thermally coupled to the PCB bottom exposed pad through vias.

The **ISM330IS** is a system-in-package featuring a 3-axis digital accelerometer and a 3-axis digital gyroscope, boosting performance at 0.59 mA in high-performance mode and enabling always-on low-power features for optimal motion results in industrial and IoT solutions.

The **ISM330IS** embeds a new ST category of processing intelligent sensor processing unit (ISPU) to support real-time applications that rely on sensor data.

The ISPU is an ultra-low-power, high-performance programmable core, which can execute signal processing and AI algorithms in the edge. The main benefits of the ISPU are C programming and an enhanced ecosystem with libraries and third-party tools/IDE.

Its optimized ultra-low-power hardware circuitry for real-time execution of the algorithms is a state-of-the-art feature for any wireless sensor node from small equipment or accessories to enterprise solutions for industry 5.0 (anomaly detection, asset tracking, factory automation).

The expansion board can be mounted on the equipment for the vibration analysis using the four holes or the double-sided adhesive tape. This board is compatible with the STWIN.box kit (**STEVAL-STWINBX1**).

Figure 1. STEVAL-C34KAT2 expansion kit

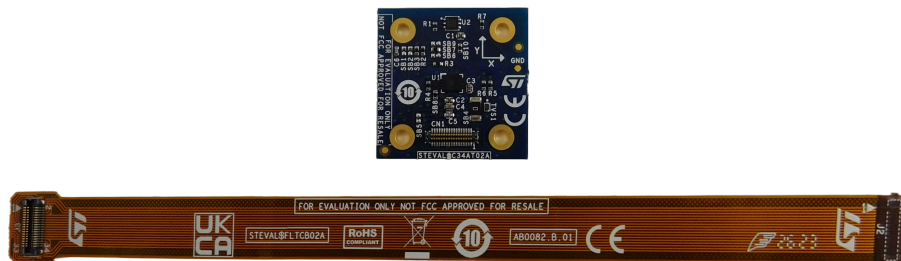

## 1 Features

- Kit content:
  - a STEVAL-C34AT02 multisensing expansion board (25x25mm) with a 34-pin board-to-FPC connector
  - a 34-pin flex cable
- Ideal plug-in for the [STEVAL-STWINBX1](#) evaluation board
- iNEMO inertial module with embedded ISPU (ISM330IS):
  - 3-axis accelerometer with selectable full scale:  $\pm 2/\pm 4/\pm 8/\pm 16$  g
  - 3-axis gyroscope with selectable full scale:  $\pm 125/\pm 250/\pm 500/\pm 1000/\pm 2000$  dps
  - Embedded ISPU: ultra-low-power, high-performance programmable core to execute signal processing and AI algorithms in the edge for a seamless digital-life experience
  - Low-power consumption: 0.59 mA in high-performance mode, 0.46 mA in low-power mode (gyroscope + accelerometer only, ISPU not included)
- Low-voltage, ultra-low-power, 0.5°C accuracy I<sup>2</sup>C/SMBus 3.0 temperature sensor ([STTS22H](#))
  - Programmable thresholds through an interrupt pin
  - Ultra-low current: 1.75  $\mu$ A in one-shot mode
  - Operating temperature -40 to +125°C
- Exposed pad on the bottom side to improve the thermal coupling for the temperature sensor
- 1.8 to 3.3 V power supply input

---

## 2 Precautions for use

---

*Important:* This kit is not immune to indirect electrostatic discharges. During the ESD test, the kit has obtained level C. This means that the expansion board has not been damaged during the test, but the intervention of the operator was necessary to reset it. When an electrostatic discharge is applied to an adjacent object, the board might interrupt its functioning. In this case, the intervention of an operator is required to reset the board (that is, to unplug and replug the power supply line).

If the board is attached to a [STEVAL-STWINBX1](#) (STWIN.box), you can control the power supply of the external 34-pin connector via software, by leveraging the power switch functionality of the [STBC02](#) battery charger IC.

### 3 How to use the kit

The [STEVAL-C34KAT2](#) expansion board can be used with the [STEVAL-STWINBX1](#) kit (STWIN.box). The device can be attached to the STWIN.box using the provided flex cable, through the 34-pin connectors available on both platforms.

**Figure 2. Expansion board and flex cable**



To plug the flex cable onto the STWIN.box, remove the plastic case cover.

**Figure 3. Plugging the flex cable onto the STWIN.box**



You can then remount the cover, as it leaves enough space for the flex cable.

**Figure 4. Final setup**



The easiest way to read data from the [STEVAL-C34KAT2](#) sensors is to flash the STWIN.box with the [FP-SNS-DATALOG2](#) function pack. The firmware package provides a ready to use, precompiled binary to perform sensor data acquisition.

*Note: Please be careful when you remove the flex cable as you may damage it. The safest way to remove it is by pulling it next to the connectors using tweezers.*

**Figure 5. How remove the flex cable**

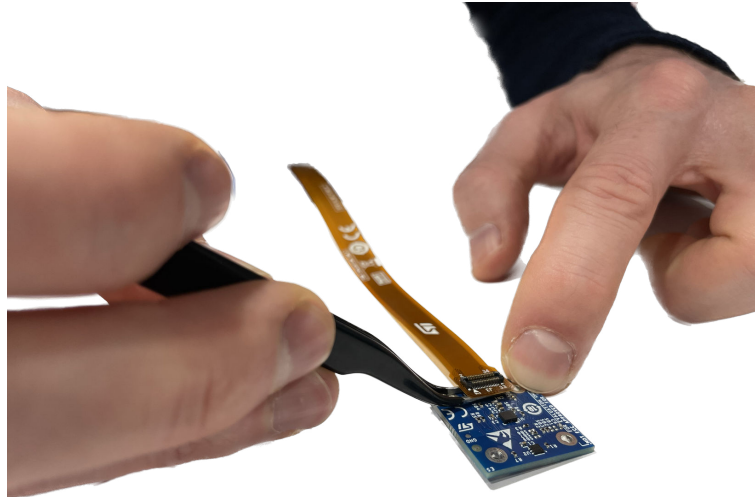

## 4 Adhesive tape

The kit provides a few samples of 3M™ 9088 high performance, double coated tape. These samples can be used to mount the board on the equipment for vibration analysis.

Alternatively, you can mount the board through the holes located at each corner of the PCB.

Figure 6. Adhesive tape



# 5 Schematic diagrams

Figure 7. STEVAL-C34KAT2 circuit schematic: STEVAL-C34AT02

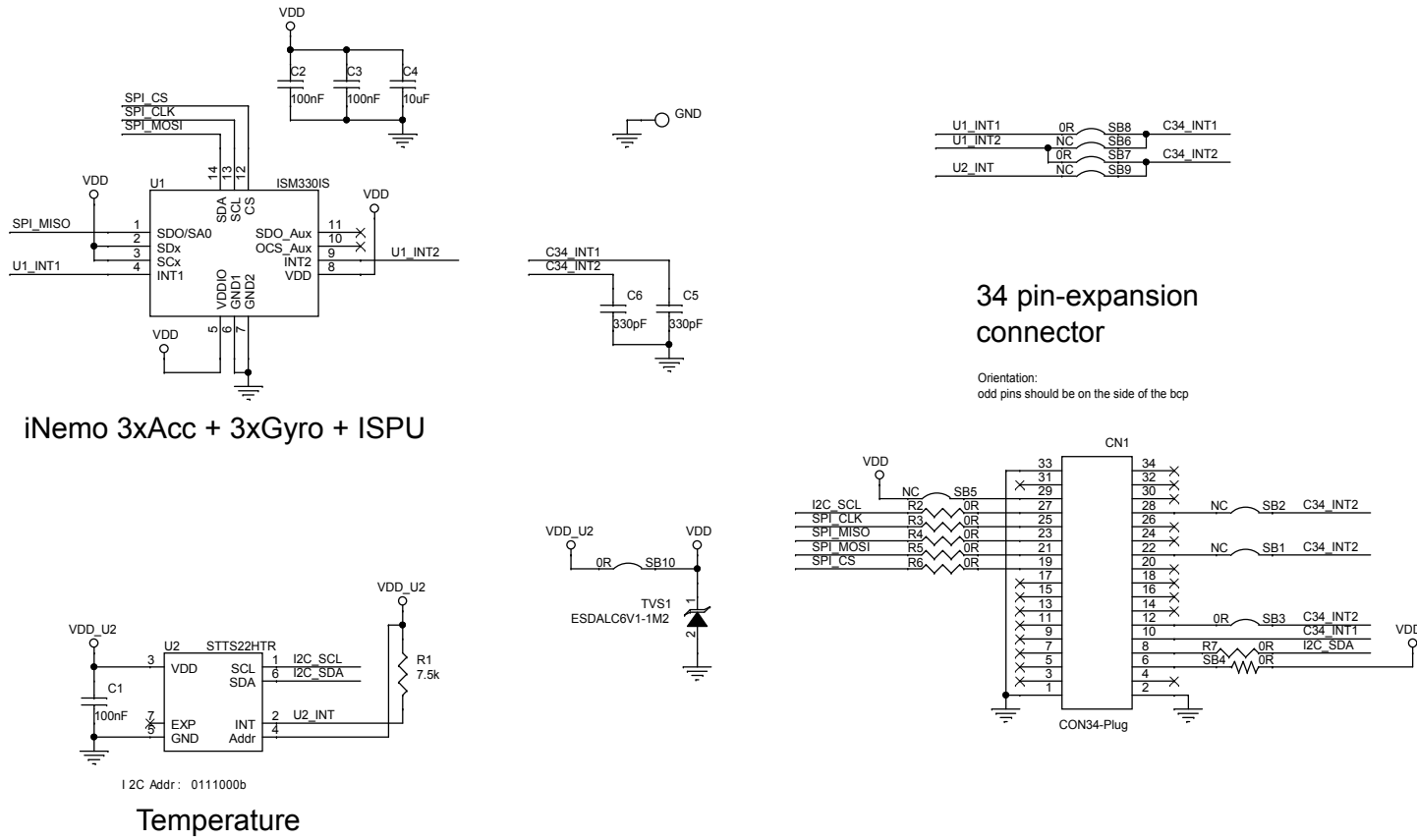

iNemo 3xAcc + 3xGyro + ISPU

Temperature



Figure 8. STEVAL-C34KAT2 circuit schematic: STEVAL-FLTCB02

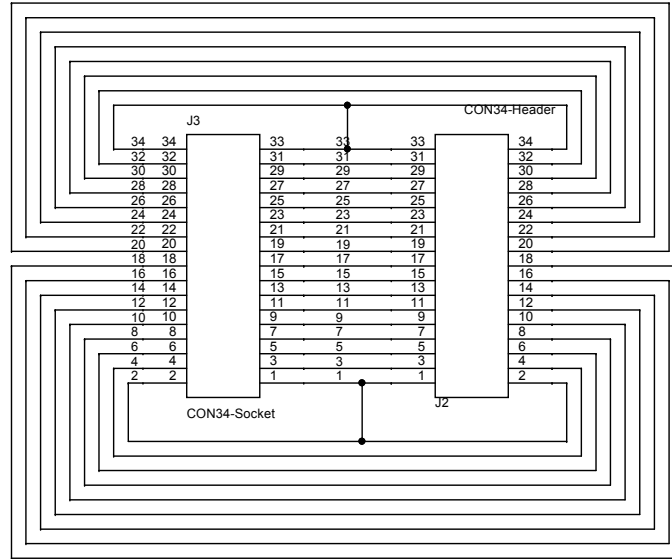
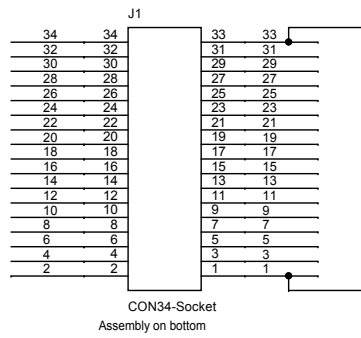



## 6 Bill of materials

**Table 1. STEVAL-C34KAT2 bill of materials**

Item	Q.ty	Ref.	Part/value	Description	Manufacturer	Order code
1	1	Table 2. Expansion board bill of materials	STEVAL-C34AT02	Vibrometer and temperature expansion board	ST	Not available for separate sale
2	1	Table 3. Flex cable bill of materials	STEVAL-FLTCB02	34-pin, 15 cm flex cable	ST	Not available for separate sale
3	4	-	3M 9088 - 25x25 mm, 25x25 mm	3M™ high-performance, double coated tape	3M	9088

**Table 2. Expansion board bill of materials**

Item	Q.ty	Ref.	Value	Description	Manufacturer	Order code
1	1	CN1	CON34-Plug	CONN SOCKET 34POS SMD GOLD	8Panasonic Electric Works	AXF6G3412A
2	C1,C2,C3	C1,C2,C3	100nF, 0402 (1005 Metric), +/-10%	CAP CER 0.1UF 16V X7R 0402	Murata Electronics North America	GRM155R71C104KA8 8J
3	1	C4	10uF, 0402 (1005 Metric), +/-20%	CAP CER 10UF 10V X5R 0402	Samsung Electro-Mechanics America, Inc.	CL05A106MP8NUB8
4	2	C5,C6	330pF, 0402 (1005 Metric), +/-10%	CAP CER 330pF	Murata Electronics North America	GRM1555C1H331GA0 1D
5	1	GND	TP (not mounted)	TEST POINT 1MM SMD PADSTASCK		
6	1	R1	7.5k, 0402 (1005 Metric), +/-5%	RES SMD 7.5K OHM 5% 1/16W 0402	Yageo	RC0402JR-077K5L
7	10	R2,SB3,R3,R4,R5,R6,SB7,R7,SB8,SB10	0R, 0402 (1005 Metric)	RES SMD 0 OHM 0402	Vishay Dale	CRCW04020000Z0ED
8	5	SB1,SB2,SB5,SB6,SB9	NC, 0402 (1005 Metric), (not mounted)	RES SMD 0 OHM 0402	Vishay Dale	CRCW04020000Z0ED
9	1	SB4	0R, 1206	CHIP RES. 0R 1206 1/4W 5%	Yageo	AF1206JR-070RL
10	1	TVS1	ESDALC6V1-1M2, SOD882	DIODO TVS TRANSIL UNIDIR. 50W 6.1V	ST	ESDALC6V1-1M2
11	1	U1	ISM330ISNTR, LGA-14L	Accelerometer Ultra Wide Bandwidth	ST	ISM330ISNTR
12	1	U2	STTS22HTR, UDFN-6L	Digital temperature sensor	ST	STTS22HTR

**Table 3. Flex cable bill of materials**

Item	Q.ty	Ref.	Part/value	Description	Manufacturer	Order code
1	1	J1	CON34-Socket, 1 A/pin (for power) 0.5 A/pin (for signal)	CONN SOCKET 34POS SMD GOLD	Panasonic Electric Works	AXF5G3412A
2	1	J3	CON34-Socket, 1 A/pin (for power) 0.5 A/pin (for signal)	CONN SOCKET 34POS SMD GOLD	Panasonic Electric Works	AXF5G3412A
3	1	J2	CON34-Header, 1 A/pin (for power) 0.5 A/pin (for signal)	CONN HDR 34POS SMD GOLD	Panasonic Electric Works	AXF6G3412A
4	1	FLEX PCB, Not Reference	FLEX PCB 3 LAYER, size 9.95x150x0.337 mm	FLEX Support- DUPONT Kapton Polyimide Film	DUPONT	

## 7 Kit versions

**Table 4. STEVAL-C34KAT2 versions**

PCB version	Schematic diagrams	Bill of materials
STEVAL\$C34KAT2A <sup>(1)</sup>	STEVAL\$C34KAT2A schematic diagrams	STEVAL\$C34KAT2A bill of materials

- This code identifies the STEVAL-C34KAT2 evaluation kit first version. The kit consists of the STEVAL-C34AT02 expansion board whose version is identified by the code STEVAL\$C34AT02A and the STEVAL-FLTCB02 flex cable whose version is identified by the code STEVAL\$FLTCB02A. The STEVAL\$C34AT02A code is printed on the expansion board PCB. The STEVAL\$FLTCB02A code is printed on the flex cable.*

## 8 Regulatory compliance information

### Formal Notice Required by the U.S. Federal Communications Commission

#### FCC NOTICE

This kit is designed to allow:

- (1) Product developers to evaluate electronic components, circuitry, or software associated with the kit to determine whether to incorporate such items in a finished product and
- (2) Software developers to write software applications for use with the end product.

This kit is not a finished product and when assembled may not be resold or otherwise marketed unless all required FCC equipment authorizations are first obtained. Operation is subject to the condition that this product not cause harmful interference to licensed radio stations and that this product accept harmful interference. Unless the assembled kit is designed to operate under part 15, part 18 or part 95 of this chapter, the operator of the kit must operate under the authority of an FCC license holder or must secure an experimental authorization under part 5 of this chapter 3.1.2.

### Formal Product Notice Required by Industry Canada Innovation, Science and Economic Development

#### Canada compliance:

For evaluation purposes only. This kit generates, uses, and can radiate radio frequency energy and has not been tested for compliance with the limits of computing devices pursuant to Industry Canada (IC) rules.

À des fins d'évaluation uniquement. Ce kit génère, utilise et peut émettre de l'énergie radiofréquence et n'a pas été testé pour sa conformité aux limites des appareils informatiques conformément aux règles d'Industrie Canada (IC).

### Formal product notice required by EU

This device is in conformity with the essential requirements of the Directive 2014/30/EU (EMC) and of the Directive 2015/863/EU (RoHS).

## Revision history

**Table 5. Document revision history**

Date	Revision	Changes
28-Sep-2023	1	Initial release.

---

## Contents

<b>1</b>	<b>Features</b> .....	<b>2</b>
<b>2</b>	<b>Precautions for use</b> .....	<b>3</b>
<b>3</b>	<b>How to use the kit</b> .....	<b>4</b>
<b>4</b>	<b>Adhesive tape</b> .....	<b>6</b>
<b>5</b>	<b>Schematic diagrams</b> .....	<b>7</b>
<b>6</b>	<b>Bill of materials</b> .....	<b>9</b>
<b>7</b>	<b>Kit versions</b> .....	<b>11</b>
<b>8</b>	<b>Regulatory compliance information</b> .....	<b>12</b>
	<b>Revision history</b> .....	<b>13</b>
	<b>List of tables</b> .....	<b>15</b>
	<b>List of figures</b> .....	<b>16</b>

## List of tables

<b>Table 1.</b>	STEVAL-C34KAT2 bill of materials . . . . .	9
<b>Table 2.</b>	Expansion board bill of materials . . . . .	9
<b>Table 3.</b>	Flex cable bill of materials . . . . .	10
<b>Table 4.</b>	STEVAL-C34KAT2 versions . . . . .	11
<b>Table 5.</b>	Document revision history . . . . .	13

## List of figures

Figure 1.	STEVAL-C34KAT2 expansion kit. . . . .	1
Figure 2.	Expansion board and flex cable . . . . .	4
Figure 3.	Plugging the flex cable onto the STWIN.box. . . . .	4
Figure 4.	Final setup. . . . .	4
Figure 5.	How remove the flex cable . . . . .	5
Figure 6.	Adhesive tape . . . . .	6
Figure 7.	STEVAL-C34KAT2 circuit schematic: STEVAL-C34AT02 . . . . .	7
Figure 8.	STEVAL-C34KAT2 circuit schematic: STEVAL-FLTCB02 . . . . .	8



**IMPORTANT NOTICE – READ CAREFULLY**

STMicroelectronics NV and its subsidiaries (“ST”) reserve the right to make changes, corrections, enhancements, modifications, and improvements to ST products and/or to this document at any time without notice. Purchasers should obtain the latest relevant information on ST products before placing orders. ST products are sold pursuant to ST’s terms and conditions of sale in place at the time of order acknowledgment.

Purchasers are solely responsible for the choice, selection, and use of ST products and ST assumes no liability for application assistance or the design of purchasers’ products.

No license, express or implied, to any intellectual property right is granted by ST herein.

Resale of ST products with provisions different from the information set forth herein shall void any warranty granted by ST for such product.

ST and the ST logo are trademarks of ST. For additional information about ST trademarks, refer to [www.st.com/trademarks](http://www.st.com/trademarks). All other product or service names are the property of their respective owners.

Information in this document supersedes and replaces information previously supplied in any prior versions of this document.

© 2023 STMicroelectronics – All rights reserved