

## User manual for ready-to-use evaluation kit based on universal ST25R200 NFC device for contactless applications

### Introduction

The [STEVAL-25R200SA](#) is a ready-to-use kit based on the ST25R200 high-performance NFC universal device for contactless applications.

The kit allows evaluating the ST25R200 features and functionality in the reader/writer modes.

Presented in the form of a single divisible card (STEVAL-25R200A), the kit consists of:

- The core system designed for basic evaluations of the reader performances and features composed of:
  - ST25R200 module main board that embeds the ST25R200 device and an STM32 G0 processor
  - STLink companion board that includes an ST-LINK in-circuit debugger and programmer for the STM32.
  - Main NFC antenna 20x20 mm etched on the PCB with its tuning circuit.
- The complementary antennas are designed for testing various topologies that can substitute the main NFC antenna:
  - Dual antenna hub with two 12 x 12 mm tuned antennas for evaluating the ST25R200 dual antenna feature.
  - Flexible antenna board tuned for being connected to the flexible antenna delivered with the kit.
  - 50-ohm antenna interface board tuned for being connected to any 50-ohm NFC antenna available on the market.
- The tag boards for reader and tag system evaluation:
  - Tag 1: ST25TV board that embeds an ST25TV with its tuned 10 x 5 mm antenna
  - Tag 2: ST25TN board that embeds an ST25TN with its tuned 10 x 5 mm antenna

These eight boards are breakable for composing and evaluating various combinations.

A connector is present on all subsystems for a quick and robust connection to the system core. It is based on the ST25R200 and the STM32, which includes hardware and software tools that enable using the entire STM32 ecosystem.

This board is powered through a micro-USB connector.

Thanks to several demonstrations that can be performed, this kit helps the users develop and test their applications.

The board is configured to support ISO14443A/B, and ISO15693 communication.

The [ST25R200](#) manages frame coding and decoding in reader mode for standard applications, such as NFC, proximity, and vicinity HF RFID standards. It supports ISO/IEC 14443 type A/B and ISO/IEC 15693 RF communication protocols as well as the detection, reading and writing of NFC forum type 1, 2, 4, and 5 tags.

It contains a low power wake-up system capable of detecting an approaching tag. It also contains a low power RC Oscillator and wake-up timer to automatically wake-up the device after a selected time period and check for a tag presence.

The kit is FCC certified, with FCC ID: YCPR200AD1. It is also IC certified, with IC: 8976A-R200AD1; PMN: STEVAL-25R200A; HVIN: STEVAL-25R200A.

Figure 1. STEVAL-25R200A top side

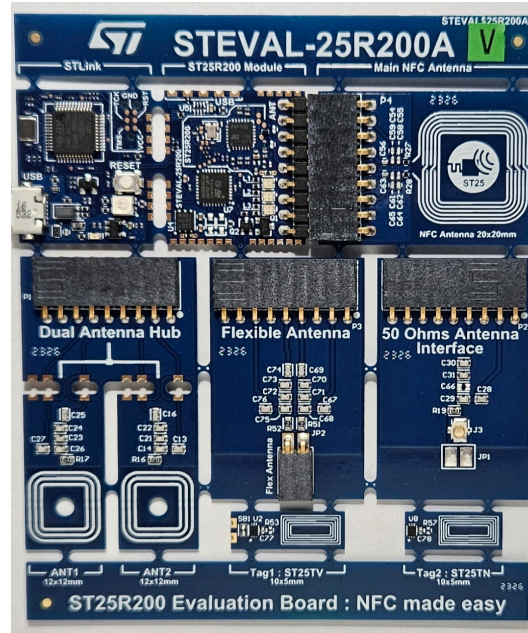

Notice: For dedicated assistance, submit a request through our online support portal at [www.st.com/support](http://www.st.com/support).

## 1 Features

---

- On-board NFC card reader IC: [ST25R200](#)
  - Operating modes : Reader/Writer
  - ISO14443A, ISO14443B and ISO15693 compliant general purpose NFC device
  - Supports NFC Forum T1T, T2T, T4T and T5T tag types
  - Possibility of driving two antennas in single-ended configuration
  - RC low power wake-up
- Five 13.56 MHz inductive antennas etched on PCB and associated tuning circuits.
- Two tag boards with the chip soldered and the antenna etched on PCB with its associated tuning circuit.
- A board dedicated to the ST-LINK in-circuit debugger and programmer for the STM32
- Free comprehensive firmware library compatible with [STM32Cube](#) and examples for [ST25R200](#)
- CE, UKCA, FCC, ISED certified
- RoHS and WEEE compliant

## 2 Hardware overview

### 2.1 STEVAL-25R200SA kit usage

#### 2.1.1 Kit content

The kit can be divided into three segments:

1. The reader system consisting of:
  - The STLink debugger that powers and link the boards through a micro-USB connector to a computer with a graphical user interface running. This firmware is available on ST.com.
  - The ST25R200 module that embeds an STM32 and the ST25R200.
2. The various antennas. Depending on the user application they can be connected to the reader system.
3. The tags. Available in PCB or sticker format to simulate a final application.

#### 2.1.2 Option

You can connect a 50-Ω antenna of your desired brand and form factor. The footprint also allows connecting and matching fully customized antennas.

#### 2.1.3 kit usage overview

Figure 2. STEVAL-25R200SA composition

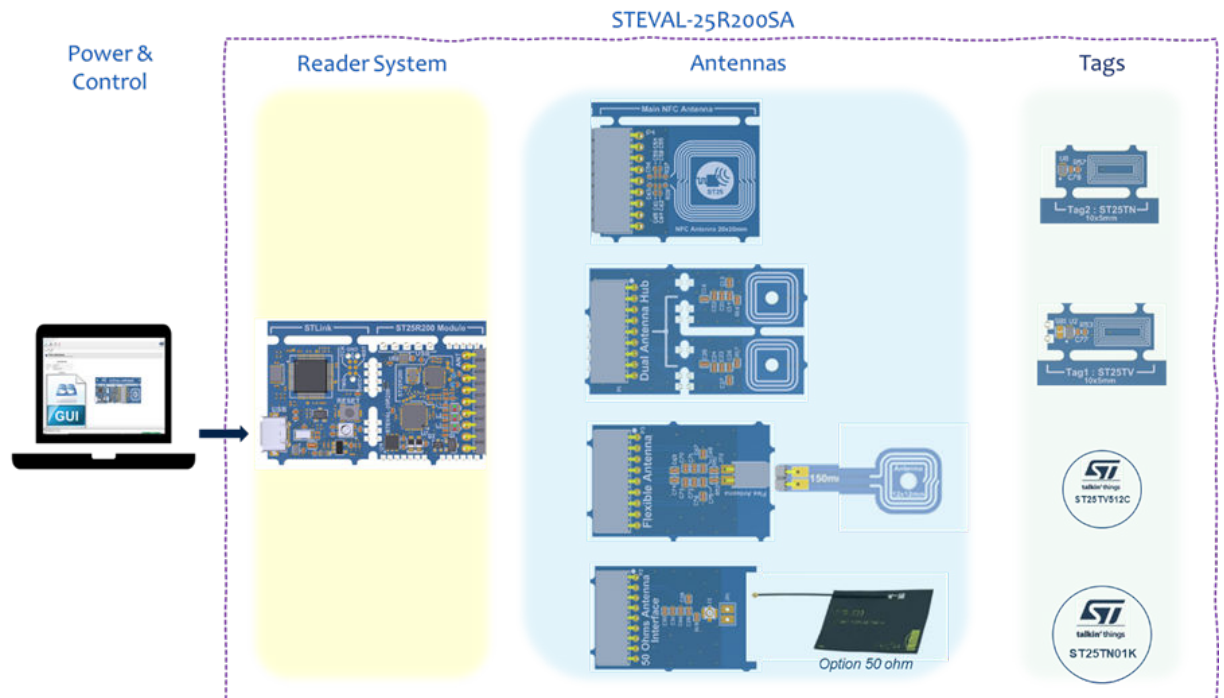

## 2.2 The core system

### 2.2.1 Core system boards

Figure 3. Core system boards

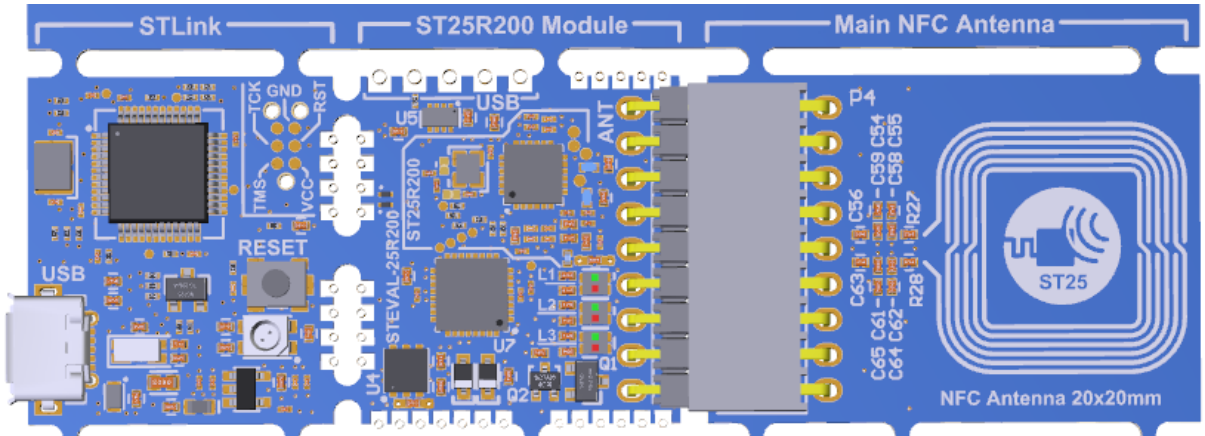

### 2.2.2 STLink board

The STLink is the in-circuit debugger and programmer for the STM32G0 microcontroller located on the ST25R200 module application board. The serial wire debugging (SWD) is the bus interface for this communication. It also provides a Virtual COM port interface allowing the host PC to communicate with the target microcontroller through a UART.

STM32 applications use the USB full-speed interface to communicate with the STM32CubeIDE software tool or ST25R200 GUI running on the host PC.

The 5 V supply of the USB bus powers the boards. An LDO converts this voltage down to 3.3 V to supply the microcontroller and the ST25R200. A green LED indicates when the board is powered.

The board is breakable and can be used independently. On the back side, the PCB pad signal names are indicated for wire connections or for a solderable system module.

Figure 4. STLink top and bottom side

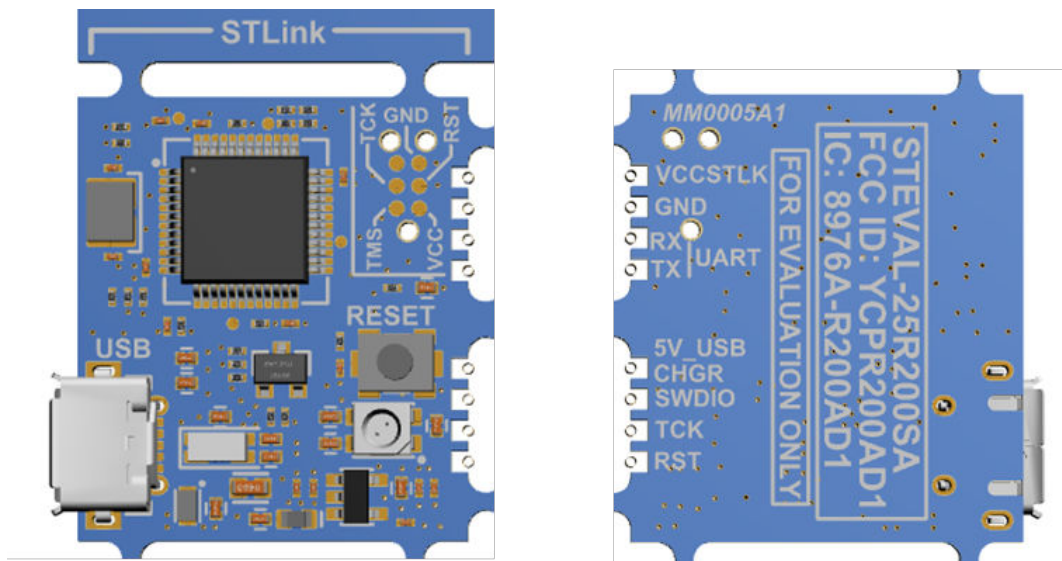

### 2.2.3 ST25R200 module

#### 2.2.3.1 Presentation

The ST25R200 module embeds the ST25R200 reader device and a STM32G0B1KEUxN processor.

The 5 V supply of a USB bus powers the boards. Usually, the board is powered by the STLink board. If the ST25R200 module is used separately, other possibilities are offered (Table 2).

An LDO converts the voltage applied down to 3.3 V to supply the microcontroller and the ST25R200.

A connector allows to plug an antenna. Five antennas are delivered with kit, the main NFC Antenna of 20x25 mm size etched on the PCB with its tuning circuit is delivered connected to the ST25R200 module (Table 1).

This board is breakable and can be used independently. On the back side the PCB pads signals names are indicated for wires connections or for a solderable system module (Figure 2).

Thanks to the STM32G0 IOs modularity the pins can be used for different configurations; a pre-assignment is proposed with associated IP functions, but alternate functions can be chosen too (Table 3).

Three bi-color LEDs are available for indicating events, by default they are assigned to the demo by the firmware. Two footprints are provided for using the board in standalone mode, a USB and an STLink.

Figure 5. ST25R200 module top and bottom side

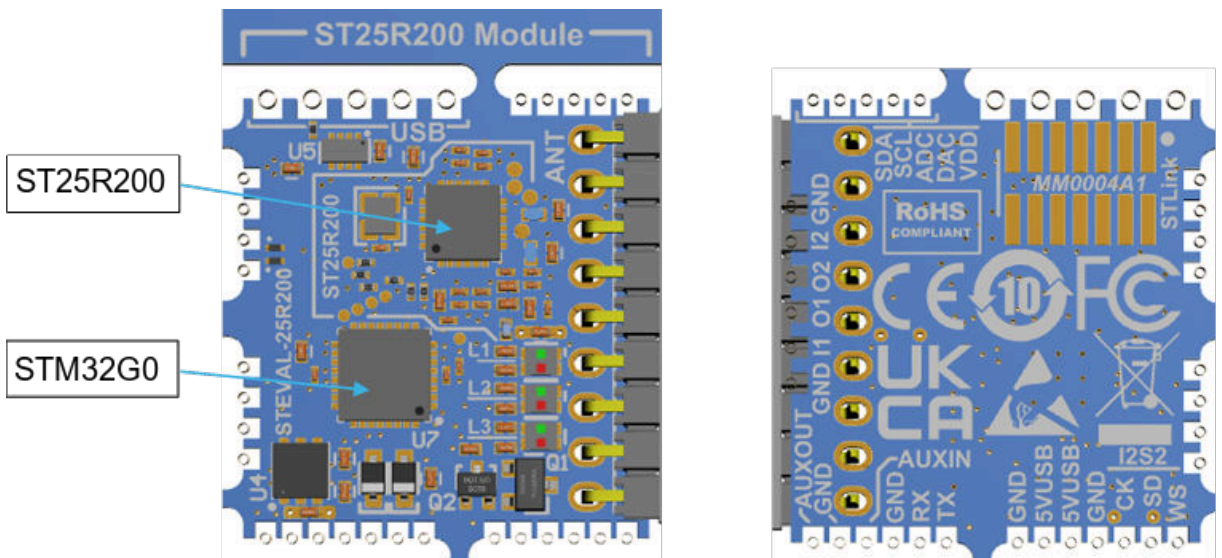

Table 1. RF connector

J4 Pins TSW-109-08-G-S-NA	Signal
1	Gnd
2	RFI2
3	Gnd
4	RFO2
5	RFO1
6	Gnd
7	RFI1
8	Gnd
9	Gnd

**Table 2. List of PCB pads**

PCB pads	STM32 IPs	STM32 IOs	
ADC	ADC1_IN1	PA1	
DAC	DAC1_OUT1	PA4	
USB_DM	USB_DM	PA11	
USB_DP	USB_DP	PA12	
WS	I2S2_WS	PD0	
CK	I2S2_CK	PD1	
SD	I2S2_SD	PB15	
SCL	I2C1_SCL	PB6	
SDA	I2C1_SDA	PB7	
TX	USART6_TX	PB8	
RX	USART6_RX	PB9	
AUXOUT	GPIO_Output	PD3	Transistor Drain <sup>(1)</sup>
AUXIN			Transistor Source <sup>(1)</sup>

1. See schematic

**Table 3. Board powering**

PCB Pad	Schematic	5 v Input for 3.3 v ST25R200 Module	3.3 v Output	Description
	V-USB	X		Optional + 5V USB input
5VUSB	5V_USB_CHGR	X		+ 5V
VDD	VDD_STM32		X	Regulator 3.3V Output

**Table 4. STLink to ST25R200 module**

PCB pads	Signal	Description
1	VCCSTLK	Vcc STLink
2	GND	Gnd
3	RX UART	RX UART G0
4	TX UART	TX UART G0
5	5V_USB CHGR	5V USB STLink
6	SWDIO	Bi-directional Serial Wire Debug data pin.
7	TCK	STLink Clock signal to G0
8	RST	nRESET G0

### 2.2.3.2 Optional USB

The footprint proposed allows soldering a five-pin HE14 connector for many development boards with micro-USB 2.0 available on the market.

Figure 6. Optional USB

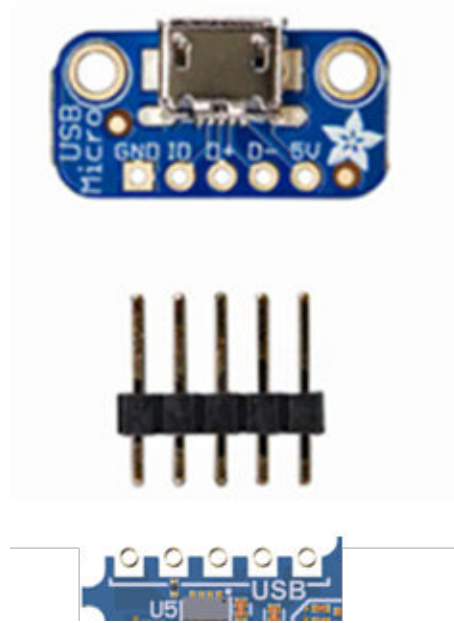

### 2.2.3.3 Optional STLink V3 connector

The footprint proposed allows soldering a Samtec FTSH-107-01-L-DV-K-A connector for a debug connector with STDC14 available with the STlink-V3 family probe.

Figure 7. STLink V3 connector

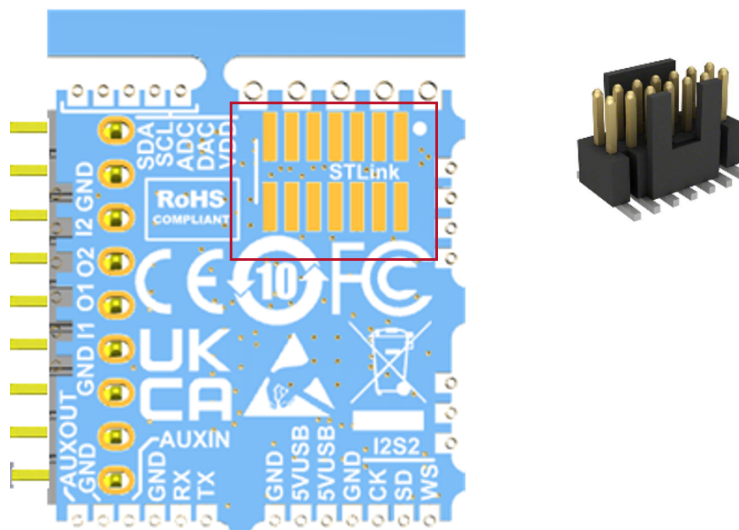



## 2.2.4 Main NFC antenna

Figure 8. Main NFC antenna



This board embeds a connector and a 20x20 mm antenna etched on the PCB with its tuning circuit. The EMC filter is present on the ST25R200 module, the matching circuit on the Main NFC antenna (Figure 8)

Figure 9. STEVAL-25R200 reader RF path repartition

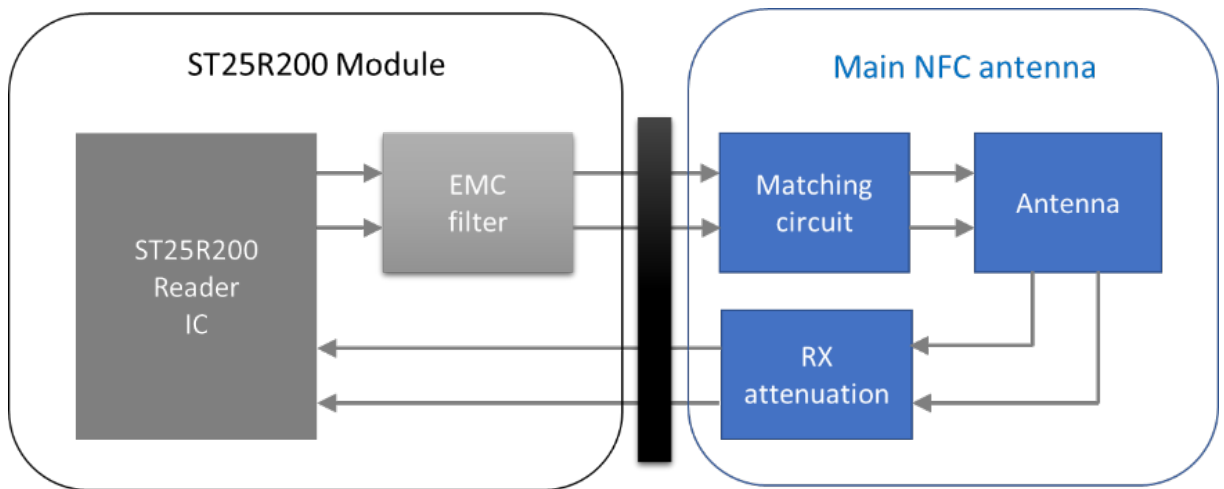

## 2.3 Complementary antennas

### 2.3.1 Dual antenna hub

The dual hub antenna consists of a connector, a PCB hub, and two 12 x 12 mm tuned antennas. Each antenna is etched on a PCB with its tuning circuit for evaluating the ST25R200 dual antenna feature. The three subsystems are breakable with the interfaces between boards accessible through PCB pads, and signals are referenced. The connector allows direct connection to the main board ST25R200 module to replace the main NFC antenna.

Figure 10. Dual antenna hub

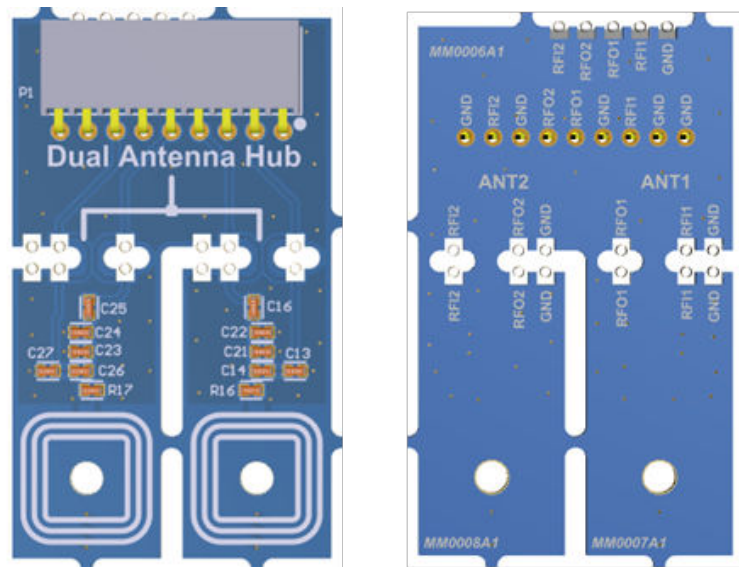

### 2.3.2 Flexible antenna

The flexible antenna board consists of two connectors and a PCB with the tuning circuit for the flex antenna delivered with the STEVAL kit.

The first connector allows direct connection to the main board ST25R200 module to replace the main NFC antenna; the second is dedicated to the flex antenna connection.

The flex antenna is delivered separately in the package and can be cut for different uses case requirements.

Figure 11. Flexible antenna

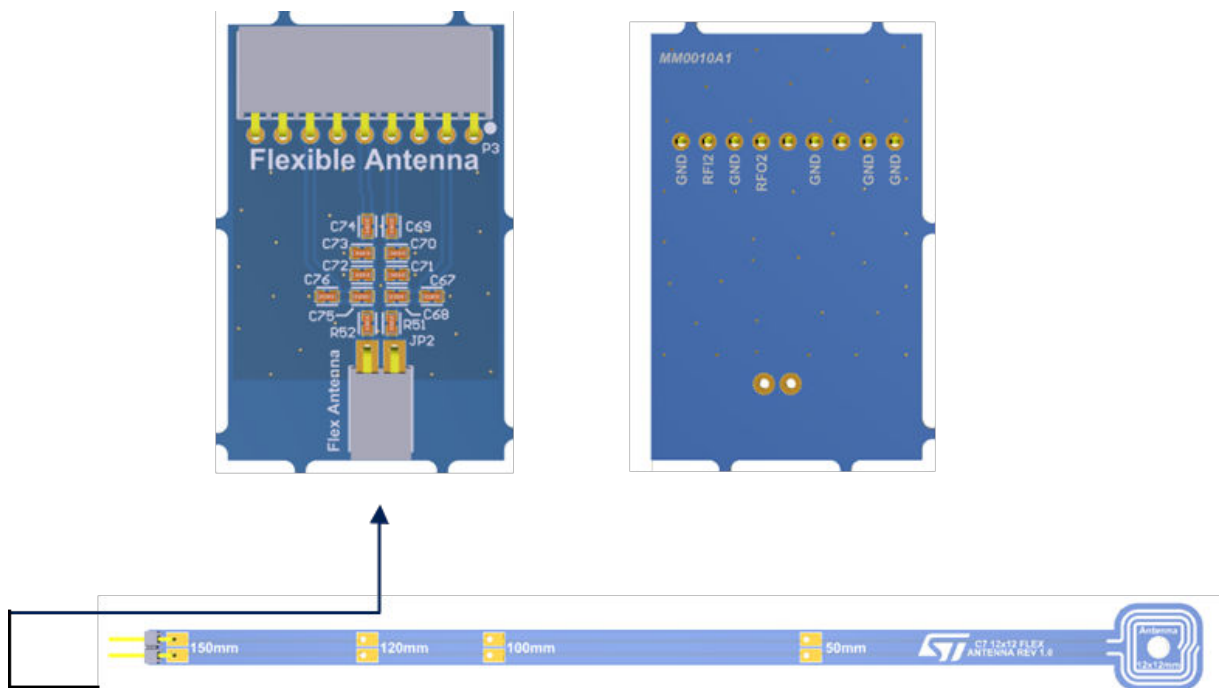

### 2.3.3 50-ohm antenna

The 50-ohm antenna consists of a connector and a PCB with the tuning circuit and pads for a 50-ohm antenna NOT delivered with the STEVAL kit, but available on the market.

The connector allows a direct connection to the main board ST25R200 module to replace the main NFC antenna; the pads are dedicated to the 50-ohm antenna connection.

If a 50-Ω antenna is not being used, the footprint of the components can be used to match a custom antenna.

Figure 12. 50-ohm antenna

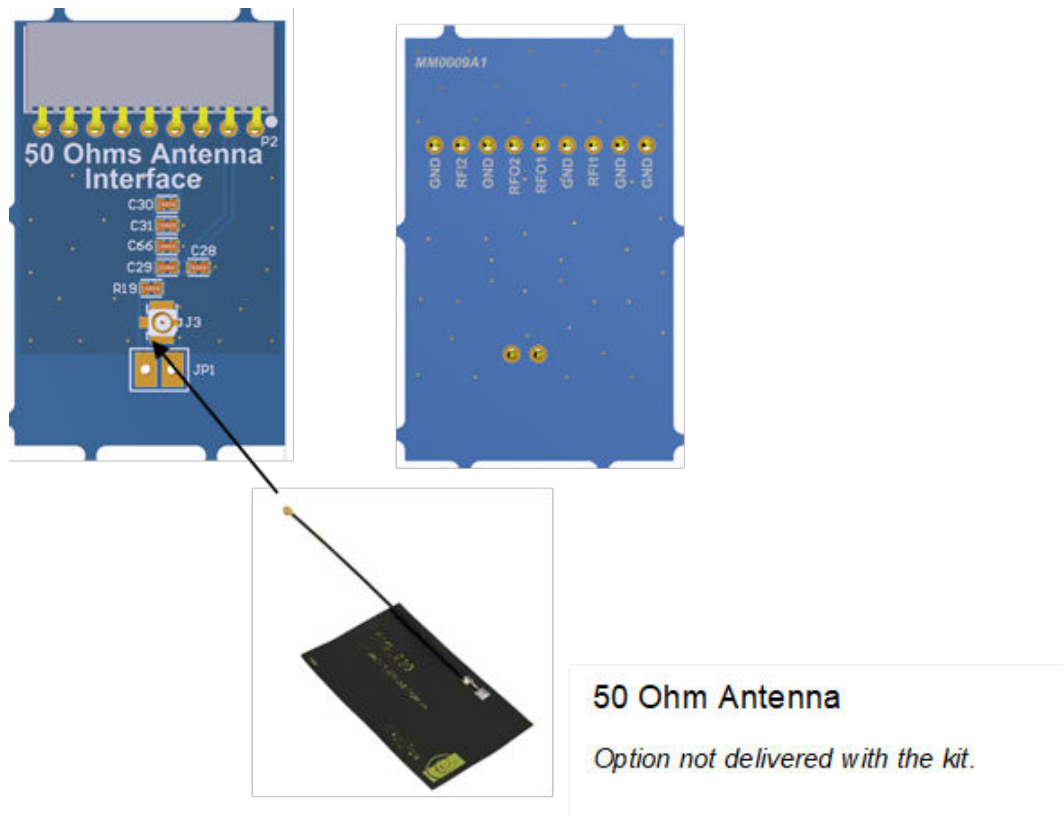

## 2.4 Antenna tuning

Tuning compatible with all the antennas delivered imposes a tradeoff due to the presence of the EMC filter on the main board. Optimum matching is not delivered for each antenna and manual fine tuning is required. Dedicated tools and tuning application notes are available on ST web site.

*Note:* The antenna impedance must be calculated to remain below 250mA. Normally, it should be the case for 18-20 ohm tuning.

## 2.5 NFC tags

The tag boards are available for reader&tag system evaluation.

The antennas delivered are very small, which can impact the reader plus tag system if the application requires a long range. In this case, please refer to the design recommendations provided on the ST website [NFC](#).

### 2.5.1 Tag 1: ST25TV

This board embeds a ST25TV (ST25TV02K-CAFH3 UFDFPN5) with its tuned 10 x 5mm antenna.

Two PCB pads are available for temper detect evaluation TD0 & TD1. To use them, the solder bridge SB1 must be removed.

Figure 13. ST25TV board

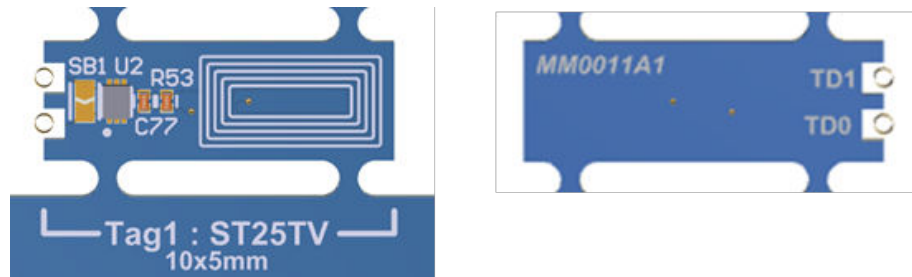

#### 2.5.1.1 Use cases

Product Identification, asset tracking, consumer engagement, access control, gaming, tamper proof applications, and brand protection.

#### 2.5.1.2 Key features

- ISO15693 and NFC Type V (long range operations, up to 53kb/s)
- Augmented NDEF: UID, NFC tap counter, tamper status, custom field
- TruST25 Digital Signature
- NFC Tap Incremental Counter 24-bit with anti-tearing
- Untraceable (by default possible) & Kill modes
- Tamper Detect pin for open / short detection (TD1/TD0)

#### 2.5.1.3 Key benefits

- Configurable User Memory Area
- Cloning Protection with Digital Signature (Cloud management)
- 60-year data retention, 100k cycles erase/write

#### 2.5.2 Tag 2: ST25TN

This board embeds a ST25TN (ST25TN01KAFH5 UDFPN5) with its tuned 10 x 5mm antenna.

Figure 14. ST25TN board

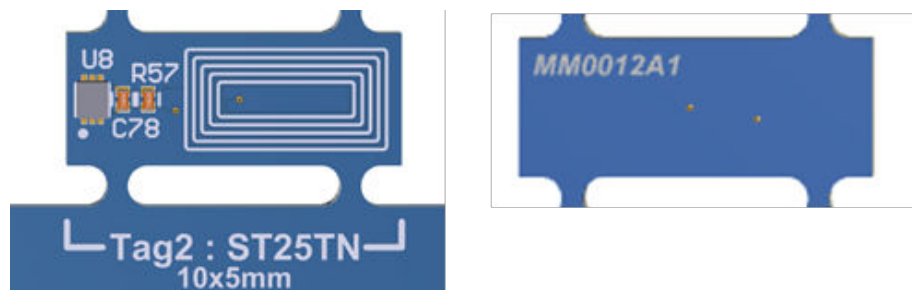

#### 2.5.2.1 Use cases

Product configuration, accessory recognition, smart poster, gaming, NFC consumer engagement, and NFC token.

#### 2.5.2.2 Key features

- ISO14443-A Type A and NFC type 2
- High speed operations (106kb/s)
- Augmented NDEF: UID, Read counter
- TruST25 digital signature
- Reader + Tag feature (implemented on Mercury reader)

### 2.5.2.3

#### **Key benefits**

- Tiny FPN5 package (1.7x1.4mm) – Low cost application
- 50pF internal RF tuning capacitor allowing small antenna design
- 60-year data retention, 100K cycles erase/write

## 3 Kit contents

### 3.1 Board naming

**Table 5. Board cross references**

Kit naming: STEVAL-25R200SA <sup>(1)</sup>			
Board naming: STEVAL-25R200A <sup>(2)</sup>		CP: STEVAL-25R200A	FG: STEVAL\$25R200AA
Quantity	Board or accessory ID	Name	Description
1	MM0003A1	STLink	STLink board delivered with STEVAL-25R200A.
1	MM0004A1	ST25R200 Module	MCU+ST25R200 board delivered with STEVAL-25R200A.
1	MM0005A1	Main NFC Antenna	Antenna main board delivered with STEVAL-25R200A.
1	MM0006A1	Dual Antenna Hub	Antenna Hub board delivered with STEVAL-25R200A.
1	MM0007A1	ANT1	Antenna hub ANT1 board delivered with STEVAL-25R200A.
1	MM0008A1	ANT2	Antenna Hub ANT2 board delivered with STEVAL-25R200A.
1	MM0009A1	Flexible antenna	Antenna Flex board delivered with STEVAL-25R200A.
1	MM0010A1	50-ohm antenna interface	Antenna 50-ohm board delivered with STEVAL-25R200A.
1	MM0011A1	Tag 1: ST25TV	ST25TV Tag board delivered with STEVAL-25R200A.
1	MM0012A1	Tag 2: ST25TN	ST25TN Tag board delivered with STEVAL-25R200A.
Board naming: STEVAL-FANTR1A <sup>(2)</sup>		CP: STEVAL-FANTR1A	FG: STEVAL\$FANTR1AA
Quantity	Board or accessory ID	Name	Description
1	MM0014A1	STEVAL-FANTR1A	Flex Antenna C7 12x12 in the STEVAL-25R200SA Kit
1	TT-ND201-01-A10L021	Adhesive Tag for ST25TN	(ST25TN01K-AFG5 ) > Talkin Things PN in the STEVAL-25R200SA Kit
1	TT-HD12-01-S1CL01	Adhesive Tag for ST25TV	(ST25TV512C-AFG9) > Talkin Things PN in the STEVAL-25R200SA Kit
3	ST25R200- UQFN24_4X4_0.5	ST25R200 in piece of real	ST25R200 3x parts in piece of real for tests in the STEVAL-25R200SA Kit

1. Including boards and accessories

2. Including breakable device

### 3.2 Naming location

Figure 15. STEVAL-25R200A top side

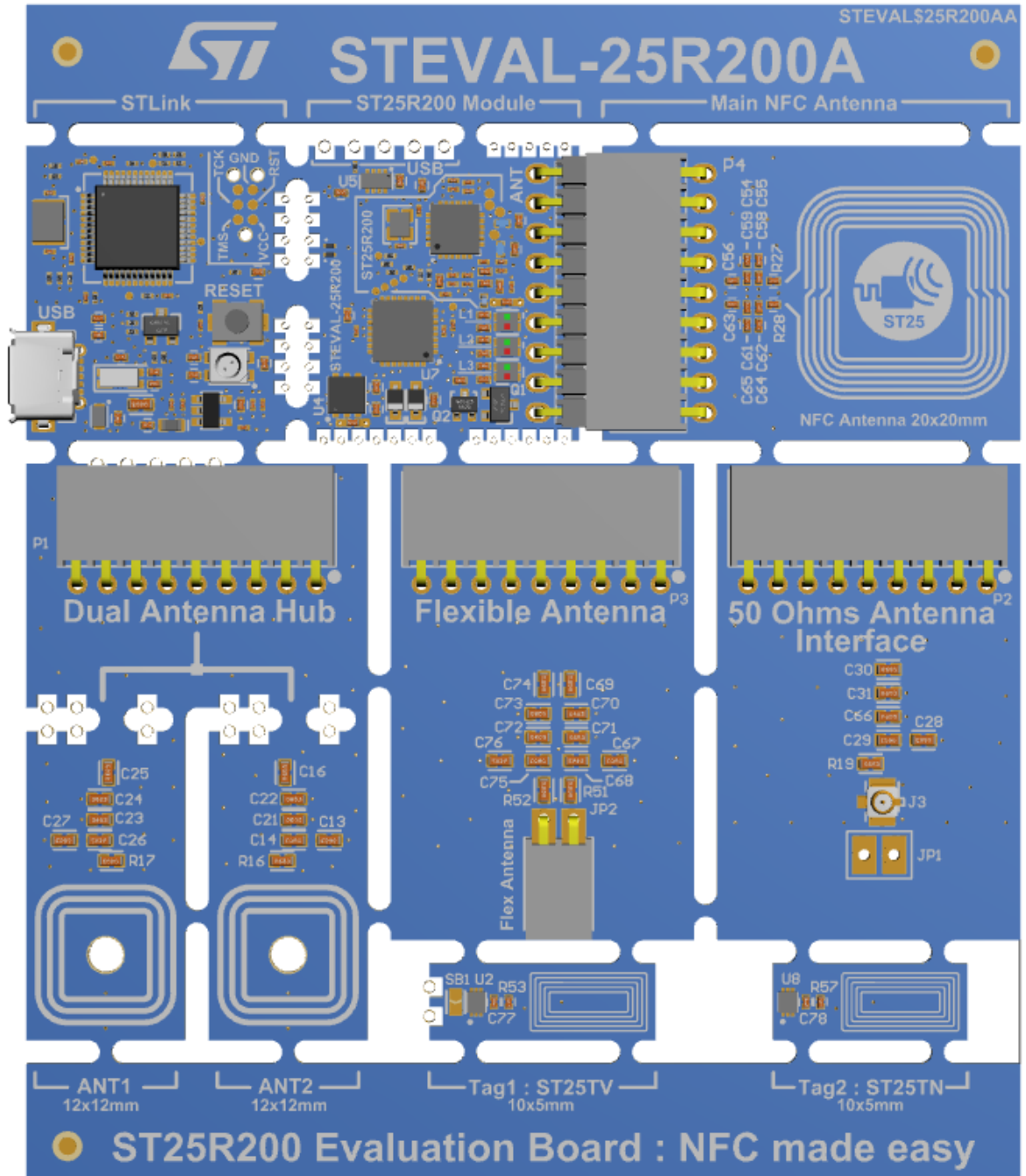
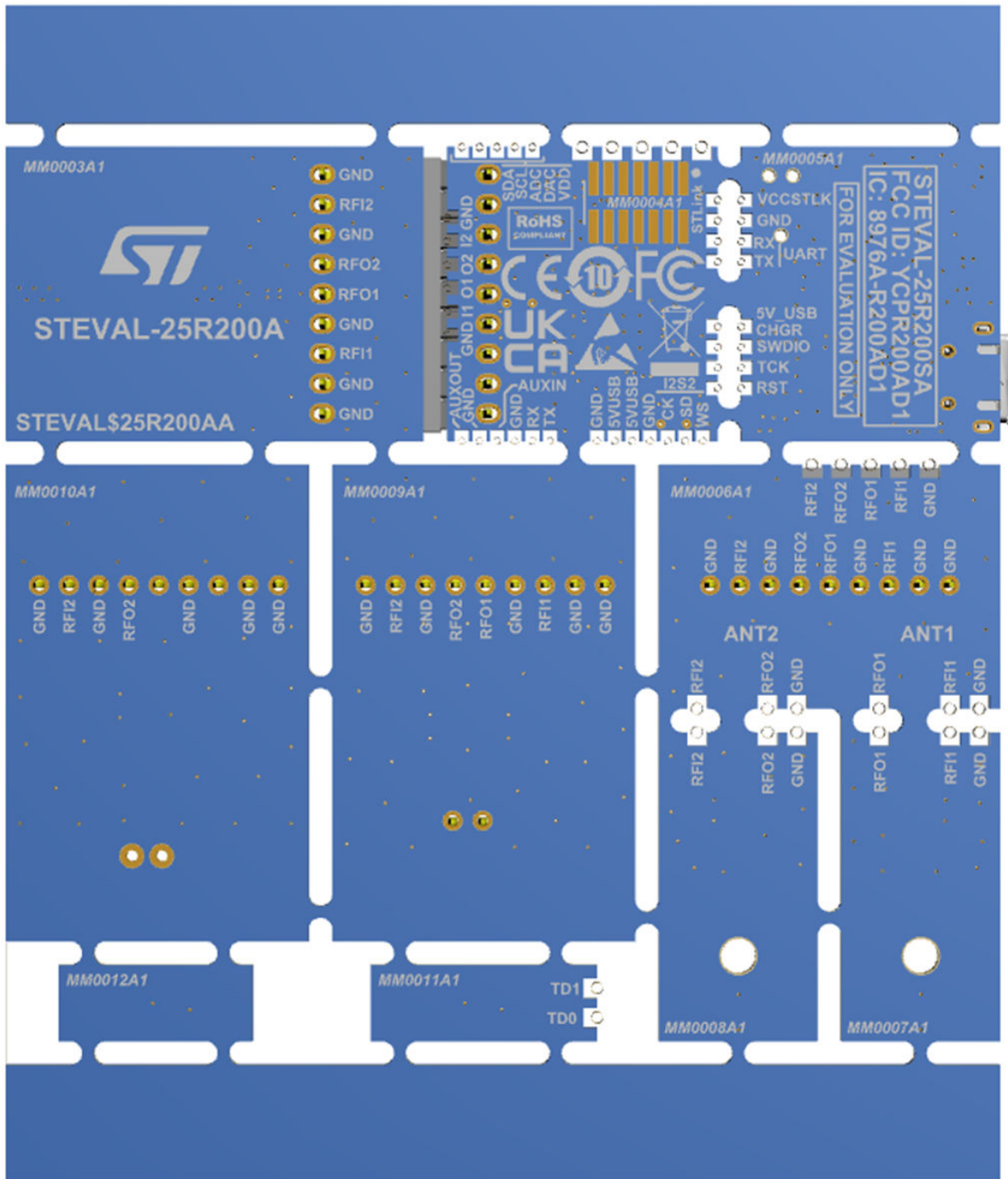

Figure 16. STEVAL-25R200A bottom side





## 4 Getting started

### 4.1 System requirements

- A USB port capable of delivering at least 400 mA at 5 V (2 W) (option 1)
- A safety extra-low voltage (SELV) limited power source to supply the unit through the USB port (option 2)
- A micro-USB cable to use the embedded ST-LINK and the STM32 ecosystem development

### 4.2 How to use the kit

**Step 1.** To control the board, download the STSW-ST25Rxxx software and install it.

**Step 2.** Connect the STEVAL-25R200A kit to a PC via a micro-USB cable (power option 2).

*Important:* It must be used on a clean and non-flammable surface. The PC USB port must be capable of delivering at least 250 mA at 5 V.

This allows demonstrating the ST25R200 features:

- Reader and writer
- USB mode (refer to the next section for further details).

Detailed usage / demo mode is explained in the software user manual for the STEVAL-25R200 board.

### 4.3 How to use the kit in standalone mode

**Step 1.** Power it through the micro-USB via a cable connected to the power source.

**Step 2.** Supply the unit through a safety extra-low voltage (SELV) limited power source via the USB port (power option 1).

The source must not exceed 60 VDC/8 A/100 V.

When powered up, the microcontroller starts the firmware which was previously defined and already downloaded in the flash memory. (see AN xxxx)

## 5 Schematic diagrams

Figure 17. STEVAL-25R200SA main board circuit schematic (1 of 7)

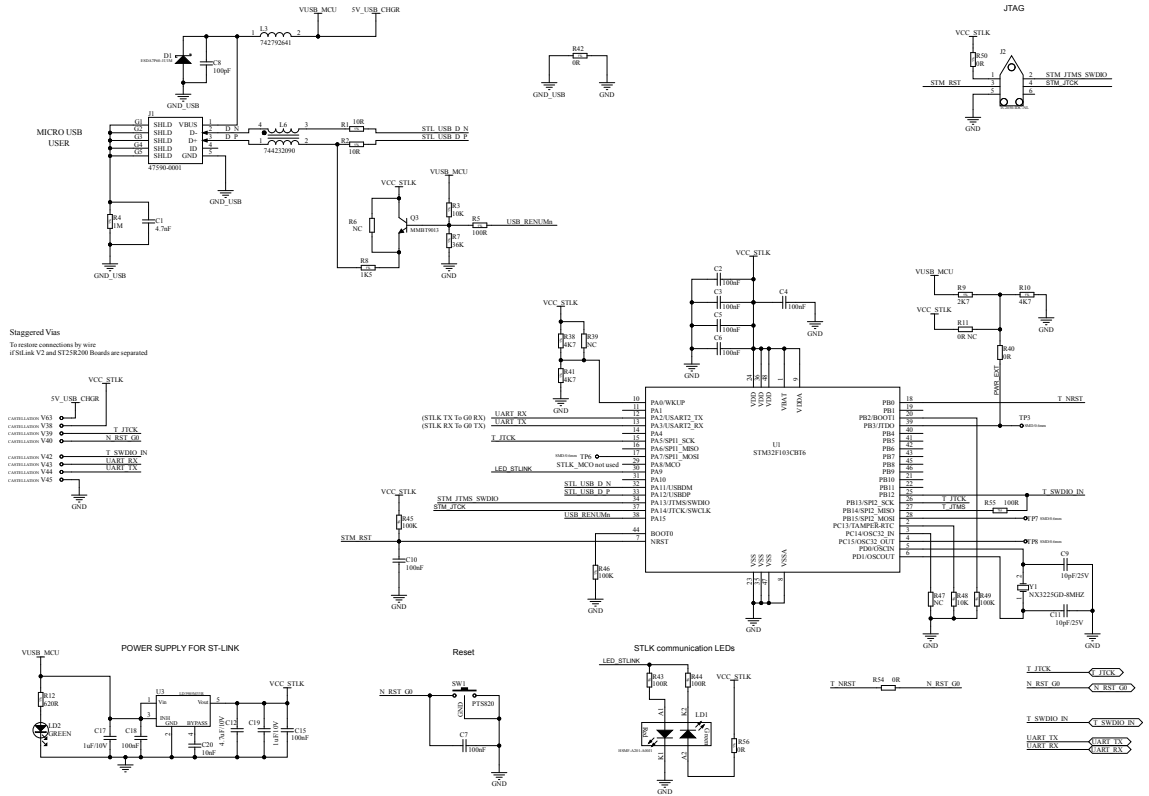

Figure 18. STEVAL-25R200SA main board circuit schematic (2 of 7)

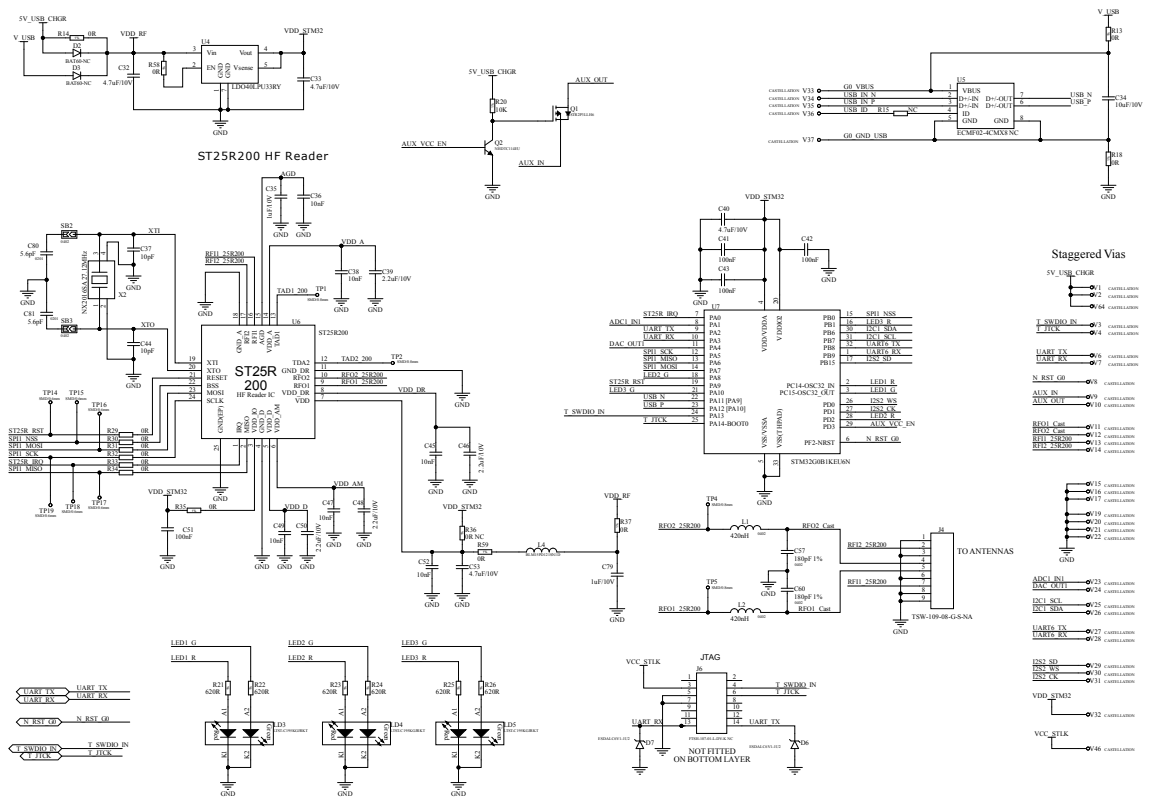

Figure 19. STEVAL-25R200SA main board circuit schematic (3 of 7)

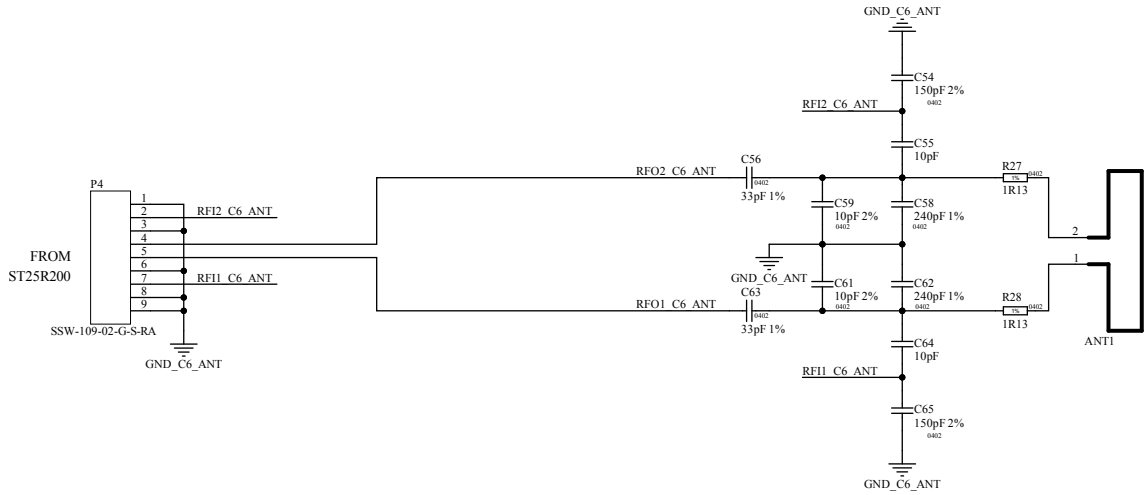

Figure 20. STEVAL-25R200SA main board circuit schematic (4 of 7)

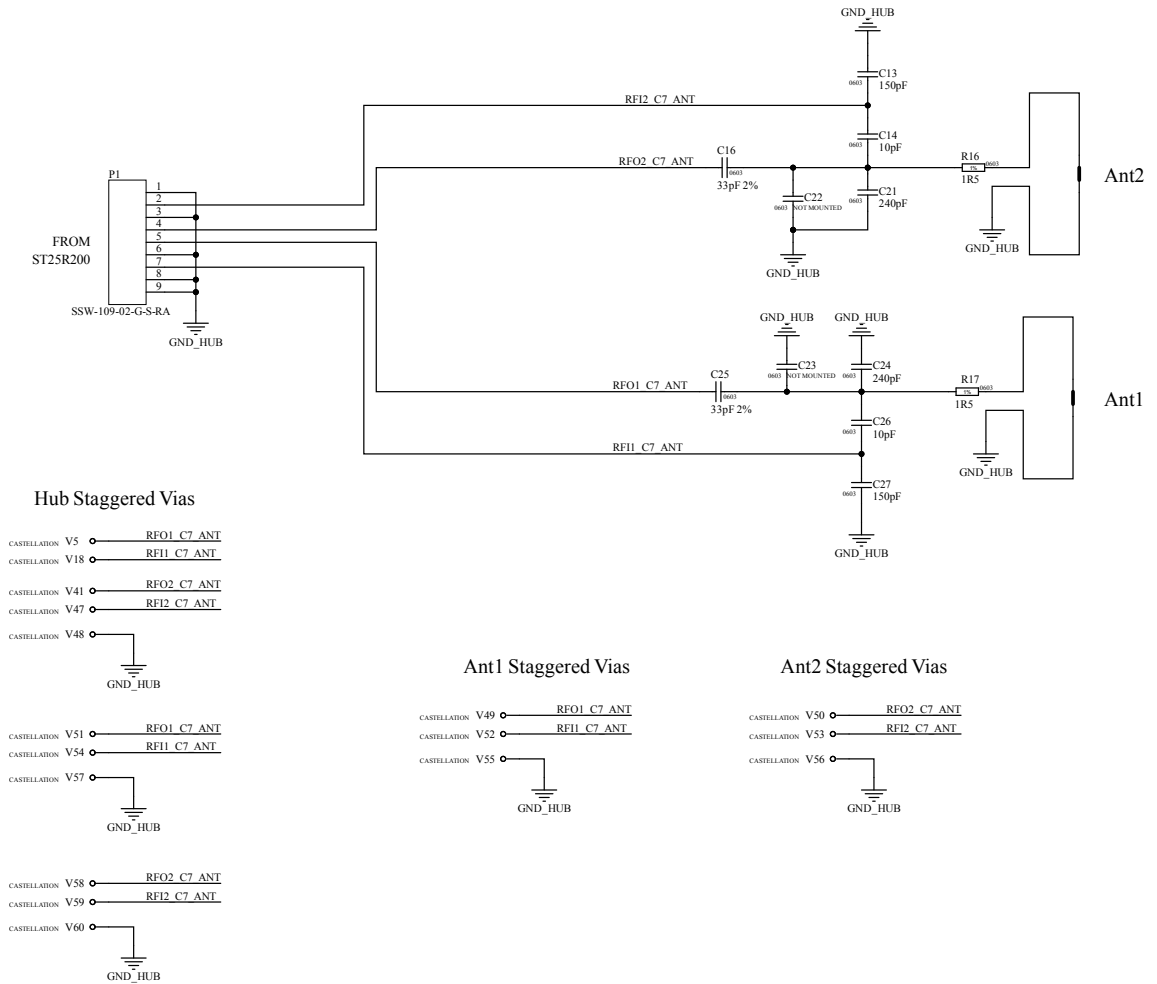

Figure 21. STEVAL-25R200SA main board circuit schematic (5 of 7)

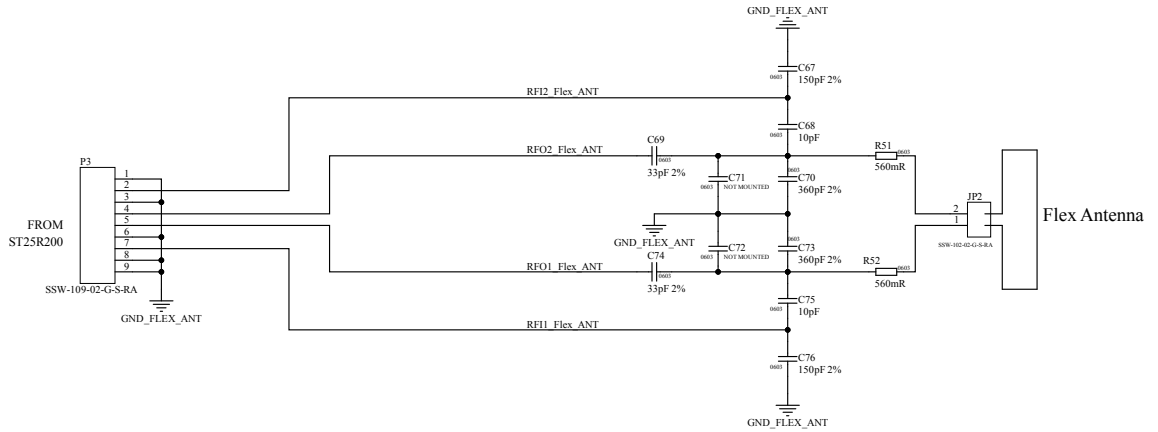

Figure 22. STEVAL-25R200SA main board circuit schematic (6 of 7)

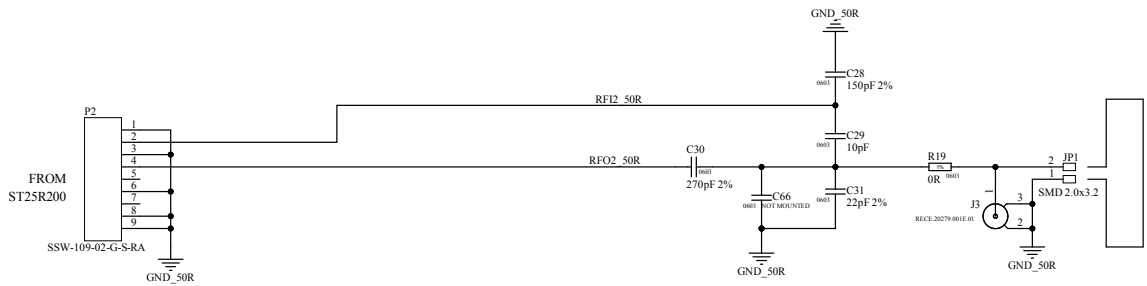
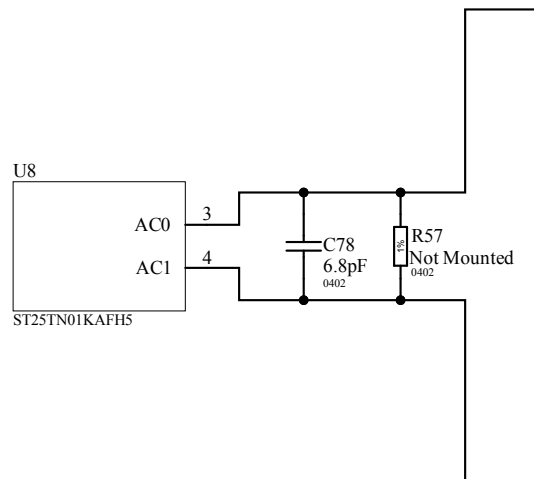
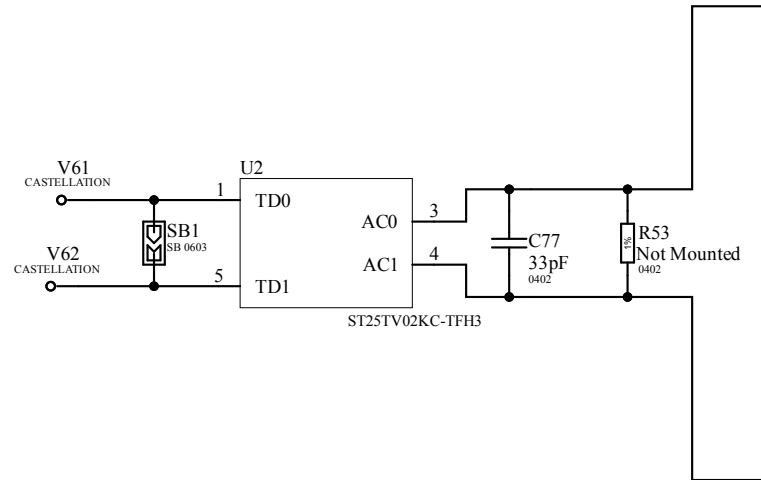

Figure 23. STEVAL-25R200SA main board circuit schematic (7 of 7)



## 6 Bill of materials

**Table 6. STEVAL-25R200SA bill of materials**

Item	Q.ty	Ref.	Part/value	Description	Manufacturer	Order code
1	1	A	Table 7. STEVAL-25R200A	NFC/RFID reader board based on the ST25R200 IC	ST	Not available for separate sale
2	1	B	STEVAL-FANTR1A	C7 12x12 Flex Antenna	ST	Not available for separate sale
3	1	C	ST25TN01K-AFG5	Adhesive Tag for ST25TN Provided by CS	ST	Not available for separate sale
4	1	D	ST25TV512C-AFG9	Adhesive Tag for ST25TV Provided by CS	ST	Not available for separate sale
5	1	E	ST25R200-UQFN24_4X4_0.5	SAMPLE OF ST25R200 in piece of reel	ST	Not available for separate sale
6	1	F	FIRMWARE	FIRMWARE of testing for STEVAL-R200	ST	Not available for separate sale

**Table 7. STEVAL-25R200A bill of materials**

Item	Q.ty	Ref.	Part/value	Description	Manufacturer	Order code
1	1	C1	4.7nF, 0402, 25V, +/-10%	Capacitor 0402 4.7nF 25V 10% X7R	MURATA	GRM155R71A473KA01D
2	13	C2, C3, C4, C5, C6, C7, C10, C15, C18, C41, C42, C43, C51	100nF, 0201, 10V, +/-10%	Capacitor 0201 100nF 10 V X7S 10%	MURATA	GRM033C71A104KE14D
3	1	C8	100pF, 0402, 50V, +/-5%	Capacitor 0402 100pF 50V 5% COG	MURATA	GCM1555C1H101JA16J
4	4	C9, C11, C37, C44	10pF, 0201, 50V, +/-1%	Capacitor 0201 10pF 25V C0G	MURATA	GCM0335C1H100FA16J
5	5	C12, C32, C33, C40, C53	4.7uF, 0402, 10V, +/-20%	Cap GRM155R61A475MEAA 4.7uF 10V 0402 20%	MURATA	GRM155R61A475MEAAD
6	5	C13, C27, C28, C67, C76	150pF, 0603, 50V, +/-2%	Capacitor 0603 150pF 50V 2% COG	MURATA	GRM1885C1H151GA01D
7	7	C14, C26, C29, C68, C71, C72, C75	10pF, 0603, 50V, +/-2%	Capacitor 0603 10pF 50V 5% C0G	MURATA	GRM1885C1H100GA01D

Item	Q.ty	Ref.	Part/value	Description	Manufacturer	Order code
8	4	C16, C25, C69, C74	33pF, 0603, 50V, +/- 2%	Capacitor 0603 33pF 50V 2% COG	MURATA	GRM1885C1H330GA01J
9	4	C17, C19, C35, C79	1uF, 0201, 10V, +/-20%	Cap GRM033R61A105ME15J 1uF 10V X5R 20% 0201	MURATA	GRM033R61A105ME15J
10	7	C20, C36, C38, C45, C47, C49, C52	10nF, 0201, 25V, +/-10%	Cap GRM033R61E103KA12D 10nF 0201 10% 25V	MURATA	GRM033R61E103KA12D
11	2	C21, C24	240pF, 0603, 50V, +/- 2%	Capacitor 0603 240pF 50V COG 2%	MURATA	GRM1885C1H241GA01J
12	2	C22, C23	18pF, 0603, 50V, +/- 2%	Capacitor 0603 18pF 50V 2% COG	MURATA	GQM1875C2E180FB12D
13	1	C30	270pF, 0603, 50V, +/-2%	Capacitor 0603 270pF 50V 2% COG	MURATA	GCM1885C2A271GA16J
14	1	C31	22pF, 0603, 50V, +/-2%	Capacitor 0603 22pF 50V 2% COG	MURATA	GCM1885C2A220FA16D
15	1	C34	10uF, 0402, 10V, +/-20%	Cap GRM155R61A106ME44D 10uF 10V X5R 0402	MURATA	GRM155R61A106ME11D
16	4	C39, C46, C48, C50	2.2uF, 0201, 10V, +/-10%	Capacitor GRM033R61A225ME47 2.2uF 10V 0201	MURATA	GRM033R61A225KE47J
17	2	C54, C65	150pF, 0402, 50V, +/-2%	Capacitor 0402 150pF 50V 2% COG	MURATA	GRM1555C2A151GE01J
18	2	C55, C64	10pF, 0402, 25V, +/- 5%	Capacitor 0402 10pF 25V 5% NPO	MURATA	GCM1555C1H100GA16D
19	2	C56, C63	33pF, 0402, 50V, +/-1%	Capacitor 0402 33pF 50V 1% COG	MURATA	GRM1555C1H330FA01D
20	4	C57, C60	180pF, 0402, 50V, +/- 1%	Capacitor 0402 180pF 50V 1% COG	MURATA	GCM1555C1H181FA16J
21	4	C58, C62	240pF, 0402, 50V, +/- 1%	Capacitor 0402 240pF 50V 1% COG	MURATA	GCM1555C1H241FA16D
22	2	C59, C61	10pF, 0402, 50V, +/-2%	Capacitor 0402 10pF 50V 2% COG	MURATA	GCM1555C1H100GA16D
23	1	C66	0603	Capacitor 0603 (not mounted)	N/A	N/A
24	2	C70, C73	360pF, 0603, 50V, +/- 2%	Capacitor 0603 360pF 50V COG 2%	MURATA	GRM1885C1H361GA01D
25	1	C77	33pF, 0402, 50V, +/- 2%	Capacitor 0402 33pF 50V 2% COG	MURATA	GRM1555C2A330GA01D
26	1	C78	6.8pF, 0402, 50V, +/-1%	Capacitor 0402 6.8pF 50V 1% COG	MURATA	GCM1555C1H6R8FA16D
27	2	C80, C81	5.6pF, 0201, 25V, +/- 0.5pF	Capacitor 0201 5.6pF 25V COG	MURATA	GRM0335C1E5R6DA01D
28	1	D1	1610-2PINS-A-K	Voltage suppressor ESDA7P60-1U1M	ST	ESDA7P60-1U1M
29	2	D2, D3	SOD323	DIODE BAT60JFILM (not mounted)	ST	BAT60JFILM

Item	Q.ty	Ref.	Part/value	Description	Manufacturer	Order code
30	2	D6, D7	0201	ESD PROTECT TRANSIL ESDALC6V1-1U2	ST	<a href="#">ESDALC6V1-1U2</a>
31	1	J1	MOLEX-47590-0001	47590-0001 - MICRO USB AB	MOLEX	47590-0001
32	1	J3	TAOGLAS- RECE.20279.001E.01	CONN RECE.20279.001E.01	TAOGLAS	RECE.20279.001E.01
33	1	J4	SAMTEC-TSW-1X9PTS- NA-STYLE-08	CONNECTOR TSW-109-08- G-S-NA	SAMTEC	TSW-109-08-G-S-NA
34	1	J6	SAMTEC-FTSH-107-01- X-DV-K	CONNECTOR FTSH-107-01- L-DV-K (not mounted)	SAMTEC	SSW-102-02-G-S-RA
35	1	JP2	SAMTEC-SSW-1X2PTS- RA-THROUGH-HOLE	CONNECTOR SSW-102-02- G-S-RA	SAMTEC	SSW-102-02-G-S-RA
36	2	L1, L2	420 nH, COILCRAFT- SELF-SERIE-0402DF 5%	Inductor 0402DF-421XJR 420nH	COILCRAFT	0402DF-421XJRW
37	1	L3	300 Ohms, 0603	742792641 EMI FERRITE BEAD 300 Ohms	WURTH ELEKTRONIK	742792641
38	1	L4	120 Ohms, 0402	SELF BLM15PD121SN1D 0402	MURATA	BLM15PD121SN1D
39	1	L6	90 Ohms ,WURTH-WE- CNSW-1206	744232090 COMMON MODE FILTER	WURTH ELEKTRONIK	744232090
40	1	LD1	LED-PACKAGE-PLCC-4, 2.2V	LED BICOLOR HSMF-A201- A00J1	BROADCOM	HSMF-A201-A00J1
41	1	LD2	0603	GREEN-YELLOW LED WURTH 150060VS86000	WURTH ELEKTRONIK	150060VS86000
42	3	LD3, LD4, LD5	0606	LED BICOLOR LTST- C195KGJRKT	LITE-ON	LTST-C195KGJRKT
43	4	P1, P2, P3, P4	SAMTEC-SSW-1X9PTS- RA-THROUGH-HOLE	CONNECTOR SSW-109-02- G-S-RA	SAMTEC	SSW-109-02-G-S-RA
44	1	Q1	SOT23-G-D-S	Transistor STR2P3LLH6 SOT23	ST	<a href="#">STR2P3LLH6</a>
45	1	Q2	SOT323-BCE	Transistor NHDTC114EU SOT323	NEXPERIA	NHDTTC114EU
46	1	Q3	SOT23-B-C-E	Transistor MMBT9013L-G- AE3 NPN	UNISONIC	MMBT9013
47	2	R1, R2	10 Ohms, 0402	Resistor 0402 10R 1% 62.5mW	YAGEO	AC0402FR-0710RL
48	2	R3, R48	10K, 0201	Resistor 0201 10K 1% 50 mW	YAGEO	RC0201FR-7D10KL
49	1	R4	1M, 0402	RESISTOR 0402 1M 1%	Würth Elektronik	560112110033
50	2	R5, R55	100 Ohms, 0201	Resistor 0201 100R 1%	YAGEO	AF0201FR-07100RL
51	4	R6, R15, R39, R47	0201	Resistor 0201 (not mounted)	N/A	N/A
52	1	R7	36K, 0201	Resistor 0201 36K 1% 50 mW	VISHAY	CRCW020136K0FKED
53	1	R8	1K5, 0201	Resistor 0201 1K5 1% 50mW	YAGEO	AC0201FR-071K5L
54	1	R9	2K7, 0201	RESISTOR 0201 2K7 1% 50mW	YAGEO	RC0201FR-072K7L



Item	Q.ty	Ref.	Part/value	Description	Manufacturer	Order code
55	3	R10, R38, R41	4K7, 0201	RESISTOR 0201 4K7 1% 50mW	YAGEO	RC0201FR-074K7L
56	1	R11	Ohm 0201	RESISTOR 0201 0R (not mounted)	YAGEO	RC0201FR-070RL
57	7	R12, R21, R22, R23, R24, R25, R26	620 Ohms, 0402	RESISTOR 0402 620R 1% 50 mW	Würth Elektronik	560112110265
58	10	R13, R14, R18, R35, R37, R42, R50, R56, R58, R59	0 Ohm, 0402	Resistor 0402 0R	YAGEO	AC0402FR-070RL
59	3	R16, R17	1.5 Ohm, 0603	RESISTOR 0603 1.5 Ohm 1%	YAGEO	AC0603FR-071R5L
60	3	R19	0 Ohm, 0603	RESISTOR 0603 0 Ohm	YAGEO	AC0603FR-070RL
61	1	R20	10K, 0402	RESISTOR 0402 10K 1%	VISHAY	CRCW040210K0FKEDC
62	2	R27, R28	1.13 Ohm, 0402	RESISTOR 0402 1.13 Ohm 1% 62.5mW	VISHAY	CRCW04021R13FKED
63	8	R29, R30, R31, R32, R33, R34, R40, R54	0 Ohm, 0201	RESISTOR 0201 0R 5%	YAGEO	RC0201JR-7D0RL
64	1	R36	0 Ohm, 0402	Resistor 0402 0R (not mounted)	YAGEO	AC0402FR-070RL
65	2	R43, R44	100 Ohms, 0402	RESISTOR 0402 100R 1%	VISHAY	CRCW0402100RFKEDC
66	3	R45, R46, R49	100K, 0201	Resistor 0201 100K 1%	YAGEO	RC0201FR-7D100KL
67	2	R51, R52	560 mOhm, 0603	Resistor 0603 560MilliOhm 1%	YAGEO	RL0603FR-070R56L
68	2	R53, R57	0402	RESISTOR 0402 (not mounted)	N/A	N/A
69	1	SB1	0603, STRAP-FORMAT-0603-OUVERT	SOLDER BRIDGE OPEN SIZE 0603	N/A	N/A
70	2	SB2, SB3	0402, STRAP-FORMAT-0402-OUVERT	SOLDER BRIDGE OPEN SIZE 0402	N/A	N/A
71	1	SW1	C&K-INTER-SERIE-PTS820-WITHOUT-PEGS-H=2.0	PUSH BUTTON PTS820-J20M-SMTR-LFS	C&K	PTS820-J20M-SMTR-LFS
72	1	U1	LQFP48	IC STM32F103CBT6 LQFP48	ST	<a href="#">STM32F103CBT6</a>

Item	Q.ty	Ref.	Part/value	Description	Manufacturer	Order code
73	1	U2	UFDFPN5	NFC TAG IC ST25TV02KC-TFH3 UFDFPN5	ST	<a href="#">ST25TV02KC-TFH3</a>
74	1	U3	SOT23-5PINS	LDO LD3985M33R SOT23-5	ST	<a href="#">LD3985M33R</a>
75	1	U4	DFN6-3x3	LDO LDO40LPU33RY DFN6	ST	<a href="#">LDO40LPU33RY</a>
76	1	U5	QFN-8L	ESD PROTECTION ECMF02-4CMX8 (not mounted)	N/A	N/A
77	1	U6	QFN24	HF READER ST25R200-BMET QFN24	ST	<a href="#">ST25R200-BMET</a>
78	1	U7	UFQFPN32	MCU STM32G0B1KEU6N UFQFPN32	ST	<a href="#">STM32G0B1KEU6N</a>
79	1	U8	UFDFPN5	NFC TAG IC ST25TN01K-AFH5 UFDFPN5	ST	<a href="#">ST25TN01K-AFH5</a>
80	1	X2	NDK-NX2016SA	CRYSTAL NX2016SA-27.12MHZ-EXS00A-CS01188 NDK	NDK AMERICA	<a href="#">NX2016SA-27.12MHZ-EXS00A-CS01188</a>
81	1	Y1	NDK-NX3225GD	SMD CRYSTAL NX3225GD-8MHZ-EXS00A-CG04874	NDK AMERICA	<a href="#">NX3225GD-8MHZ-STD</a>

## 7 Kit versions

**Table 8. STEVAL-25R200SA versions**

PCB version	Schematic diagrams	Bill of materials
STEVAL\$25R200SAA <sup>(1)</sup>	STEVAL\$25R200SAA schematic diagrams	STEVAL\$25R200SAA bill of materials

1. This code identifies the STEVAL-25R200SA evaluation kit first version. The kit consists of a STEVAL-25R200A whose version is identified by the code STEVAL\$25R200AA and a STEVAL-FANTR1A whose version is identified by the code STEVAL\$FANTR1AA.

## 8 Regulatory compliance information

*Note:* The evaluation kit with order code STEVAL-25R200SA contains the main board STEVAL\$25R200AA plus the flexible antenna board STEVAL\$FANTR1AA.

FCC certified, with FCC ID: YCPR200AD1

IC certified, with IC: 8976A-R200AD1; PMN: STEVAL-25R200SA; HVIN: STEVAL-25R200SA

### Notice for US Federal Communication Commission (FCC)

STEVAL-25R200SA

Part 15.19

This device complies with part 15 of the FCC Rules. Operation is subject to the following two conditions:

(1) This device may not cause harmful interference, and (2) this device must accept any interference received, including interference that may cause undesired operation.

Part 15.21

Any changes or modifications to this equipment not expressly approved by STMicroelectronics may cause harmful interference and void the user's authority to operate this equipment.

Part 15.105

This equipment has been tested and found to comply with the limits for a Class B digital device, pursuant to part 15 of the FCC Rules. These limits are designed to provide reasonable protection against harmful interference in a residential installation. This equipment generates, uses and can radiate radio frequency energy and, if not installed and used in accordance with the instructions, may cause harmful interference to radio communications. However, there is no guarantee that interference will not occur in a particular installation. If this equipment does cause harmful interference to radio or television reception, which can be determined by turning the equipment off and on, the user is encouraged to try to correct the interference by one or more of the following measures:

- Reorient or relocate the receiving antenna.
- Increase the separation between the equipment and receiver.
- Connect the equipment into an outlet on a circuit different from that to which the receiver is connected.
- Consult the dealer or an experienced radio/TV technician for help.

### Notice for Innovation, Science and Economic Development Canada (ISED)

This device contains licence-exempt transmitter(s)/receiver(s) that comply with Innovation, Science and Economic Development Canada's licence exempt RSS(s). Operation is subject to the following two conditions: (1) This device may not cause interference. (2) This device must accept any interference, including interference that may cause undesired operation of the device. Changes or modifications not expressly approved by the party responsible for compliance could void the user's authority to operate the equipment.

This class B device complies with Canadian Interference-Causing Equipment Standard ICES-003: CAN ICES-003(B) / NMB-003(B)

### Conformité à Innovation, Sciences et Développement Économique Canada (ISDE)

L'émetteur/recepteur exempt de licence contenu dans le présent appareil est conforme aux CNR d'Innovation, Sciences et Développement économique Canada applicables aux appareils radio exempts de licence. L'exploitation est autorisée aux deux conditions suivantes: (1) L'appareil ne doit pas produire de brouillage; (2) L'appareil doit accepter tout brouillage radioélectrique subi, même si le brouillage est susceptible d'en compromettre le fonctionnement. Les changements ou modifications non expressément approuvés par la partie responsable de la conformité pourraient annuler l'autorité de l'utilisateur à faire fonctionner l'équipement.

Cet appareil numérique de classe B est conforme à la Norme sur le Matériel Brouilleur NMB-003 du Canada: CAN ICES-003(B) / NMB-003(B)

### Notice for the European Union

The kit STEVAL-25R200SA is in conformity with the essential requirements of the Directive 2014/53/EU (RED) and of the Directive 2015/863/EU (RoHS). Applied harmonized standards are listed in the EU Declaration of Conformity.

**Notice for the United Kingdom**

The kit STEVAL-25R200SA is in compliance with the UK Radio Equipment Regulations 2017 (UK SI 2017 No. 1206 and amendments) and with the Restriction of the Use of Certain Hazardous Substances in Electrical and Electronic Equipment Regulations 2012 (UK SI 2012 No. 3032 and amendments). Applied standards are listed in the UK Declaration of Conformity.

## Revision history

**Table 9. Document revision history**

Date	Version	Changes
30-Sep-2024	1	Initial release.
27-Nov-2024	2	Updated <a href="#">Section 3.1: Board naming</a> and <a href="#">Section 7: Kit versions</a> .

## Contents

<b>1</b>	<b>Features</b>	<b>3</b>
<b>2</b>	<b>Hardware overview</b>	<b>4</b>
2.1	STEVAL-25R200SA kit usage	4
2.1.1	Kit content	4
2.1.2	Option	4
2.1.3	kit usage overview	4
2.2	The core system	5
2.2.1	Core system boards	5
2.2.2	STLink board	5
2.2.3	ST25R200 module	6
2.2.4	Main NFC antenna	9
2.3	Complementary antennas	9
2.3.1	Dual antenna hub	9
2.3.2	Flexible antenna	10
2.3.3	50-ohm antenna	10
2.4	Antenna tuning	11
2.5	NFC tags	11
2.5.1	Tag 1: ST25TV	11
2.5.2	Tag 2: ST25TN	12
<b>3</b>	<b>Kit contents</b>	<b>14</b>
3.1	Board naming	14
3.2	Naming location	15
<b>4</b>	<b>Getting started</b>	<b>17</b>
4.1	System requirements	17
4.2	How to use the kit	17
4.3	How to use the kit in standalone mode	17
<b>5</b>	<b>Schematic diagrams</b>	<b>18</b>
<b>6</b>	<b>Bill of materials</b>	<b>22</b>
<b>7</b>	<b>Kit versions</b>	<b>27</b>
<b>8</b>	<b>Regulatory compliance information</b>	<b>28</b>
	<b>Revision history</b>	<b>30</b>

## List of figures

<b>Figure 1.</b>	STEVAL-25R200A top side . . . . .	2
<b>Figure 2.</b>	STEVAL-25R200SA composition . . . . .	4
<b>Figure 3.</b>	Core system boards . . . . .	5
<b>Figure 4.</b>	STLink top and bottom side . . . . .	5
<b>Figure 5.</b>	ST25R200 module top and bottom side . . . . .	6
<b>Figure 6.</b>	Optional USB . . . . .	8
<b>Figure 7.</b>	STLink V3 connector . . . . .	8
<b>Figure 8.</b>	Main NFC antenna . . . . .	9
<b>Figure 9.</b>	STEVAL-25R200 reader RF path repartition . . . . .	9
<b>Figure 10.</b>	Dual antenna hub . . . . .	10
<b>Figure 11.</b>	Flexible antenna . . . . .	10
<b>Figure 12.</b>	50-ohm antenna . . . . .	11
<b>Figure 13.</b>	ST25TV board . . . . .	12
<b>Figure 14.</b>	ST25TN board . . . . .	12
<b>Figure 15.</b>	STEVAL-25R200A top side . . . . .	15
<b>Figure 16.</b>	STEVAL-25R200A bottom side . . . . .	16
<b>Figure 17.</b>	STEVAL-25R200SA main board circuit schematic (1 of 7) . . . . .	18
<b>Figure 18.</b>	STEVAL-25R200SA main board circuit schematic (2 of 7) . . . . .	18
<b>Figure 19.</b>	STEVAL-25R200SA main board circuit schematic (3 of 7) . . . . .	19
<b>Figure 20.</b>	STEVAL-25R200SA main board circuit schematic (4 of 7) . . . . .	19
<b>Figure 21.</b>	STEVAL-25R200SA main board circuit schematic (5 of 7) . . . . .	20
<b>Figure 22.</b>	STEVAL-25R200SA main board circuit schematic (6 of 7) . . . . .	20
<b>Figure 23.</b>	STEVAL-25R200SA main board circuit schematic (7 of 7) . . . . .	21



## List of tables

<b>Table 1.</b>	RF connector . . . . .	6
<b>Table 2.</b>	List of PCB pads . . . . .	7
<b>Table 3.</b>	Board powering . . . . .	7
<b>Table 4.</b>	STLink to ST25R200 module . . . . .	7
<b>Table 5.</b>	Board cross references . . . . .	14
<b>Table 6.</b>	STEVAL-25R200SA bill of materials . . . . .	22
<b>Table 7.</b>	STEVAL-25R200A bill of materials . . . . .	22
<b>Table 8.</b>	STEVAL-25R200SA versions . . . . .	27
<b>Table 9.</b>	Document revision history . . . . .	30

**IMPORTANT NOTICE – READ CAREFULLY**

STMicroelectronics NV and its subsidiaries (“ST”) reserve the right to make changes, corrections, enhancements, modifications, and improvements to ST products and/or to this document at any time without notice. Purchasers should obtain the latest relevant information on ST products before placing orders. ST products are sold pursuant to ST’s terms and conditions of sale in place at the time of order acknowledgment.

Purchasers are solely responsible for the choice, selection, and use of ST products and ST assumes no liability for application assistance or the design of purchasers’ products.

No license, express or implied, to any intellectual property right is granted by ST herein.

Resale of ST products with provisions different from the information set forth herein shall void any warranty granted by ST for such product.

ST and the ST logo are trademarks of ST. For additional information about ST trademarks, refer to [www.st.com/trademarks](http://www.st.com/trademarks). All other product or service names are the property of their respective owners.

Information in this document supersedes and replaces information previously supplied in any prior versions of this document.

© 2024 STMicroelectronics – All rights reserved