

## HU3PAK package mounting and thermal behavior

### Introduction

HU3PAK is a package made by STMicroelectronics ready for automotive and industrial high-performance applications. This package is a top side-cooling package. It can be mount over a PCB (Printed Circuit Board) and semiconductor chips are directly connected to the lead frame.

The behavior of a semiconductor device depends on the temperature of its silicon chip. This is the reason why electrical parameters are given at a specified temperature. To sustain the performance of a component and to avoid failure, the temperature must be limited by managing the heat transfer between the chip and the ambient atmosphere. The aim of this technical note is to provide guidelines for package mounting, handling and soldering, as well as thermal considerations linked to heat sink types and assembly methods.

HU3PAK is designed to be surface mounted on printed circuit board, and having its top side connected to external heat sink, to optimize thermal performance and allow maximum possible power to go through the device.



Figure 1. HU3PAK package overview

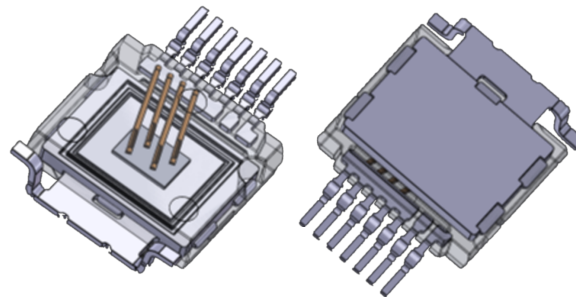

GADG070920211323SA

# 1 Package information

## 1.1 Package dimensions and packing

HU3PAK has the following dimensions:

Figure 2. HU3PAK package outline

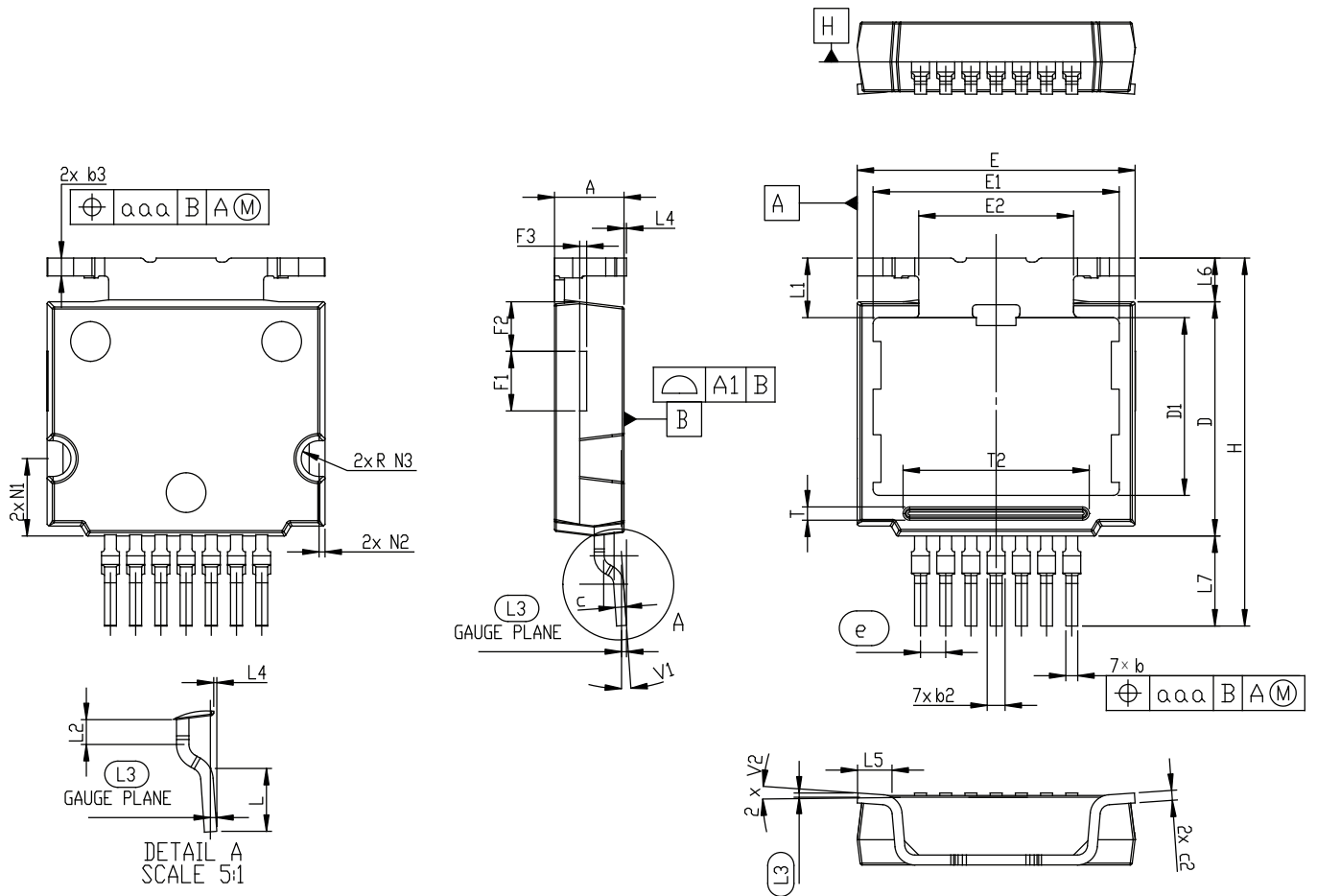

DM00674007\_2

**Table 1. HU3PAK package mechanical data**

Ref.	Dimensions		
	mm		
	Min.	Typ.	Max.
A	3.40	3.50	3.60
A1		0.05	
b	0.50	0.60	0.70
b2	0.50	0.70	1.00
b3	0.80	0.90	1.00
c	0.40	0.50	0.60
c2	0.40	0.50	0.60
D	11.70	11.80	11.90
D1	8.80	8.955	9.10
E	13.90	14.00	14.10
E1	12.30	12.40	12.50
E2	7.75	7.80	7.85
e		1.27	
H	18.00	18.58	19.00
aaa		0.10	
L	2.40	2.52	2.60
L1		3.05	
L2	0.90	1.00	1.10
L3		0.26	
L4	0.075	0.125	0.175
L5	1.83	1.93	2.03
L6	2.14	2.24	2.34
L7	4.44	4.54	4.64
F1	2.90	3.00	3.10
F2	2.40	2.50	2.60
F3	0.25	0.35	0.45
N1	3.80	3.90	4.00
N2	0.25	0.30	0.45
N3	0.80	0.90	1.00
T	0.50	0.67	0.70
T2	9.18	9.38	9.43
V1		0 °	8 °
V2		0 °	8 °

HU3PAK products are available in tape and reel packing, with 600 units per reel (13-inch reel, reel width 32 mm, pitch between pocket 20 ±0.1 mm).

Figure 3. HU3PAK in carrier tape

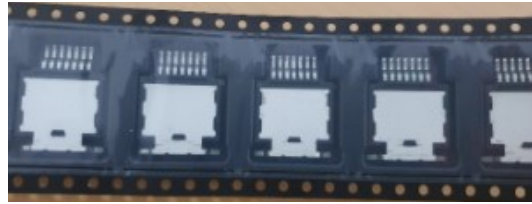

GADG070920211327SA

## 1.2 Moisture sensitivity

HU3PAK is not a package sensitive to moisture. Thus, it does not require dry packing.

The most commonly applied standard IPC/JEDEC J-STD-020E defines MSL level, as shown in figure here below.

Figure 4. Moisture sensitivity levels

LEVEL	FLOOR LIFE <sup>4</sup>		SOAK REQUIREMENTS <sup>3</sup>				
			STANDARD		ACCELERATED EQUIVALENT <sup>1</sup>		
					eV 0.40-0.48	eV 0.30-0.39	CONDITION
TIME	CONDITION	TIME (hours)	CONDITION	TIME (hours)	TIME (hours)	CONDITION	
1	Unlimited	≤30 °C/85% RH	168 +5/-0	85 °C/85% RH	NA	NA	NA
2	1 year	≤30 °C/60% RH	168 +5/-0	85 °C/60% RH	NA	NA	NA
2a	4 weeks	≤30 °C/60% RH	696 <sup>2</sup> +5/-0	30 °C/60% RH	120 +1/-0	168 +1/-0	60 °C/60% RH
3	168 hours	≤30 °C/60% RH	192 <sup>2</sup> +5/-0	30 °C/60% RH	40 +1/-0	52 +1/-0	60 °C/60% RH
4	72 hours	≤30 °C/60% RH	96 <sup>2</sup> +2/-0	30 °C/60% RH	20 +0.5/-0	24 +0.5/-0	60 °C/60% RH
5	48 hours	≤30 °C/60% RH	72 <sup>2</sup> +2/-0	30 °C/60% RH	15 +0.5/-0	20 +0.5/-0	60 °C/60% RH
5a	24 hours	≤30 °C/60% RH	48 <sup>2</sup> +2/-0	30 °C/60% RH	10 +0.5/-0	13 +0.5/-0	60 °C/60% RH
6	Time on Label (TOL)	≤30 °C/60% RH	TOL	30 °C/60% RH	NA	NA	NA

GADG070920211424SA

HU3PAK products are classified MSL level 1, therefore no time limit for storage is defined. Please refer to IPC/JEDEC J-STD-033 for details. Please note that baking a package too often this can cause solderability problems due to oxidation and/or intermetallic growth.

## 1.3 Component solderability

The leads of HU3PAK are plated with pure tin (10 µm minimum sn plating), which is ensuring a good solderability on PCB pad openings, even after a long storage time.

Tin plating performed is compatible with pb-containing and pb-free soldering processes.

## 2 Printed circuit board assembly

HU3PAK is a surface mount package. Assembly on PCB is composed of following process steps:

1. Solder pastes printing.
2. Component placement on PCB.
3. Reflow soldering.
4. Cleaning (optional).
5. Final solder-joint inspection.

### 2.1 Printed circuit board recommendations

#### 2.1.1 Material

There are no specific requirements related to PCB material for an HU3PAK package. STMicroelectronics performed evaluations with PCB using FR4 material, as it is a commonly used material. Regarding PCB thickness, as for thermal considerations (which is detailed in next chapters of this document), it is required to attach a heat sink at the top of the package. The thickness of the PCB of 1.6 mm or above, may be interesting to ease heat sink attachment, as it increases PCB stiffness.

#### 2.1.2 Copper

STMicroelectronics performed evaluations with 70  $\mu\text{m}$  (2Oz/ft<sup>2</sup>) base copper thickness on both sides of PCB to accommodate the high currents required by the application. This usually provides final copper thickness of around 75  $\mu\text{m}$ .

#### 2.1.3 PCB pad design

There are two different types of PCB pad configurations commonly used for surface mount packages:

- Non-solder mask defined (NSMD)
- Solder mask defined (SMD)

As their title describe, NSMD contact pads have the solder mask pulled away from the solderable metallization, while the SMD pads have the solder mask over the edge of the metallization, as shown in figure here below.

With the SMD pads, the solder mask restricts the flow of solder paste to the top of the metallization by preventing solder from flowing down along of the metal pad. This is different from the NSMD pads where the solder is flow around both the top and the sides of the metallization.

**Figure 5. Solder mask design**

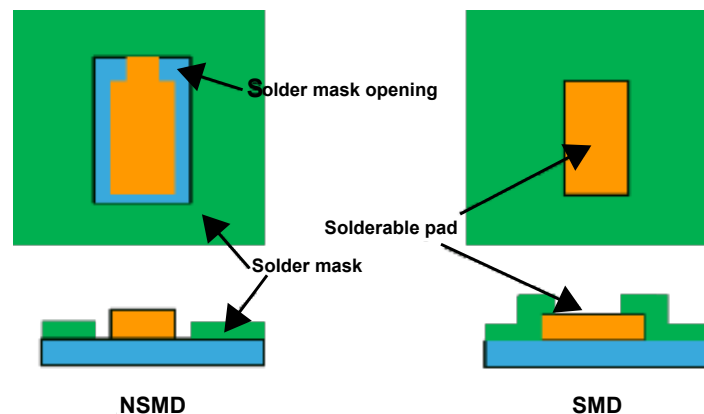

GADG021120211323SA

Typically, the NSMD pads are preferred since defining the location and size of the copper pad is easier to control than the solder mask. This is based on the fact that the copper etching process is capable of tighter tolerance than the solder-masking process.

For NSMD, solder mask openings should be larger than the copper pads by typically 80  $\mu\text{m}$  (radius).

#### 2.1.4 PCB solderable metallization

Solder pads must be easy for the solder paste to wet. In general, all finishes are well proven for surface mount technology assembly.

From a package point of view, it is difficult to recommend a certain PCB pad finish, that always meets all requirements. The choice of finish also depends on:

- The design of the board
- The geometry of the pad
- The various components mounted on the board
- The process conditions

It should be chosen according to the specific needs of the customer.

STMicroelectronics usually recommends two PCB finishing types. In both cases, the plating must be uniform, conforming, and free of impurities, in order to ensure a consistent solderability.

The first metallization finish consists of an organic preservative (OSP) coating on top of the copper pad. The organic coating assists in reducing oxidation to preserve the copper metallization for soldering.

The second metallization is NiAu (commonly electroless-plated nickel over the copper pad, followed by immersion gold). The thickness of the nickel layer is determined by the allowable internal material stresses and the temperature excursions the board is subjected to throughout its lifetime. In case of immersion gold process, the gold thickness is self-limited, but in any case, gold thickness should be thick enough to prevent Ni oxidation (typically above 0.05  $\mu\text{m}$ ) and thin enough to represent more than 5% of the overall solder volume. Having excessive gold in the solder joint can create gold embitterment, which may affect the reliability of the solder joint.

#### 2.1.5 Footprint

STMicroelectronics recommends footprint (see [Figure 6. HU3PAK recommended footprint \(dimensions in mm\)](#)) to achieve a correct soldering.

If possible, like any PCB design, it is recommended to keep a good balance between the top and bottom layers copper ratios to minimize PCB warpage, which may generate stress in the solder joints.

It should be noted that unlike other SMD power packages, which have a thermal pad soldered onto the PCB, the HU3PAK has a thermal pad facing upward to accept a heat sink. Consequently, PCB traces design has almost no influence on the thermal performance of the application, as the amount of heat that is transferred across the components leads is negligible compared to the heat flow through the heat sink.

Figure 6. HU3PAK recommended footprint (dimensions in mm)

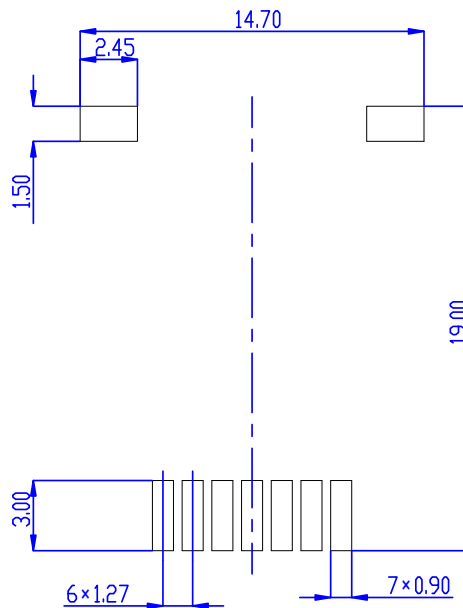

GADG041120211019SA

Figure 7. HU3PAK sample mounted on test PCB

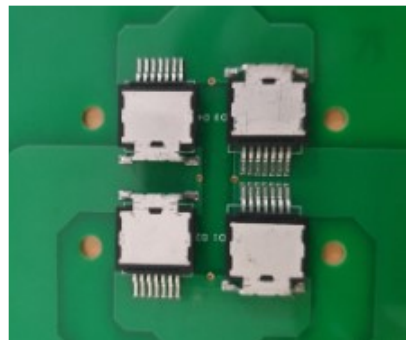

GADG080920210745SA

## 2.2 Screen printing stencil

Stencil screening the solder on the PCB is commonly used in the industry. A stainless steel stencil should be used with a thickness of 150  $\mu\text{m}$  to allow sufficient paste volume. To ensure a safe and repeatable stencil printing process, some generic design rules for stencil design should be followed (aspect ratio between opening and stencil thickness should be  $>1.5 \mu\text{m}$  for example), but are not described here as no issues may be expected due to important pads dimensions.

We recommend stencil opening to footprint ratio of 90%, as shown on recommended footprint here below (stencil opening are drawn in blue-dotted lines, while PCB solderable pad is in black lines).

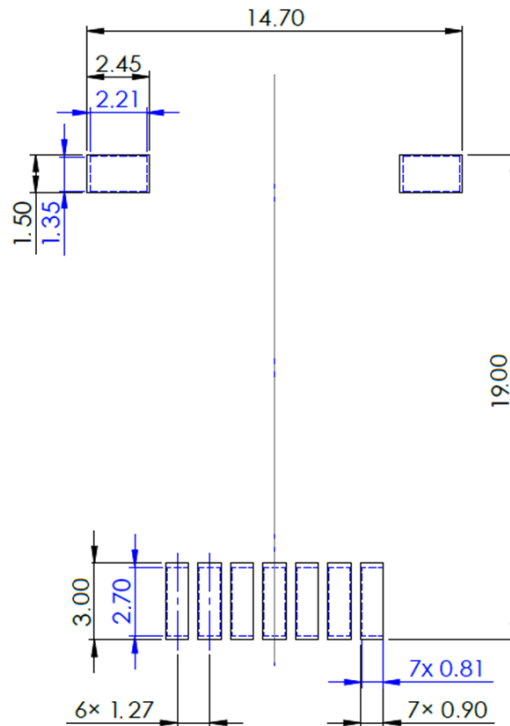
**Figure 8. Stencil opening recommendation**

GADG041120211240SA

The sidewalls of the stencil openings may be tapered approximately 5° to ease the release of the paste when the stencil mask is removed from PCB.

### 2.3 Solder paste

We recommend using solder paste with fine particles (type 3 or 4, meaning particle dimensions from 20 to 45  $\mu\text{m}$ ), as well as solder paste containing halide-free flux ROL0 according to ANSI/J-STD-004.

Higher paste types (finer) can be used if needed to mount much smaller packages on the same PCB.

For lead-free solders Sn-Ag-Cu, any Sn-Ag-Cu alloy with 1 to 4% Ag and <1% Cu should be convenient.

STMicroelectronics used Sn-Ag-Cu 0.5 for its evaluations (LOCTITE LF318 97SCAG88.5 BU, no clean, Pb free solder paste).

### 2.4 Placement

Manual placement should be avoided, as the device must be placed parallel to the PCB surface in order not to squeeze the solder paste on one side.

The weight of the device alone is sufficient to ensure a good contact with solder paste. So, there are no minimum placement force requirements.

The typical positioning accuracy of pick and place machines is  $\pm 50 \mu\text{m}$ , more than enough for this package (in addition, the self-aligning effect due to the surface tension of the liquid solder will ensure the self-centering of the package).

If components must be placed on both PCB sides, the side with HU3PAK must be processed last, as wetting forces could not hold the HU3PAK package during a second reflow.



## 2.5 Reflow profile

Forced convection oven is the preferred method for reflow.

The soldering process causes large thermal stress to a semiconductor component. This has to be minimized to assure a reliable and extended lifetime of the device.

The package is following IPC/JEDEC J-STD-020E requirements, and thus can be exposed to a maximum temperature of 245 °C for 10 seconds. Overheating during the reflow-soldering process may damage the device, therefore any solder temperature profile should be within these limits. As reflow techniques are most common in surface mounting, typical leadfree solder heating profiles (ST ECOPACK) are given here below for mounting on an FR4 PCB.

Please refer to the IPC/JEDEC J-STD-020E standard for further information about “large” components definition.

Note: Soldering profile defined in IPC/JEDEC J-STD-020E standard is used for reliability assessment and typically describe warmest profiles used for components mounting, not the necessary temperatures to achieve good soldering.

**Figure 9. Recommended soldering reflow profile**

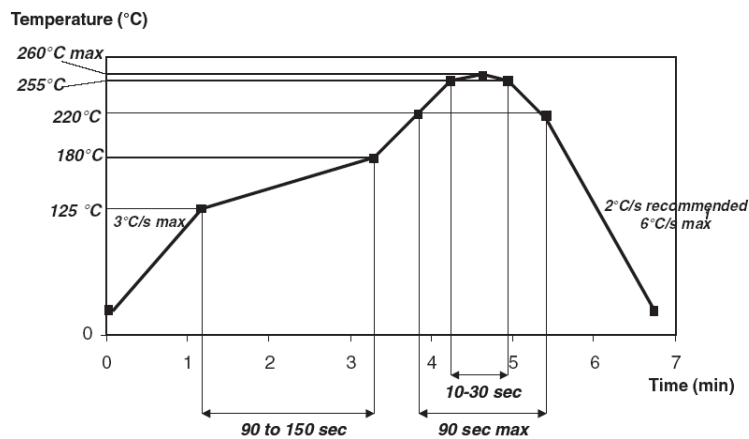

GADG041120210925SA

This profile is given as a start point only and must be adjusted depending on the PCB size and thickness, overall weight, position of surrounding packages or as well as on the reflow oven specification.

The following precautions must be considered:

- Always preheat the device. The purpose of this step is to minimize the rate of temperature rise to less than 3 °C/s to minimize the thermal shock on the components.
- Dry out section, after preheating, to ensure that the solder paste is fully dried before starting the reflow step. This step also allows to even out the temperature gradient on the PCB.
- Peak temperature should be at least 30 °C higher than melting point of the solder alloy to ensure reflow quality. In any case peak temperature should not exceed 260 °C.

## 2.6 Wave soldering

Wave soldering is not recommended for HU3PAK package. As package is surface mount package, wave soldering is not the most-adapted process to solder correctly the whole lead tip surface (if area between lead tip and PCB is not fully soldered, this may impact current flow between lead and PCB).

But the main reason is related to package top side: due to DBC exposed copper, during wave soldering, some Sn wets on the copper surface, which is necessarily generate topology on the package surface, as surface tensions generate much thicker tin layer at the center of the package compared to the edge.

And this topology generates additional thermal resistance between package-top surface and heat sink (it is required to use thicker thermal compound or thermal pad layer).

### 3 Heat sink attachment to package

#### 3.1 Thermal resistance

The thermal resistance of semiconductor assembly is the parameter that characterizes its resistance to the heat flow generated by the junction during operation. A temperature exceeding the maximum junction temperature curtails the electrical performance and may damage the device.

The maximum dissipated power capability is:

$$P_{R_{thJA} \max} = \frac{T_J \max}{R_{thJA} \max}$$

Where:

- $T_J \max$  is the maximum junction temperature of the semiconductor in degrees (°C)  $T_A$  is the ambient air temperature in degrees (°C)
- $R_{thJA}$  is the thermal resistance between junction and ambient air/coolant in °C/W
- The  $R_{thJA}$  takes into account all materials between the junction and ambient air.

Figure 10. Thermal equivalent diagram

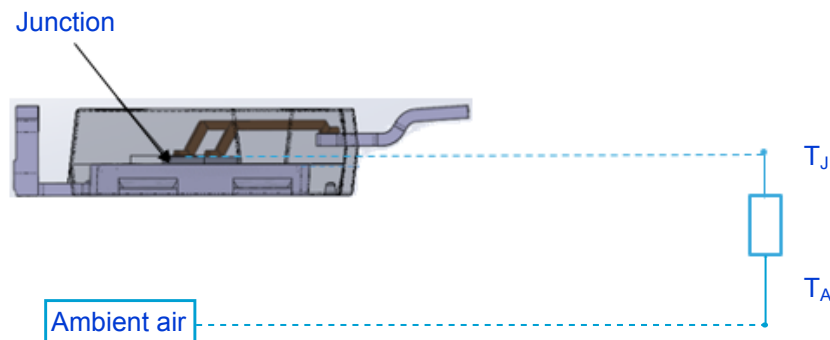

GADG041120210928SA

#### 3.2 Thermal path

The HU3PAK package is designed to have a heat sink pad located on the top of the device, in order to connect to a heat sink.

The HU3PAK package is designed to ensure that the thermal path from the die junction (where the heat is generated) to the thermal pad is kept as highly thermally conductive as possible. The purpose of the heat sink is to keep the thermal path resistance from the device to the ambient environment that receives this heat (whether it is water or atmosphere), also as low as possible.

So, the total resistance from junction to ambient is the sum of:

- The junction to package resistance, defined by package design ( $R_{thJC}$ ).
- The resistance of the thermal pad or compound used between the device and the heat sink ( $R_{thCH}$ )
- The resistance of the heat sink between thermal pad/compound and the ambient environment ( $R_{thHA}$ ).

Figure 11. Thermal equivalent diagram with external heat sink

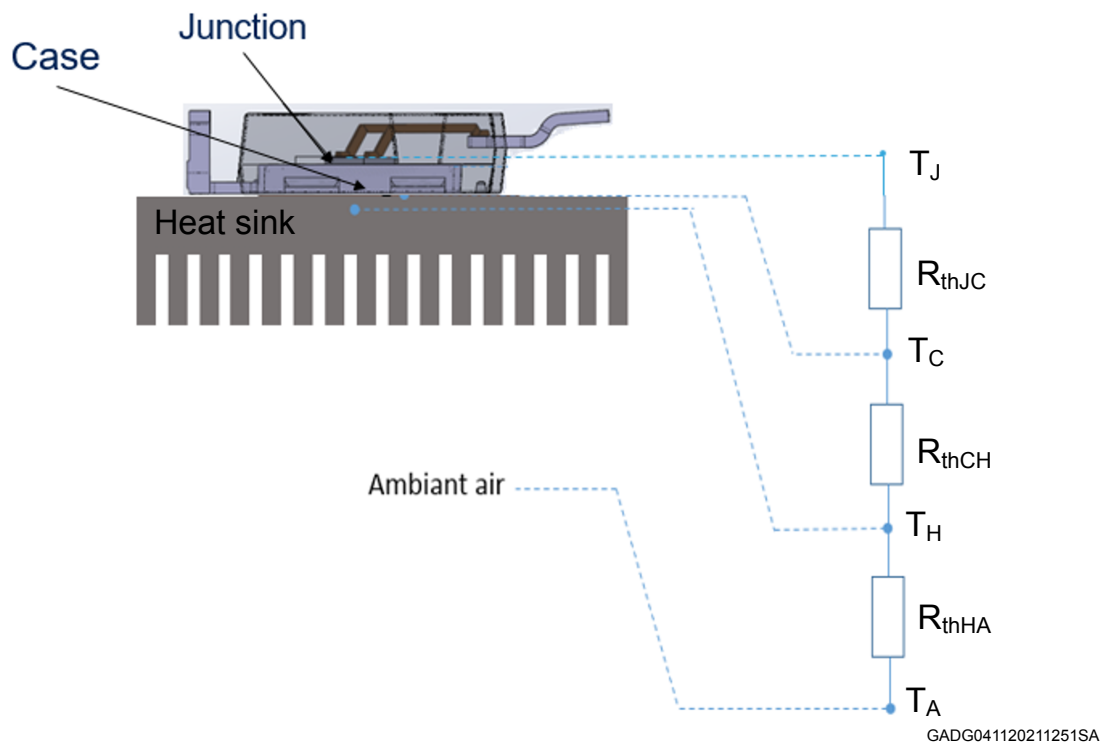

### 3.3 Thermal compound

To lower the thermal resistance of this material, the ideal solution would theoretically be to suppress it completely. The purpose of this thermal compound is to ensure a good contact between the device surface and the heat sink. Also in many cases to provide an electrical insulation between the die/package and the heat sink.

However, to minimize thermal resistance, it is critical to ensure that the two surfaces of the device and the heat sink are in perfect contact. Due to surfaces roughness and flatness imperfections, a thin layer of thermal compound between the two layers to fill the gaps between the two surfaces is required.

The package top side is connected electrically to the drain for MOSFET (to cathode for diodes, anode for thyristors), the thermal compound may only be used in cases where it is possible to have the heat sink connected electrically (one product connected to heat sink for example).

This is usually not recommended, so STMicroelectronics did not evaluate thermal compound for HU3PAK. For other similar cases, STMicroelectronics successfully used HTCP20S from Electrolube.

### 3.4 Thermal pad

In the case where several HU3PAK devices share the same heat sink surface, there is unavoidably some gaps between the packages top surface and the heat sink surface due to differences in heights between the packages and parallelism issues.

These small gaps are significantly increase the contact resistance with the heat sink, and a simple compound may not reliably fill them.

In this case, it may be safer to use soft thermal pads with a thickness sufficient to compensate for the geometrical issues.

The package top side is connected electrically to the drain for MOSFET (to cathode for diodes, anode for thyristors), STMicroelectronics mainly evaluated insulated thermal compounds (to insulate heat sink from the products).

Many thermal compounds are available on the market that may provide good results, STMicroelectronics evaluated successfully silicone based material (reference WGT36 from Fischer Elektronik) and Kapton based material (reference KAP 1 P from Fischer).

### 3.5 Heat sink

Different types of heat sinks provide different  $R_{thJA}$  values, which in turn determines the maximum allowed power dissipation in the dice for a fixed ambient/coolant temperature.

Two main categories of heat sinks may be used:

- Natural convection air cooled heat sinks:** this solution provides the lowest thermal dissipation, but is as well the most simple and cheapest solution. Heat sink is generally a simple extruded aluminum part, attached to the backside of the device. Performance is proportional to the difference between the package temperature and the air temperature used for cooling, and to the area of the exchange surfaces (aluminum to air), so higher heat sink fins, and longer/larger extruded profiles lowers the thermal resistance. It should be noted that care must be taken to allow sufficient room above the heat sink to a sufficient renewal of the ambient air.

Heat sink estimation example:

Given a thermal resistance from junction to device case ( $R_{thJC}$ ) of  $0.7^{\circ}\text{C}/\text{W}$ , if a 50 mm long heat sink of the below type is used (reference SK100 50 from Fischer Elektronik), we get from the diagram that a  $2.5^{\circ}\text{C}/\text{W}$  resistance is to be expected from case to ambient air ( $R_{thCA}$ ), so a total of  $3.2^{\circ}\text{C}/\text{W}$  from junction to air.

If we consider a maximum junction temperature of  $120^{\circ}\text{C}$  and an air temperature of  $40^{\circ}\text{C}$ , this allows a maximum dissipation of  $(T_J - T_A)/R = 80/3.2 = 25\text{ W}$  (without considering the thermal pad).

Figure 12. Passive heat sink Fischer Elektronik SK100 50 datasheet

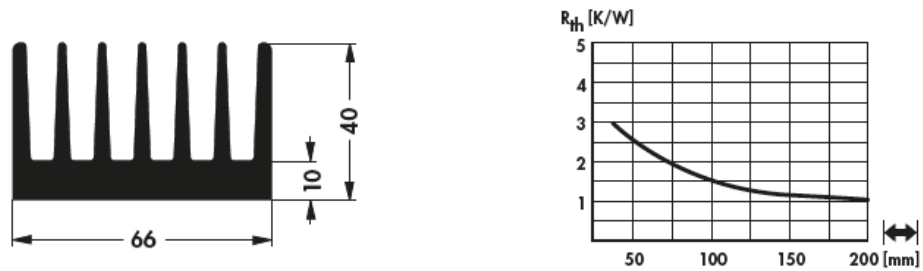

GADG041120211030SA

- Forced air convection:** forcing air flow around the above heat sinks drastically improves the heat exchange, up to several times, depending on the air speed. Tubular heat sinks can be used to improve the heat exchange even further as the air flow is guided along a large exchange area.

Using as an example the below heat sink type (reference LAM5 100 24 supplied by Fischer Elektronik), with a length of 100 mm and a 24 V fan, we read a thermal resistance of  $0.4^{\circ}\text{C}/\text{W}$ , giving a maximum theoretical allowed dissipation of  $80/1.1=72\text{ W}$  in the same conditions.

Figure 13. Forced convection heat sink Fischer Elektronik LAM5 100 datasheet

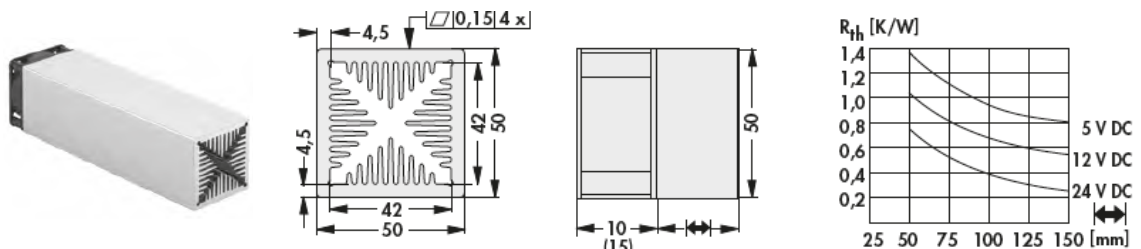

GADG041120211123SA

These heat sink designs are examples, of course many other designs may be available. Customers may for sure also use different heat sinks like liquid cooled heat sinks, which may provide significantly better thermal performances.

### 3.6 Heat sink attachment

The easiest way to attach the device mounted on PCB is to use screws.

M4 screws, located on a 44x24 mm square pattern can be used.

However, this method may generate stress on the PCB and bend it, even with limited torque applied to the screws.

Various parameters may impact stiffness of the PCB (PCB design, material,...), but we suggest applying this mounting condition only if PCB is very thick (above 4 mm).

Figure 14. Example of a simple heat sink attachment

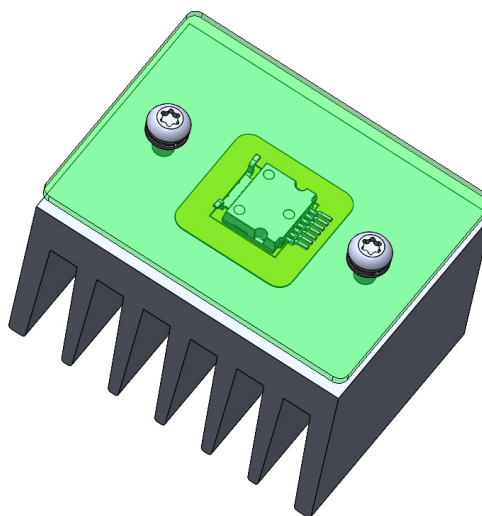

GADG080920210801SA

In order to limit the PCB warpage, a counterplate can be attached on the back of the PCB. Any material can be used, but using metal prevents the presence of tracks below the counterplate.

To ensure no stress is applied on the PCB, the following assembly is recommended: a square hole in the PCB located below the HU3PAK device can contain a spacer slightly thicker than the PCB (for example 2 mm for a 1.6 mm PCB). The counterplate will apply pressure directly on the package backside without pressing on the PCB itself.

Depending on the customer requirements, by using spacer thick enough, such a solution may allow to significantly limit impacted area on the PCB back side, it may allow to place components on the bottom side of the PCB.

Many other ways may be used to ensure robust contact between heat sink and package top side. Stress applied on PCB (and thus solder joints) should be evaluated to ensure that final product reliability is not impacted (cracks in solder joints,...).

Figure 15. Example of heat sink assembly with counterplate

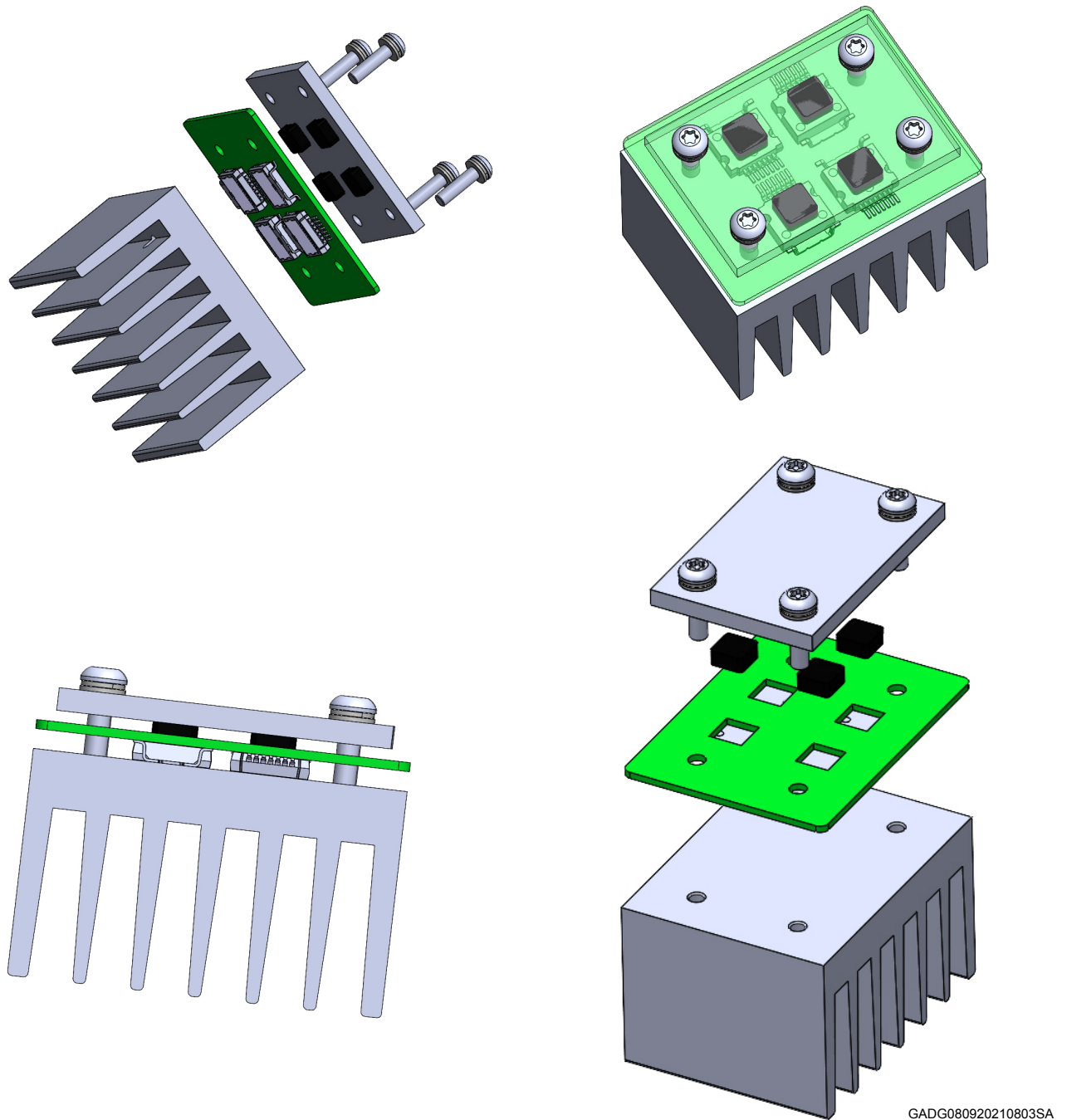

GADG080920210803SA

### 3.7 Assembly reliability

To ensure solder joints reliability of HU3PAK packages soldered on PCB, experiments were performed. The worst cases of PCB deformation were evaluated. A gap of 0.3 mm was forced to reach the worst case of PCB bending. Three cases were studied as shown in the next Table 2. **PCB mounting option.** On the first case, the flexion of the PCB was forced using a short spacer. The tightening of the screw leads to a bending the PCB. The gap is about 0.3 mm. On the second case, the spacer used is too long and a pressure screw presses the package against the heat sink. This assembly forces the PCB to bend downward, and the gap is about 0.3 mm. The third case is a less stressful configuration, where the PCB is assembled with minimal bending.

Table 2. PCB mounting option

Case 1	Case 2	Case 3
<ul style="list-style-type: none"> <li>• PCB is mounted on heat sink using too short spacers.</li> <li>• Tightening screws bends the PCB against the spacers.</li> <li>• Initial gap: approximately 0.3 mm.</li> <li>• Distance between screw and package center: 22 mm.</li> <li>• PCB: 1.6 mm FR4.</li> </ul>	<ul style="list-style-type: none"> <li>• PCB is assembled using spacers too long, stiffener, and pressure screw.</li> <li>• Tightening pressure screw presses the package against the heat sink bending the PCB downward.</li> <li>• Initial gap: approximately 0.3 mm.</li> <li>• Distance between screw and package center: 22 mm.</li> <li>• PCB: 1.6 mm FR4.</li> </ul>	<ul style="list-style-type: none"> <li>• Pure vertical pressure is applied on solder joints using stiffener only.</li> <li>• Distance between screw and package center: 22 mm.</li> <li>• PCB: 1.6 mm FR4.</li> </ul>

Reliability was conducted on the 3 cases from -55 °C up to 150 °C at a frequency of two cycles per hour. The device is submitted to cycled temperature excursions, between a hot and a cold chamber in air atmosphere. No electrical default nor drift were recorded in all the three cases after 3000 cycles.

### 3.8 Screw tightening torque

Over tightening the screws may cause screw damage. It is important to ensure minimum tightening force to ensure good thermal contact, but over tightening screws does not improve thermal resistance beyond a given torque.

The applied torque must overcome the friction of the thread, plus the friction of the head on the bearing surface. The rest is used to lengthen the screw and therefore create force.

The useful torque only represents 10 to 15% of the tightening torque. An error in the friction coefficients can greatly vary the force calculated for a given torque.

The torque is proportional to the force and depends on the head friction, the thread friction and the elongation. It can be calculated using the following formula:

$$C = (p/2\pi + 0.583 d \mu_f + (D/2) \mu_t) \cdot F$$

Where:

- C = couple
- F = force
- p = thread pitch
- d = screw diameter.
- D = average diameter under head = (screw diameter + head diameter) / 2
- $\mu_f$ : thread friction coefficient
- $\mu_t$ : head friction coefficient.

For a cleaned and lubricated thread, the typical coefficients for steel are:

- $\mu_f = 0.1$
- $\mu_t = 0.125$

The application of this formula to a 4 mm screw with a CHC head of 7 mm gives the following formula:

$$F = C / (0.16 \cdot 0.7 + 0.1 \cdot 0.583 \cdot 4 + 0.125 \cdot 5.5/2)$$

$$\text{So, } F = C / 0.69$$

For a screw tightened with a torque at 1 N · m, F=1450N

Depending on screw quality used, screwing torque higher than 1 N · m may be used.

### 3.9 Recommended screws

We recommend screws with regular washer and spring washer.

Screws with coating for thread locking may also be used. Description of M4 screws is presented in figures here below.

We recommend stainless steel for screw material, even if various other materials can be used. It may be also linked to environment and/or application constraints.

Figure 16. Screws design suggestions

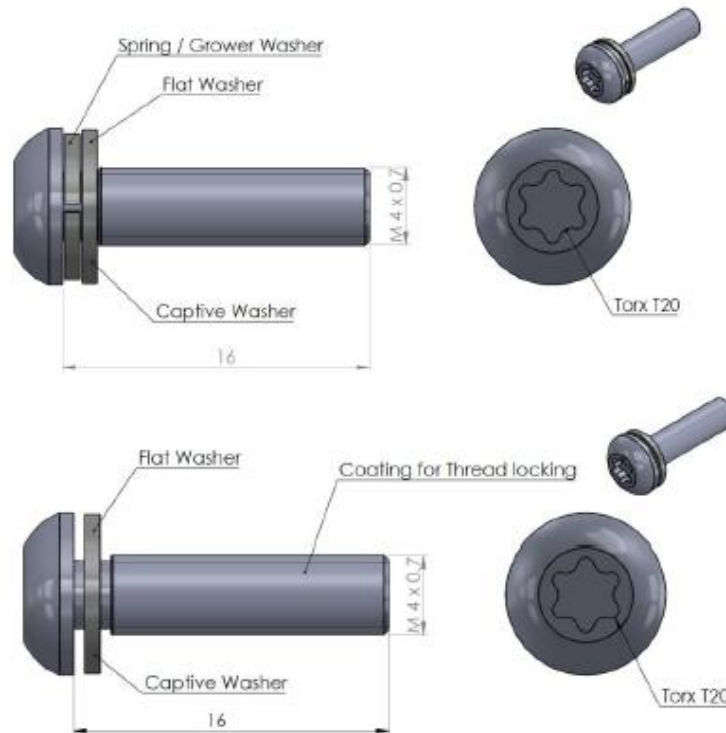

GADG041120211227SA

### 3.10 Creepage distance

In order to protect the user from the effect of operating voltages, a sufficient creepage distance is required. It refers to the smallest distance required between two conductive materials along the surface of an insulator between. The creepage distance is chosen depending on the pollution degree, please refer to the [Table 3. Creepage distances to avoid failure due to tracking](#). The creepage distance measurement varies depending on the assembly configuration and the use of cemented/uncemented insulation foil.

The choice of the insulating foil impacts the creepage distance to be considered. Using an uncemented insulating foil, comes with the risk of imperfect contact and therefore, impacts the creepage distance to be considered. In the following section, we differentiates between two mounting configurations. The first involves using an uncemented foil and the second a cemented foil.



**Table 3. Creepage distances to avoid failure due to tracking**

Voltage	Minimum creepage distances								
	Printed wiring material		Pollution degree						
			1	2			3		
	All material groups (mm)	All material groups, except III (mm)	All material groups (mm)	Material group I (mm)	Material group II (mm)	Material group III (mm)	Material group I (mm)	Material group II (mm)	Material group III (mm)
10	0.025	0.040	0.080	0.400	0.400	0.400	1.000	1.000	1.000
12.5	0.025	0.040	0.090	0.420	0.420	0.420	1.050	1.050	1.050
16	0.025	0.040	0.100	0.450	0.450	0.450	1.100	1.100	1.100
20	0.025	0.040	0.110	0.480	0.480	0.480	1.200	1.200	1.200
25	0.025	0.040	0.125	0.500	0.500	0.500	1.250	1.250	1.250
32	0.025	0.040	0.14	0.53	0.53	0.53	1.30	1.30	1.30
40	0.025	0.040	0.16	0.56	0.80	1.10	1.40	1.60	1.80
50	0.025	0.040	0.18	0.60	0.85	1.20	1.50	1.70	1.90
63	0.040	0.063	0.20	0.63	0.90	1.25	1.60	1.80	2.00
80	0.063	0.100	0.22	0.67	0.95	1.30	1.70	1.90	2.10
100	0.100	0.160	0.25	0.71	1.00	1.40	1.80	2.00	2.20
125	0.160	0.250	0.28	0.75	1.05	1.50	1.90	2.10	2.40
160	0.250	0.400	0.32	0.80	1.10	1.60	2.00	2.20	2.50
200	0.400	0.630	0.42	1.00	1.40	2.00	2.50	2.80	3.20
250	0.560	1,000	0.56	1.25	1.80	2.50	3.20	3.60	4.00
320	0.75	1.60	0.75	1.60	2.20	3.20	4.00	4.50	5.00
400	1.0	2.0	1.0	2.0	2.8	4.0	5.0	5.6	6.3
500	1.3	2.5	1.3	2.5	3.6	5.0	6.3	7.1	8.0 (7.9)
630	1.8	3.2	1.8	3.2	4.5	6.3	8.0 (7.9)	9.0 (8.4)	10.0 (9.0)
800	2.4	4.0	2.4	4.0	5.6	8.0	10.0 (9.0)	11.0 (9.6)	12.5 (10.2)
1000	3.2	5.0	3.2	5.0	7.1	10.0	12.5 (10.2)	14.0 (11.2)	16.0 (12.8)
1250			4.2	6.3	9.0	12.5	16.0 (12.8)	18.0 (14.4)	20,0 (16.0)
1600			5.6	8.0	11.0	16.0	20.0 (16.0)	22.0 (17.6)	25.0 (20.0)
2000			7.5	10.0	14.0	20.0	25.0 (20.0)	28.0 (22.4)	32.0 (25.6)
2500			10.0	12.5	18.0	25.0	32.0 (25.6)	36.0 (28.8)	40.0 (32.0)
3200			12.5	16.0	22.0	32.0	40.0 (32.0)	45.0 (36.0)	50.0 (40.0)

1. **Uncemented insulating foil:**

One of the possible mounting configurations involves an uncemented insulating foil. Uncemented insulating foil refers to a non-adhesive thermal interface material.

In case the package is used on an uncemented insulation foil, there is a risk of imperfect contact between the foil and the package. Therefore, the gap can create a pathway between the leads and tab. In this case, the creepage distance to consider is measured from the backside tab to the lead, as shown in the figure below. The minimum distance measured is 3.7 mm.

**Figure 17. Creepage distance in HU3PAK on uncemented insulating foil**

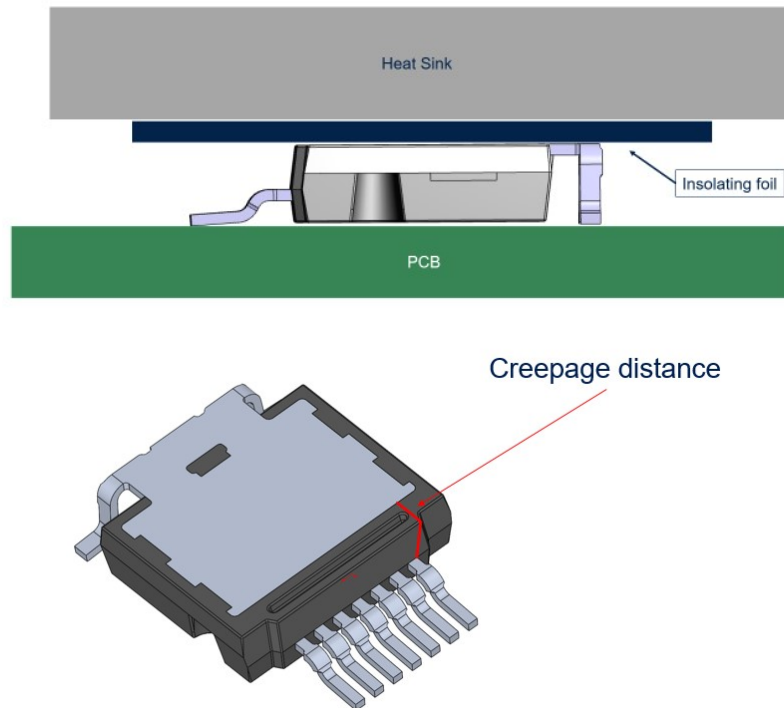

GADG021120211341SA

Depending on the pollution degree and the material group of the resin, the maximum rms voltage that can be withstand by the package is defined in the table below:

**Table 4. Maximum rms voltage capability with a creepage distance of 3.7 mm**

Pollution degree	Material group	Max rms voltage
1	I and II	1070 V
2	II	515 V

2. **Cemented insulating foil:**

Another possible mounting configuration involves a cemented insulating foil.

A cemented insulating foil refers to an adhesive thermal interface material.

In the case of a cemented insulating foil, there is no gap between the package and the foil. Therefore, the creepage distance is the distance between the lead and the heat sink.

Creepage distance =  $t_i + l$

**Figure 18. Creepage distance in HU3PAK on cemented insulating foil**

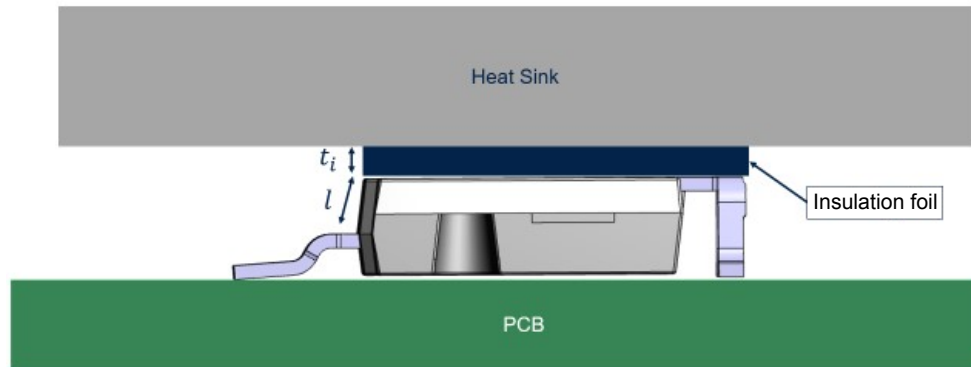

GADG021120211349SA

To increase the creepage distance for an application that requires a higher voltage, the length of the insulating foil can be increased.

**Figure 19. Increase the creepage distance in HU3PAK on cemented insulating foil**

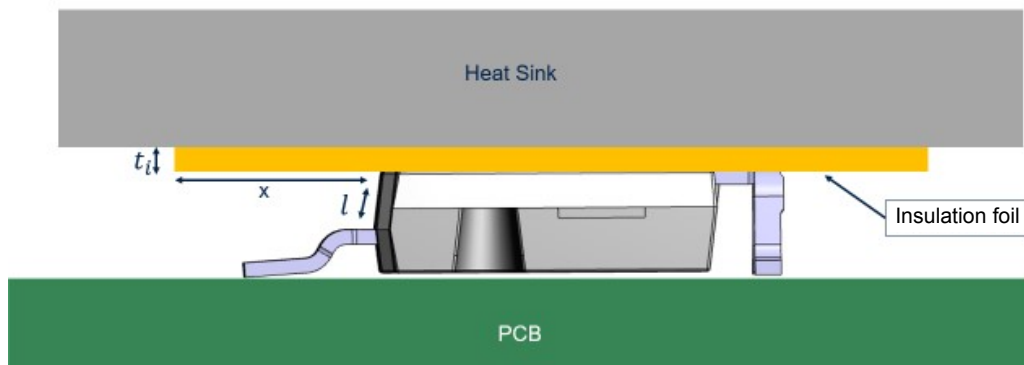

GADG021120211351SA

Example: for a resin material from group II and a pollution degree II. If we consider an application that requires 850 V as a max rms voltage. Based on the norm IEC 60664-1:2020, the minimum creepage distance to avoid failure due to tracking is 6.02 mm. The minimum distance  $x$  that can be used is:  $x = 6.02 - (t_i + l)$

In the case where the insulating foil thickness  $t_i = 0.1$  mm and with  $l = 1.93$  mm, the minimum length to avoid failure is:  $x = 3.99$  mm. Nevertheless, the measured distance between the lead and the notch is 6.4 mm. In case the calculated distance is higher than the distance lead to notch ( $t_i + l + x > 6.47$  mm), then the creepage distance is 6.47 mm, as in the scheme below:

Figure 20. Distance “lead to notch” in HU3PAK

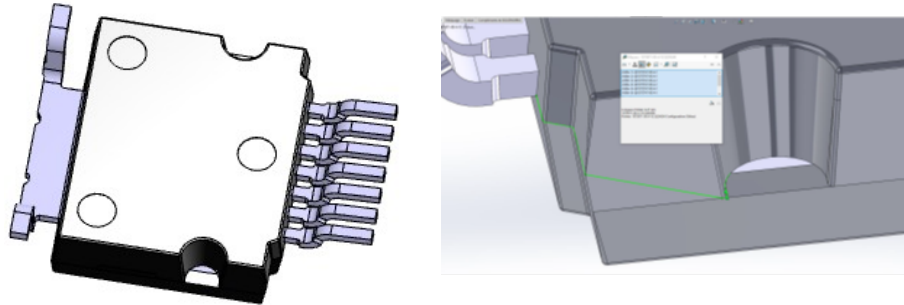

GADG080920210908SA

In this case, based on pollution degree and material group of the resin, the maximum acceptable voltage is defined by the table below:

Table 5. Maximum rms voltage capability with a creepage distance of 6.47 mm

Pollution degree	Material group	Max rms voltage
1	I and II	1750 V
2	II	910 V

## 4 Conclusion

---

Various information and recommendations were provided on how to use an HU3PAK package. For more thermally demanding applications, even if not thoroughly described in this technical note, forced convection heat sinks may be used (or depending on customer applications, more efficient heat sinks like liquid cooling heat sinks may be used).

## Revision history

**Table 6. Document revision history**

Date	Revision	Changes
19-Nov-2021	1	First release.

## Contents

<b>1</b>	<b>Package information</b>	<b>2</b>
1.1	Package dimensions and packing	2
1.2	Moisture sensitivity	4
1.3	Component solderability	4
<b>2</b>	<b>Printed circuit board assembly</b>	<b>5</b>
2.1	Printed circuit board recommendations	5
2.1.1	Material	5
2.1.2	Copper	5
2.1.3	PCB pad design	5
2.1.4	PCB solderable metallization	6
2.1.5	Footprint	6
2.2	Screen printing stencil	7
2.3	Solder paste	8
2.4	Placement	8
2.5	Reflow profile	9
2.6	Wave soldering	9
<b>3</b>	<b>Heat sink attachment to package</b>	<b>10</b>
3.1	Thermal resistance	10
3.2	Thermal path	10
3.3	Thermal compound	11
3.4	Thermal pad	11
3.5	Heat sink	12
3.6	Heat sink attachment	13
3.7	Assembly reliability	14
3.8	Screw tightening torque	15
3.9	Recommended screws	16
3.10	Creepage distance	16
<b>4</b>	<b>Conclusion</b>	<b>21</b>
	<b>Revision history</b>	<b>22</b>

List of tables .....25

List of figures.....26



## List of tables

<b>Table 1.</b>	HU3PAK package mechanical data . . . . .	3
<b>Table 2.</b>	PCB mounting option . . . . .	15
<b>Table 3.</b>	Creepage distances to avoid failure due to tracking . . . . .	17
<b>Table 4.</b>	Maximum rms voltage capability with a creepage distance of 3.7 mm . . . . .	18
<b>Table 5.</b>	Maximum rms voltage capability with a creepage distance of 6.47 mm . . . . .	20
<b>Table 6.</b>	Document revision history . . . . .	22

## List of figures

Figure 1.	HU3PAK package overview . . . . .	1
Figure 2.	HU3PAK package outline . . . . .	2
Figure 3.	HU3PAK in carrier tape . . . . .	4
Figure 4.	Moisture sensitivity levels. . . . .	4
Figure 5.	Solder mask design. . . . .	5
Figure 6.	HU3PAK recommended footprint (dimensions in mm) . . . . .	7
Figure 7.	HU3PAK sample mounted on test PCB . . . . .	7
Figure 8.	Stencil opening recommendation . . . . .	8
Figure 9.	Recommended soldering reflow profile . . . . .	9
Figure 10.	Thermal equivalent diagram . . . . .	10
Figure 11.	Thermal equivalent diagram with external heat sink. . . . .	11
Figure 12.	Passive heat sink Fischer Elektronik SK100 50 datasheet . . . . .	12
Figure 13.	Forced convection heat sink Fischer Elektronik LAM5 100 datasheet. . . . .	12
Figure 14.	Example of a simple heat sink attachment . . . . .	13
Figure 15.	Example of heat sink assembly with counterplate . . . . .	14
Figure 16.	Screws design suggestions . . . . .	16
Figure 17.	Creepage distance in HU3PAK on uncemented insulating foil . . . . .	18
Figure 18.	Creepage distance in HU3PAK on cemented insulating foil. . . . .	19
Figure 19.	Increase the creepage distance in HU3PAK on cemented insulating foil. . . . .	19
Figure 20.	Distance “lead to notch” in HU3PAK . . . . .	20

**IMPORTANT NOTICE – PLEASE READ CAREFULLY**

STMicroelectronics NV and its subsidiaries (“ST”) reserve the right to make changes, corrections, enhancements, modifications, and improvements to ST products and/or to this document at any time without notice. Purchasers should obtain the latest relevant information on ST products before placing orders. ST products are sold pursuant to ST’s terms and conditions of sale in place at the time of order acknowledgement.

Purchasers are solely responsible for the choice, selection, and use of ST products and ST assumes no liability for application assistance or the design of Purchasers’ products.

No license, express or implied, to any intellectual property right is granted by ST herein.

Resale of ST products with provisions different from the information set forth herein shall void any warranty granted by ST for such product.

ST and the ST logo are trademarks of ST. For additional information about ST trademarks, please refer to [www.st.com/trademarks](http://www.st.com/trademarks). All other product or service names are the property of their respective owners.

Information in this document supersedes and replaces information previously supplied in any prior versions of this document.

© 2021 STMicroelectronics – All rights reserved