

---

## Learning to use the TSC1641

### Introduction

This application note gives the basic information to start using the [TSC1641](#) on an MIPI I3C™ bus and an I<sup>2</sup>C bus.

The [TSC1641](#) is a high precision current, voltage, power, and temperature monitoring analog front-end (AFE).

It monitors current in a shunt resistor and load voltage up to 60 V in a synchronized way. The current measurement can be high-side, low-side, and bidirectional.

The device integrates a high precision 16-bit dual channel analog-to-digital converters (ADC) with a programmable conversion time from 128  $\mu$ s to 32.7 ms.

Moreover, the [TSC1641](#) allows the assertion of several alerts on the voltage, current, power, and temperature signals. Additionally, for best performance, the device's parameters and thresholds can be correctly set using the specific registers. This document describes how to use the alerts to obtain the desired results.

## 1 Glossary and acronyms

---

I3C: MIPI improved inter-integrated circuit interface

I<sup>2</sup>C: inter-integrated circuit

Two-wire communication protocol for connecting multiple devices, allowing data exchange and control within electronic systems.

SCL: clock line

SDA: data line

IBI: in-band interrupt

An in-band interrupt is an interruption triggered by a target. The target pulls the SDA line to the low to ask the controller to communicate.

The controller can then either proceed to a NACK or launch a clock pattern to give the target the possibility to talk.

CCC: common command code

The basic specification of the I3C bus, written by the MIPI alliance, describes the set of available CCCs.

Each CCC asks or writes specific information to a device or devices.

NACK: NACK stands for "not acknowledged" in I<sup>2</sup>C communication. It is a response from the target device indicating that it has not acknowledged the data sent to it by the controller device.

## 2 Analog side

The TSC1641 measures the voltage and the current using two different delta-sigma ADCs.

### 2.1 Current measurement

The current measurement is taken by measuring the voltage through a shunt resistor.

**Figure 1. Schematic of the current measurement through a shunt resistor**



As the current is calculated using Ohm's law, the shunt resistor value must be precisely known. The user must choose a shunt resistor with a resistance value that produces a voltage drop that is within the range of the instrumentation amplifier or ADC being used for measurement. The voltage drop across the shunt resistor should be large enough to provide a measurable signal, and the measurement must be in the range of  $\pm 81.92$  mV.

For example, if the maximum current to measure is 20 A:

$$\frac{81.92mV}{20A} = 4.096 m\Omega \quad (1)$$

For the best performance, STMicroelectronics suggests connecting the shunt resistor through a kelvin connection. The user should consider the shunt resistor heating and choose the shunt resistor value and size that is high enough to avoid excessive heating of the resistor.

As the device can monitor either in high-side or in low-side, VLOAD can be connected to IN+ or IN-.

### 2.2 Voltage measurement

The TSC1641 has a dedicated 16-bit sigma-delta ADC to measure voltage up to 60 V.

The voltage to be monitored can be directly connected to the VLOAD pin.

### 2.3 Power monitoring

The power is calculated by the TSC1641 using the formula:

$$Power = Vload * Current \quad (2)$$

The current is calculated using the formula:

$$Current = \frac{Vshunt}{Rshunt} \quad (3)$$

The Rshunt value is entered by writing in the Rshunt register as explained here.

*Note: The power monitoring works only when VLOAD > 0 V. If VLOAD < 0 V, the power computation is false.*

## 3 Common configuration in I<sup>2</sup>C and I3C

### 3.1 After powerup or after receiving a dynamic address in I3C

TSC1641 has several registers.

**Table 1. TSC1641 map register**

Pointer address (hex)	Register name	Type	Default value	Reset after POR	Reset after shutdown mode	Reset after idle mode	Reset after RST
00h	Configuration register	R/W	0037h	yes	no	no	yes
01h	Shunt voltage register	R	0000h	yes	no	no	yes
02h	Load voltage register	R	0000h	yes	no	no	yes
03h	DC power register	R	0000h	yes	no	no	yes
04h	Current register	R	0000h	yes	no	no	yes
05h	Temperature register	R	8000h	yes	no	no	yes
06h	Mask register	R/W	0000h	yes	no	no	yes
07h	Flags register	R	0000h	yes	no	no	yes
08h	Rshunt register	R/W	0000h	yes	no	no	no
09h	SOL alert limit register	R/W	0000h	yes	no	no	no
0Ah	SUL alert limit register	R/W	0000h	yes	no	no	no
0Bh	LOL alert limit register	R/W	0000h	yes	no	no	no
0Ch	LUL alert limit register	R/W	0000h	yes	no	no	no
0Dh	POL alert limit register	R/W	0000h	yes	no	no	no
0Eh	TOL alert limit register	R/W	0000h	yes	no	no	no
FEh	Manufacturing ID	R	0006h	yes	no	no	no
FFh	Die ID register	R	1000h	yes	no	no	no

Some of these are used to configure the TSC1641.

### 3.2 Configuration register (00h)

#### Default configuration

The TSC1641 is configurable using a configuration register.

**Table 2. Configuration register**

Bit n°	15	14	13	12	11	10	9	8	7	6	5	4	3	2	1	0
name	RST								CT3	CT2	CT1	CT0	TEMP	M2	M1	M0
POR value	0	0	0	0	0	0	0	0	0	0	1	1	0	1	1	1

The TSC1641 configuration register (00h) value is by default 0x0037. It takes voltage or  $V_{SHUNT}$  measurements with a conversion time of 1024  $\mu$ s.

By default, the temperature measurement is not activated.

The TEMP bit in the configuration register must be set to 1 to enable the temperature sensor.

#### Conversion time and available modes of TSC1641

The TSC1641 can be used in several modes:

**Table 3. Table describing available modes**

M2	M1	M0	Mode	Content of read registers
0	0	0	0h: shutdown (low power mode). In this mode, no measurement can be taken, and the device is in low current consumption. The communication interface is active to answer a signal on the bus. <a href="#">Table 6</a> summarizes the register's status. Timeout is not possible in this mode.  This mode is suitable for the I <sup>2</sup> C/SMBus or MIPI I3C interface.	Last acquired value in register 01h to 05h, and 07h.  Register 07h is not cleared.
0	0	1	1h: shunt voltage, triggered, single shot. In this mode, the shunt voltage allows to deliver the current if the Rshunt register has been filled, otherwise the current register remains at 0. After the measurement, the CVRF (conversion ready flag) is set, and data can be read on the shunt voltage register. The ALERT/DRDY pin can also be asserted if the mask register has been programmed properly (CVNR=1). At this stage, the power is not updated.	New acquired value in register 01h, 04h to 07h.  '0' in register 02h and 03h.
0	1	0	2h: load voltage, triggered, single shot. Once the measurement is taken, the CVRF (conversion ready flag) is set, and the data can be read on the load voltage register. The ALERT/DRDY pin can also be asserted if the mask register has been programmed properly (CVNR=1).	New acquired value in register 02h, 05h to 07h.  '0' in register 01h, 03h to 04h.
0	1	1	3h: shunt and load voltage, triggered, single shot. In this mode, shunt and load voltage measurements are taken simultaneously, and power is calculated if the Rshunt register has been filled. After the measurement is taken, the CVRF (conversion ready flag) is set, and the data can be read on the shunt voltage register. The ALERT/DRDY pin can also be asserted if the mask register has been programmed properly (CVNR=1).	New acquired value in register 01h to 07h.
1	0	0	4h: idle mode. No measurement can be taken in this mode. Bus communication is active, and timeout can be detected. The device can be activated in a very short time. <a href="#">Table 6</a> summarizes the register's status.  This mode is suitable for the I <sup>2</sup> C/SMBus or MIPI I3C interface.	Last acquired value in register 01h to 07h.  Register 07h is cleared after a read.
1	0	1	5h: continuous shunt voltage. Shunt voltage measurement is taken in a continuous way in the conversion time that is defined in the configuration register with the bits CT3-CT0. After the shunt voltage measurement is taken, if the Rshunt register has been filled, the current register is computed. The conversion ready information is available similarly to the triggered mode.	New acquired value in register 01h, 04h to 07h.  '0' in register 02h and 03h.
1	1	0	6h: continuous load voltage. Load voltage measurement is taken in a continuous way at the conversion time that is defined in the configuration register with the bits CT3-CT0. After the load voltage measurement is gauged, if the Rshunt register has been filled, the power register is computed. The conversion ready information is available similarly to the triggered mode.	New acquired value in register 02h, 05h to 07h.  '0' in register 01h, 03h to 04h.
1	1	1	7h: shunt and load voltage, continuous mode (default).  In this mode, shunt and load voltages are measured simultaneously at the conversion time defined in the configuration register with the bits CT3-CT0. If the Rshunt register has been filled, the power computation is then delivered.	New acquired value in register 01h to 07h.

These modes are selected by writing in the M2-M1-M0 bits of the configuration register.

#### Conversion times

The TSC1641 has a conversion time that varies between 128  $\mu$ s and 32 ms according to the user's needs.

**Table 4. Conversion times available**

CT3	CT2	CT1	CT0	Conversion time
0	0	0	0	128 μs
0	0	0	1	256 μs
0	0	1	0	512 μs
0	0	1	1	1024 μs (default)
0	1	0	0	2048 μs
0	1	0	1	4096 μs
0	1	1	0	8192 μs
0	1	1	1	16384 μs
1	0	0	0	32768 μs
1	x	x	x	Not to be used

By default, the TSC1641 is in continuous mode with a conversion time of 1024 μs. It measures load voltage and shunt voltage. The temperature monitoring is not activated.

#### Examples

##### Example 1:

Fill the configuration register with 0x001F.

1: to set the conversion time to 256 μs.

F: to enable temperature measurement and to stay in shunt and load voltage, continuous mode.

In this example, now the TSC1641 takes a new measurement (voltage, current, etc.) every 256 μs.

Conversion time for temperature is 8.192 ms.

##### Example 2:

Fill the configuration register with 0x0033.

3: to set the conversion time to 1.024 ms (no impact in single mode).

3: to enter in shunt and load voltage, triggered, single shot.

In this mode, a new measurement is taken every time something is written in the configuration register (00h).

Measurement is stored in the read only registers (01h to 04h).

### 3.3 Rshunt register (08h)

The TSC1641 can compute the power directly. To do that, the user must enter the shunt resistor value it uses in its application in the Rshunt register.

The value is encoded in a 16-bit format, with an LSB of 10 μΩ. Therefore, the values entered could be from 0 Ω to 655.35 mΩ.

For example, using a 5 mΩ resistor the formula is the following:

$$\frac{5 \text{ m}\Omega}{\text{Rshunt\_LSB}} = \frac{5 \text{ m}\Omega}{10 \text{ }\mu\Omega} = 500 = 0x01F4 \quad (4)$$

Hence, the value to enter in the Rshunt register (08h) is 0x01F4.

## 4 Alert/data ready function

The TSC1641 has a dedicated pin that can be used either to see if an alert is activated, or as a data ready indicator.

The configuration of the alert/data ready pin is done via the mask register (06h).

**Table 5. Mask register**

Bit n°	15	14	13	12	11	10	9	8	7	6	5	4	3	2	1	0
name	SOL	SUL	LOL	LUL	POL	TOL	CVNR								APOL	ALEN
POR value	0	0	0	0	0	0	0	0	0	0	0	0	0	0	0	0

When the APOL bit is activated, it inverts the polarity of the alert/data ready pin. If this bit is set to 1 the alert/data ready pin is set to 1 when an event is triggered.

The ALEN bit is for alert latch enable. When activated, the alert/data ready pin remains active while the flag register (07h) is not read.

### a: alerts

The TSC1641 embeds six kinds of alerts included in Table 6.

**Table 6. Alerts**

Bit	Alert	Description
15	SOL: shunt over limit	Alert is triggered if $V_{SHUNT} >$ user's threshold
14	SUL: shunt under limit	Alert is triggered if $V_{SHUNT} <$ user's threshold
13	LOL: load over limit	Alert is triggered if $V_{LOAD} >$ user's threshold
12	LUL: load under limit	Alert is triggered if $V_{LOAD} <$ user's threshold
11	POL: power over limit	Alert is triggered if power $>$ user's threshold
10	TOL: temperature over limit	Alert is triggered if temperature $>$ user's threshold

Each alert can be activated in the register 06h shown above by setting the corresponding bit to 1.

Several alerts can be asserted at the same time.

For example, filling 0x2800 in the mask register enables the LOL alert and POL alert.

Each activated alert is triggered only if the associated value crosses the threshold previously set by the user.

These thresholds are located between the 09h and 0Eh register as seen in Table 1.

For example, if the LOL alert threshold is set to 12 V.

The LSB on the voltage channel is 2 mV.

$$\frac{12V}{V_{Load\_LSB}} = \frac{12V}{0.002V} = 6000 = 0x1770 \quad (5)$$

Write 0x1770 in the LOL alert limit register (0Bh).

**Note:** *The alerts on VLOAD (LOL and LUL) and on power (POL) are functional only if  $V_{LOAD} > 0$  V. If  $V_{LOAD} < 0$  V, power and VLOAD alerts could be triggered unintentionally.*

### b: data ready

To enable the data ready function, fill the mask register (06h) with 0x0200.

After a data ready trigger, it informs the user of the end of the sampling and new measurements are available in the read register.

*Note: If the user wants to read the register during the refresh time, which lasts ~ 2  $\mu$ s at the end of each conversion, the TSC1641 NACKs the command. The conversion time is set by the user as previously explained.*

**c: visibility of the alert/data ready**

When an alert or a data-ready trigger occurs, a trigger is sent with:

- An IBI on the I3C bus (except if the IBI is disabled with the DISEC function, then refer to the I3C dedicated application note AN5988).
- The data-ready pin is asserted low if a pull-up is present on the pin ALERT/DRDY. On the other hand, it is asserted to high if the APOL bit has been set to 1.
  - In continuous mode, the pin stays high only during a measurement, which lasts about 2  $\mu$ s. Invert the polarity if the data-ready feature is used, as it reduces the current consumption.
- Reading the flag register (07h) allows the user to know which alert is active.



## 5 I3C typical application

### Hardware configuration

The TSC1641 can communicate on the I<sup>2</sup>C and MIPI I3C bus.

**Figure 2. Typical MIPI I3C hardware configuration**

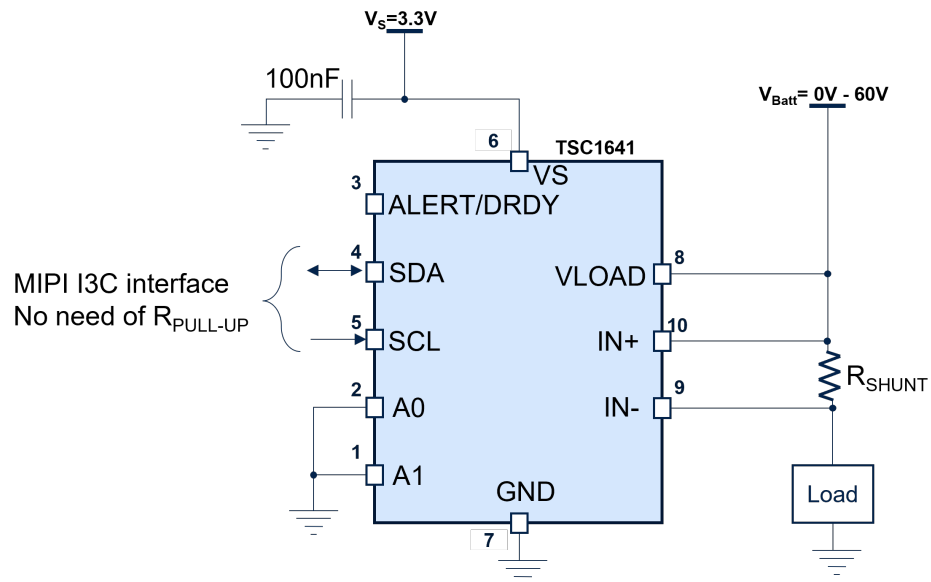

In I3C mode, a pull-up is not needed on SCL and SDA. So, the consumption is lower than in I<sup>2</sup>C mode.

The signal ALERT/DRDY can be replaced by the IBI (in-band interrupt) command for managing the alert and data-ready pin on the I3C bus. However, the ALERT/DRDY pin is still functional.

The TSC1641 has four possible PIDs.

Connect the A1 and A0 pins to choose the PID chip.

**Table 7. Address pins and PID**

A1	A0	Target address (binary)	Target address (h)	Provisional ID (PID) value (h)
GND	GND	1000000	40	0208020A0001
GND	VS	1000001	41	0208020A1001
VS	GND	1000010	42	0208020A2001
VS	VS	1000011	43	0208020A3001

## 6 I<sup>2</sup>C typical application

### Hardware configuration

Figure 3. Typical I<sup>2</sup>C hardware configuration

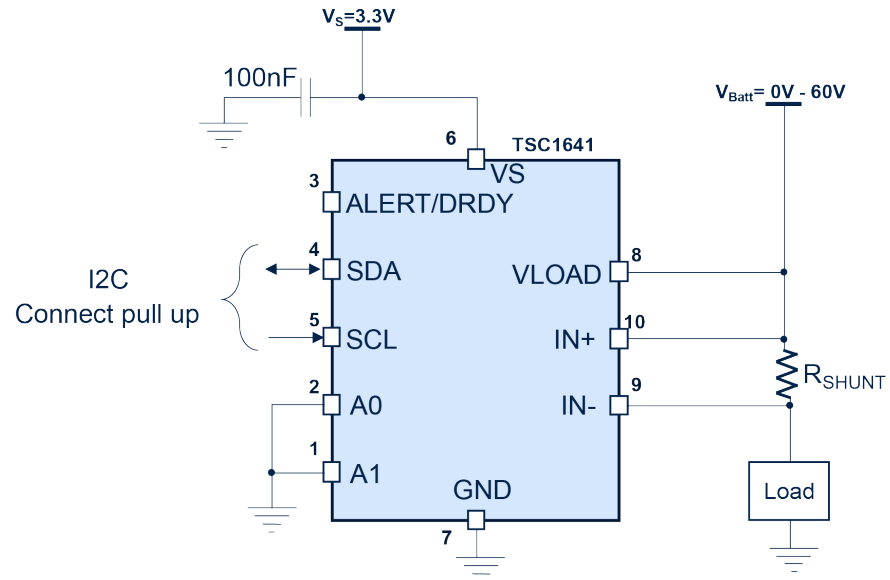

In I<sup>2</sup>C mode, pull-ups are needed on SCL, SDA, and the ALERT/DRDY pin.  
If the ALERT/DRDY pin is not used, it can be left not connected, without a pull-up resistor.

## Revision history

**Table 8. Document revision history**

Date	Version	Changes
17-Nov-2023	1	Initial release.

## Contents

<b>1</b>	<b>Glossary and acronyms</b> .....	<b>2</b>
<b>2</b>	<b>Analog side</b> .....	<b>3</b>
<b>2.1</b>	Current measurement.....	3
<b>2.2</b>	Voltage measurement.....	3
<b>2.3</b>	Power monitoring.....	3
<b>3</b>	<b>Common configuration in I<sup>2</sup>C and I3C</b> .....	<b>4</b>
<b>3.1</b>	After powerup or after receiving a dynamic address in I3C.....	4
<b>3.2</b>	Configuration register (00h).....	4
<b>3.3</b>	Rshunt register (08h).....	6
<b>4</b>	<b>Alert/data ready function</b> .....	<b>7</b>
<b>5</b>	<b>I3C typical application</b> .....	<b>9</b>
<b>6</b>	<b>I<sup>2</sup>C typical application</b> .....	<b>10</b>
	<b>Revision history</b> .....	<b>11</b>

## List of tables

<b>Table 1.</b>	TSC1641 map register . . . . .	4
<b>Table 2.</b>	Configuration register . . . . .	4
<b>Table 3.</b>	Table describing available modes. . . . .	5
<b>Table 4.</b>	Conversion times available . . . . .	6
<b>Table 5.</b>	Mask register . . . . .	7
<b>Table 6.</b>	Alerts . . . . .	7
<b>Table 7.</b>	Address pins and PID. . . . .	9
<b>Table 8.</b>	Document revision history . . . . .	11

## List of figures

<b>Figure 1.</b>	Schematic of the current measurement through a shunt resistor . . . . .	3
<b>Figure 2.</b>	Typical MIPI I3C hardware configuration . . . . .	9
<b>Figure 3.</b>	Typical I <sup>2</sup> C hardware configuration . . . . .	10

**IMPORTANT NOTICE – READ CAREFULLY**

STMicroelectronics NV and its subsidiaries (“ST”) reserve the right to make changes, corrections, enhancements, modifications, and improvements to ST products and/or to this document at any time without notice. Purchasers should obtain the latest relevant information on ST products before placing orders. ST products are sold pursuant to ST’s terms and conditions of sale in place at the time of order acknowledgment.

Purchasers are solely responsible for the choice, selection, and use of ST products and ST assumes no liability for application assistance or the design of purchasers’ products.

No license, express or implied, to any intellectual property right is granted by ST herein.

Resale of ST products with provisions different from the information set forth herein shall void any warranty granted by ST for such product.

ST and the ST logo are trademarks of ST. For additional information about ST trademarks, refer to [www.st.com/trademarks](http://www.st.com/trademarks). All other product or service names are the property of their respective owners.

Information in this document supersedes and replaces information previously supplied in any prior versions of this document.

© 2023 STMicroelectronics – All rights reserved